

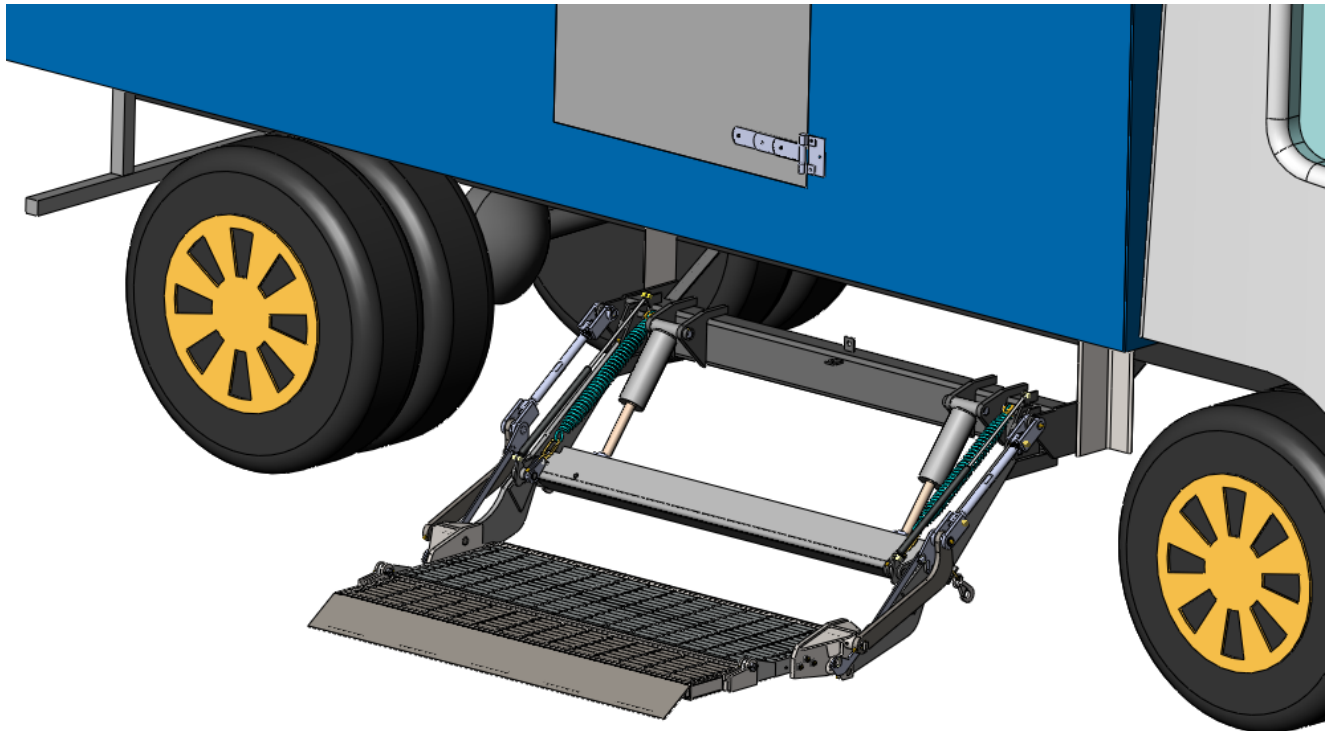

Installation Manual

LTS Hide-A-Way[®] Truck Side Gate



10335 Wayne Avenue • Cincinnati, OH 45215
Ph: 513-891-6210 • Toll-Free: 866-539-6261
Fax: 513-891-4761
www.leymanlift.com • sales@leymanlift.com

TABLE OF CONTENTS

Words of Caution	3
Operating the Lift Gate	4
General View – Truck Mounting	5
Truck Preparation before Mounting Gate	6-8
Mounting Gate to Truck	8-11
Install Power Unit Box and Switches	11-13, 18
Setting Platform Slope, Install Bracing, Install Stop Angle	13-16
Install Over-the-Road Safety Locks	16-17
LTS Wiring Diagram	19
Recommended Hydraulic Oil and Grease	20
Decal Placement	21
Final Inspection	22
Installer Notes	23

WORDS OF CAUTION

1. Before any maintenance is performed on this unit, read and understand this manual completely.
2. Do not stand on or behind the platform when operating gate in the folded position.
3. Make sure the ground is clear under the platform when lowering.
4. Do not stand in front of platform when lowering from vertical position or operating in any manner.
5. Never exceed the rated load capacity of this gate.
6. Do not allow persons to operate the unit unless they have been properly trained to do so.
7. Use only factory authorized parts for replacement.
8. Check the area around the unit for persons before operating the lift gate.
9. This lift gate should operate smoothly and the only noise that should be heard is the power unit. Any audible sounds other than the normal power unit operation sound should be thoroughly inspected and the cause of the noise should be pinpointed and corrected.
10. Do not over load – the maximum rated capacity is based on an evenly distributed load all over the platform's flat surface.
11. Always load as close to the center of the platform and as close to the center of the truck sill as possible.
12. 150 Amp circuit breaker (not supplied) must be installed between the starter solenoid and the battery source.
Order from factory as option #111-Circuit Breaker.

We urge the installation of a safety cut-off switch for all truck mounted lift gates. These are installed in the cab of the vehicle, so the power to the lift gate can be turned on/off.

This manual reflects most changes and updates of materials that are common to this type of lift gate. Some may differ due to individual customer requirements. This manual has been established to reflect the common items.

WARNING: Since this gate has bearings at the main pivot points, (tension and compression arms and platform pivots) any welding on these parts must be grounded directly to the part being welded, or you will damage the cylinder and hoses.

OPERATING THE LIFT GATE

- Before operating the lift, read and understand this decal, urgent warning decal, and the Owner's Manual.
- When pulling out the platform in Step 3, be sure area behind is clear so you can safely step backward. Lifting arms should be fully lowered. Stand to the side when performing Step 4.

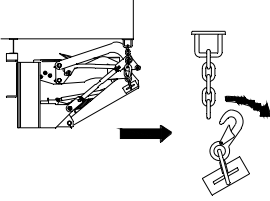
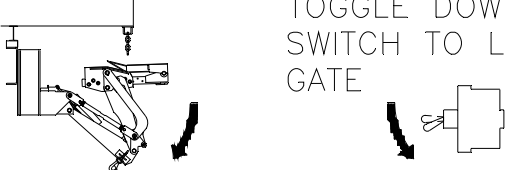
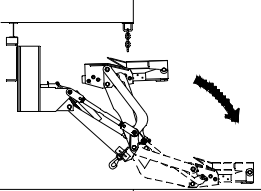
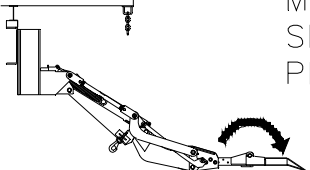
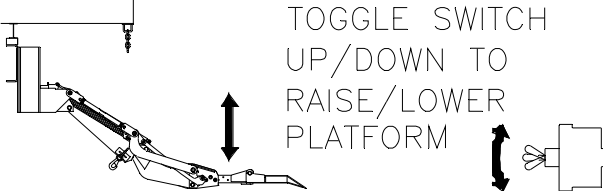
LTS 2000 OPERATING INSTRUCTIONS	
1	 <div style="float: right; padding-left: 20px;"> <p>UNHOOK SAFETY CHAINS</p> </div>
2	 <div style="float: right; padding-left: 20px;"> <p>TOGGLE DOWN SWITCH TO LOWER GATE</p> </div>
3	 <div style="float: right; padding-left: 20px;"> <p>PULL OUT PLATFORM USING HANDLES</p> </div>
4	 <div style="float: right; padding-left: 20px;"> <p>MANUALLY UNFOLD SECONDARY PLATFORM</p> </div>
5	 <div style="float: right; padding-left: 20px;"> <p>TOGGLE SWITCH UP/DOWN TO RAISE/LOWER PLATFORM</p> </div>
6	<p>TO TUCK UNIT UNDER AFTER USE REVERSE STEPS</p> <div style="display: flex; justify-content: center; gap: 10px; margin-top: 10px;"> <div style="border: 1px solid black; padding: 2px 5px;">5</div> <div style="border: 1px solid black; padding: 2px 5px;">4</div> <div style="border: 1px solid black; padding: 2px 5px;">3</div> <div style="border: 1px solid black; padding: 2px 5px;">2</div> <div style="border: 1px solid black; padding: 2px 5px;">1</div> </div>
<p>LEYMAN MANUFACTURING</p> <p>10900 Kenwood Road Cincinnati, OH 45242 513-891-6210 www.leymanlift.com</p> <p style="float: right;">P55427</p>	

GENERAL VIEW – TRUCK MOUNTING LTS GATE – 10 INCH FLOOR THICKNESS

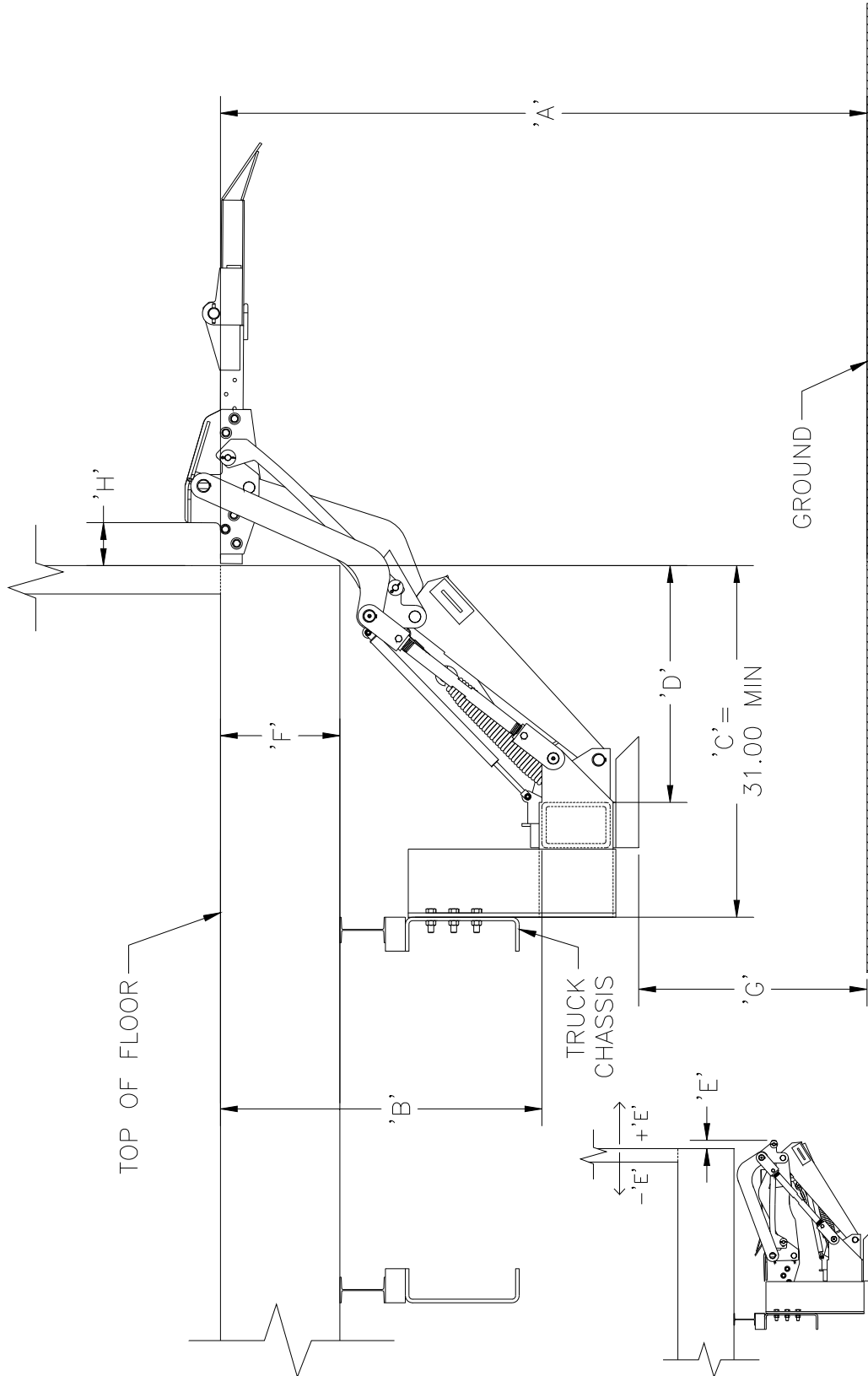

NOTE: OVERALL WIDTH OF GATE INCLUDING LIFTING ARMS IS 75". OVERALL WIDTH OF GATE INCLUDING MOUNTING ANGLES IS 80"

Step 1: TRUCK PREPARATION BEFORE MOUNTING GATE

Mounting Dimensions:

A – Bed to ground height

B – Floor to trunnion distance (vertical)

C – Outside of body to truck frame distance

D – Outside of body to trunnion frame distance (horizontal)

E – Folded protrusion distance

F – Floor thickness

G – Ground clearance

H – Door Clearance

The LTS2000 gate can accommodate both hinged and sliding doors (up to 5 1/4" total thickness). The platform is shipped in the rear set of mounting holes; in this configuration, the gate is capable of a maximum floor thickness of 10 1/2" and a maximum sliding door thickness of 3 1/2". Use Table 1 for trunnion location if you are mounting the gate in this configuration.

If your application requires more than 3 1/2" of clearance for a sliding door, the platform can be moved to the front set of mounting holes. In this configuration, the gate is capable of a maximum floor thickness of 10" and a maximum sliding door thickness of 5 1/4". Use Table 2 for trunnion location if you are mounting the gate in this configuration.

PLATFORM IN REAR HOLES

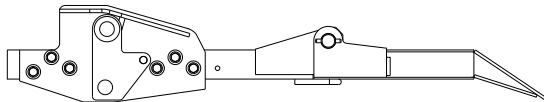

PLATFORM IN FRONT HOLES

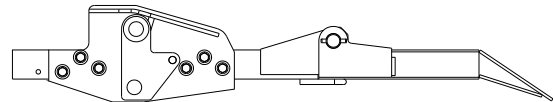

1. Carefully check dimensions defined on page 5. Verify you have the proper space available to mount the gate. Check dimensions (C), (F), and (A) for the vehicle on which you are installing the gate, then refer to Table 1 or Table 2 as required to ensure your dimensions are within the capability of the gate.
 - a) Before proceeding, measure the floor thickness (F) and the bed to ground height (A). Locate the floor thickness row in Table 1 or Table 2 as required.
 - b) Next, find the maximum bed height dimension (A) in the same row next to the floor thickness. If the bed height of your vehicle is greater than that shown for the measured floor thickness, you must use the trunnion mounting dimensions (B) and (D) for your bed height, regardless of the floor thickness. If the bed height is equal to or less than the value shown, use the trunnion mounting dimensions in the same row as the floor thickness.

Moving the trunnion tube up will reduce the folded gate protrusion (E) and increase ground clearance (G). If your floor thickness dimension is larger than 9" with the platform mounted in the rear set of holes (or 8" floor thickness with the platform mounted in the front set of holes), the folded gate will protrude beyond the truck body as indicated in the direction of the +(E) in the figure (a negative

sign in the folded protrusion column indicates the gate does not extend beyond the body, as indicated by a -(E) in the figure).

TABLE 1 – TRUNNION LOCATION VS FLOOR THICKNESS, REAR MTG. HOLES

F Floor Thickness	A Bed Height (Min – Max)	B Floor to Trunnion Distance (vert.)	D Body to Trunnion Distance (horiz.)	G Ground Clearance (@ max bed ht.)	E Folded protrusion distance (ref)	H Door Clearance
10-1/2 (MAX)	51 - 56	29	20-1/8	18-1/2	2	3-1/2
10	50-1/2 - 56	28-1/2	20-3/4	19	1-1/4	3-1/2
9	49 - 56	27-1/2	21-3/4	20	1/4	3-1/2
8 or less	48-1/2 - 55	26-1/2	23	20	-7/16	3-1/2

NOTE:

If the vehicle’s floor thickness (F) is less than 8”, the trunnion will still be located at the 8” floor thickness trunnion mounting dimensions, (B) and (D). This will prevent the gate from protruding beyond the body and prevent a reduction in maximum bed height.

The (B) dimension 29” represents the lowest mounting height from the bed to the top of trunnion tube. For the minimum bed height of 51”, this mounting height will yield 13-1/2” ground clearance (unladed). $[G = 18-1/2”-(56”-51”) = 13-1/2”]$

TABLE 2 – TRUNNION LOCATION VS FLOOR THICKNESS, FRONT MTG. HOLES

F Floor Thickness	A Bed Height (Min – Max)	B Floor to Trunnion Distance (vert.)	D Body to Trunnion Distance (horiz.)	G Ground Clearance (@ max bed ht.)	E Folded protrusion distance (ref)	H Door Clearance
10 (MAX)	48 - 54-1/2	26	21-7/8	19-1/2	2	5-1/4
9	47 - 53-1/2	25	23	20-1/2	7/8	5-1/4
8	46 - 52-1/2	24	24	21-1/2	1/8	5-1/4
7 or less	45 - 51-1/2	23	24-3/4	22-1/2	-5/16	5-1/4

NOTE:

If the vehicle’s floor thickness (F) is less than 7”, the trunnion will still be located at the 7” floor thickness trunnion mounting dimensions, (B) and (D). This will prevent the gate from protruding beyond the body and prevent a reduction in maximum bed height.

The (B) dimension 26” represents the lowest mounting height from the bed to the top of trunnion tube. For the minimum bed height of 48”, this mounting height will yield 13” ground clearance (unladed). $[G = 19-1/2”-(54-1/2”-48”) = 13”]$

2. You will also need adequate space to mount the power unit box (8” x 8” x 22”). This is designed to be located on the curbside of the vehicle to the left of the gate (between the gate and rear wheels). Alternatively, if there is not space in this location, it can be mounted to the frame on the roadside of the vehicle.

3. If the gate is mounted at or near the minimum bed height, the step may need to be moved to the second set of mounting holes to provide adequate clearance while lowering the gate.

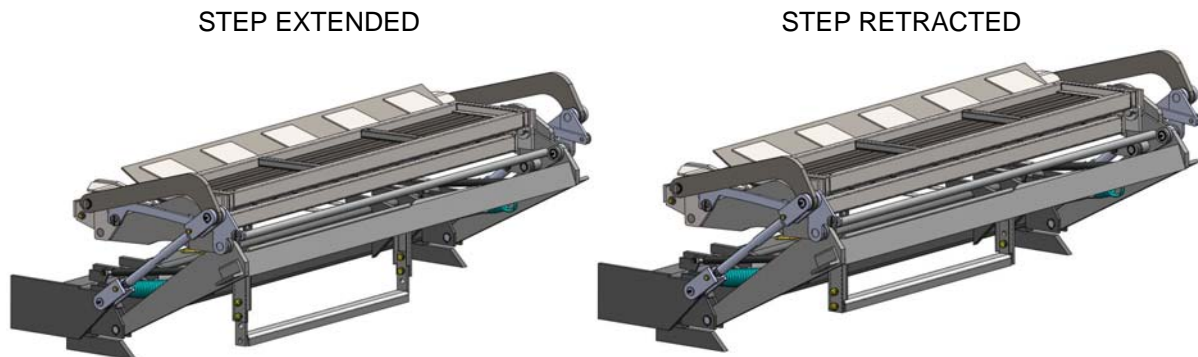

Step 2: MOUNTING GATE TO TRUCK

IMPORTANT!!

Due to the jointed lift arm design of the LTS gate, it does not install the same way as other side mounted lift gates. Please read and thoroughly understand the installation steps before proceeding. Failure to do so may result in increased installation time and/or damage to the gate or its components.

General Installation Overview:

Using a lift truck, the platform will be raised to the vehicle floor height. The dimensions listed in Table 1 and Table 2 are to be used as approximate guidelines for the trunnion location based on your specific application. In order for the trunnion to be moved to a particular set of dimensions, the cylinder rods must be rotated in the cylinder clevis blocks per the instructions in step #5.

With the platform secured at the floor line, if more cylinder rod is exposed (less thread engagement), the trunnion will swing through an upward arc toward the vehicle centerline. If less cylinder rod is exposed (more thread engagement), the trunnion will swing through a downward arc away from the vehicle centerline. In the majority of installations, the trunnion will have to be raised upward by exposing more cylinder rod.

CAUTION! THE MINIMUM THREAD ENGAGEMENT BETWEEN THE CYLINDER ROD AND THE CLEVIS BLOCK IS 1-3/8". DO NOT OPERATE GATE WITH LESS THAN 1-3/8" ENGAGEMENT AS FAILURE COULD OCCUR.

1. Remove banding from gate, verify all parts have been included and inspect for any shipping damage.
2. While still on shipping pallet, unfold the jointed compression arms so that the two halves are touching. **DO NOT PICK UP AT THIS TIME.** Using a discarded piece of metal (plate, angle, etc), weld the two arms together. See Figure 1.

Caution: Place grounding clamp on compression arm before welding.

FIGURE 1 – TEMPORARY JOINING OF COMPRESSION ARMS

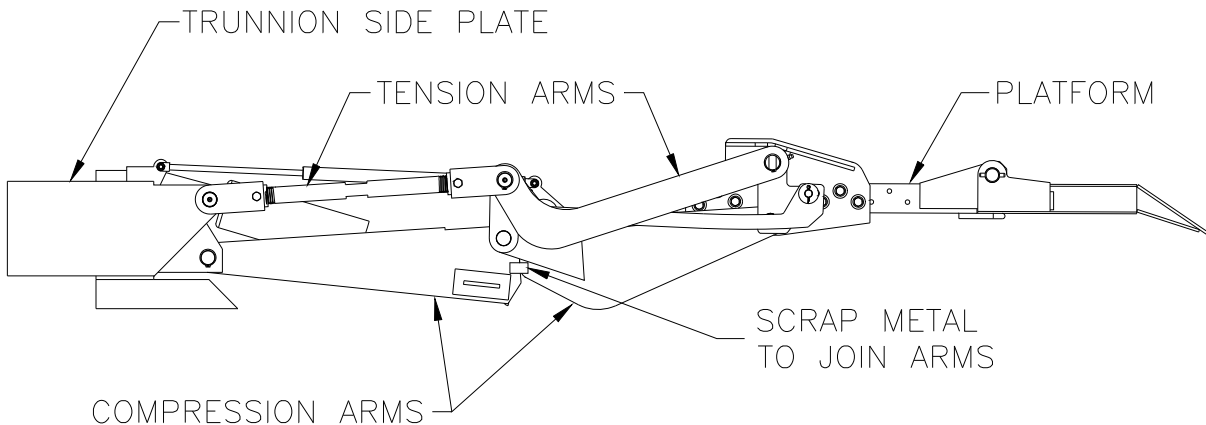

Note: gate is still on shipping pallet - not shown in view for clarity.

3. Unfold the secondary platform/ramp to provide clearance for clamping. Clamp the primary platform to the lift truck. See Figure 2.

IMPORTANT!!

Cylinders must move during installation. To facilitate this and prevent oil leakage, one of the long power unit hoses has been connected between the UP and DOWN cylinder connections on the trunnion tube. If a hose is not in place and the connections on the trunnion tube are capped, remove caps and use one of the 81” hoses supplied to join the cylinder connection ports on the trunnion tube.

4. Place ¼” inch spacers on the side of the truck body, just below door threshold. Raise the gate assembly with the lift truck. Position the platform at the door opening as required and place the rear edge of the platform against the 1/4” spacers. Ensure that the platform is level and even with the threshold. See Figure 2.
5. Next, move the trunnion to the desired location based on your (F) and (A) dimensions. See Table 1 or Table 2 as required for reference. **DO NOT FORCE THE TRUNNION INTO THE DESIRED POSITION. ENSURE THAT THE CYLINDER RODS ARE COMPLETELY RETRACTED.** See pictures below. If the cylinder rods are retracted and the trunnion tube must be moved higher, the cylinder clevises must be adjusted. Loosen the set screws in the cylinder clevises, then turn both cylinder rods equally until more cylinder rod is exposed, or the trunnion raises to its desired position. The fully retracted cylinders will become the “UP STOPS” when the platform is at bed height. Once the trunnion is tack welded in place the cylinder clevises can be readjusted if necessary, so the cylinder rods are completely retracted when the platform is at bed height.



CYL ROD RETRACTED, DO NOT FORCE TRUNNION TUBE LOWER

CYL ROD EXPOSED

6. Locate the two, 6" x 4" x 3/8" x 21" lg. pre-drilled angles in the shipping kit. These angles support the gate from the truck frame (angles are left / right). Position the angles to the outside of the trunnion side plates and clamp in place. Then, mark the holes to be drilled in the truck frame. The bottom of the angle can be cut if there is excessive length below the trunnion side plates, but at least 3/8" must be kept below side plates to place a 1/4" fillet weld. See Figure 2.
7. Drill 9/16" holes through truck frame to attach both mounting plates. Bolt mounting angles in place using supplied hardware. See Figure 2.
8. Next, tack weld the trunnion side plates to the support angles. Welds must be strong enough to support the gate without a load on the platform. Trunnion side plates must overlap the support angles by a minimum of 4" to allow for adequate strength during final welding. If this overlap is not present, spacer plates must be added at the bolted joint between the support angles and the frame rail.
9. Finally, adjust both cylinder rods if necessary so they are completely retracted with the platform positioned at bed height. After adjustments at the clevises are completed, tighten the clevis set screws. The fully retracted cylinder rods are the "UP STOPS" for the platform at bed height.
10. Unclamp the lift truck forks from the platform and lower slowly. The platform will stop about half way down when it meets resistance from the oil in the lift cylinders.

FIGURE 2 – LOCATING AND INSTALLING GATE

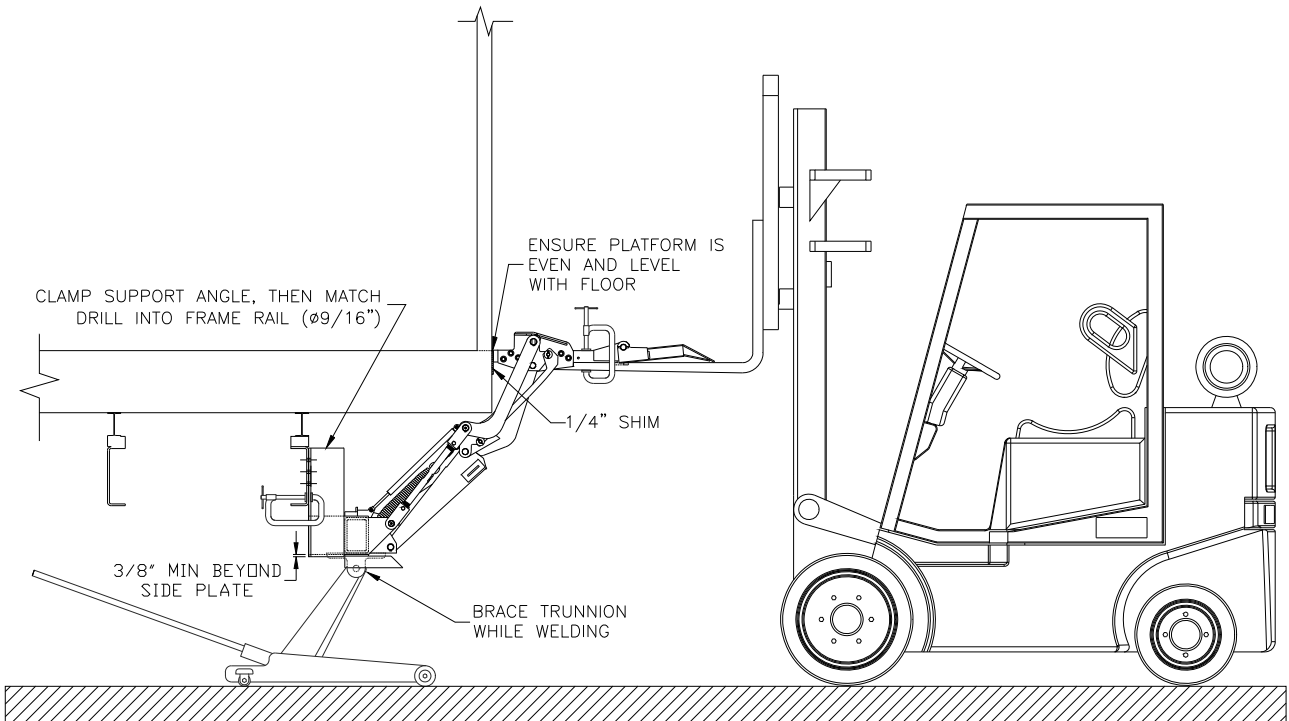

Step 3: INSTALL POWER UNIT BOX AND SWITCHES

1. Determine a location for the power unit box; it can be installed on the curbside of the vehicle behind the gate (between the gate and rear wheels). If there is not enough space to locate the power unit box in this location, it can be mounted on the roadside of the vehicle, directly against the chassis. The power unit brackets can either be welded to the body or bolted to the chassis depending on the final location and your application (hardware not included). Please note that both brackets should be mounted to either the chassis or body, but not one bracket mounted to the body and the other mounted to the chassis. The mounting brackets can be cut to length if they are too long for the application; however, the lid requires a minimum of 4" vertically to swing open. A minimum of 11" is required horizontally for the lid to swing open.

Verify primary hydraulic hoses will connect between the gate and the power unit box. Once the power unit box is mounted, connect the hydraulic hoses to power unit. Be careful to ensure that no dirt or other contaminants have gotten into the hose fittings before connections are made.

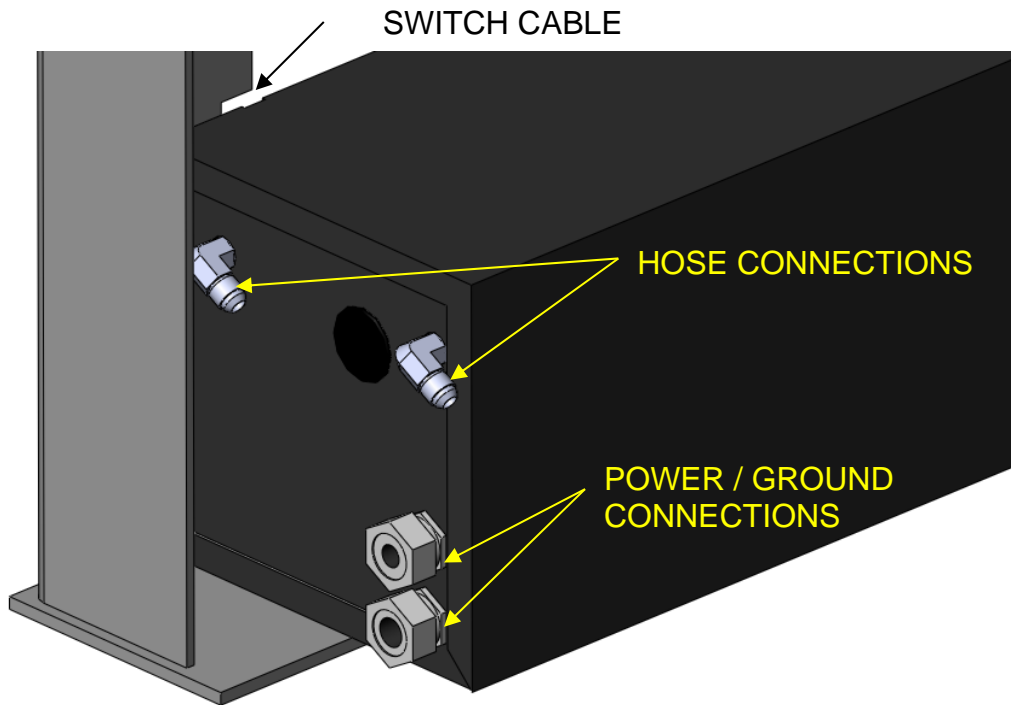

IMPORTANT!!

The hose from the fixed end of the lift cylinder connects to the port labeled “C2” on the power unit. The hose from the rod side of the cylinder connects to the port labeled “C1” on the power unit. If hoses are switched, lift gate will go UP slowly, and not go DOWN.

CONNECT HOSE FROM FIXED
END OF LIFTING CYLINDER TO
PORT “C2”

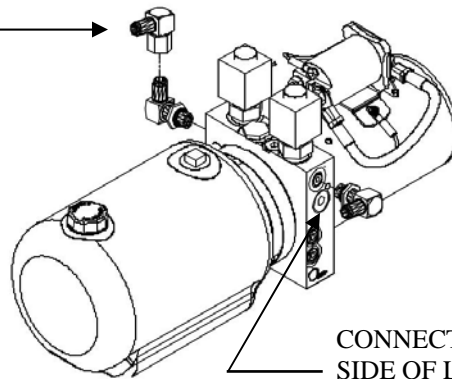

CONNECT HOSE FROM ROD
SIDE OF LIFTING CYLINDER
TO PORT “C1”

2. Run the red 2 gauge power wire (supplied) from the battery to the start solenoid, with a circuit breaker (not supplied) located near battery. Install the black 4 gauge ground cable (supplied) between the ground stud in the box and the truck chassis. Crimp the correct size terminals to each cable and be sure to seal each end using the heat shrink provided. **NOTE! It is extremely important to ground the power unit box to the truck chassis for proper power unit operation.**
3. Install the two UP/DOWN switches in the truck side wall. Use the heat shrink provided at all butt connections. Run the 16-4 cable provided from the power unit box to the lower switch. Route switch cable through the slot at the power unit box door using grommet. Connect the wires at terminal strip inside the power unit box

by matching the wire colors. Cut 16-4 cable to length and butt connect at lower switch. Use the heat shrink provided at all butt connections. See Figure 7.

4. Route 16-4 cable from Lock Valves on the lifting cylinders to the power unit box. This cable enters power unit box through the cord grip near the cover latch. Connect each white wire to the terminal strip in the same position with the other white wires. See Wiring Diagram on page 18. Connect each black wire (ground) to the ground post on the Start Solenoid (small lower post). See Wiring Diagram on page 18.

IMPORTANT!!

Check the power unit tank for oil before operating the gate. See page 19 for recommended hydraulic oils. Fill the tank to within ½” from the top. Check the oil level as you raise and lower the gate to work air out of the system. Refill as required to avoid the pump drawing in air. After operating the gate several times, recheck oil level with the platform at maximum height (at bed level). Oil level should be 1” from top of tank

When lowering the platform watch the oil tank to avoid over-flowing. If over-flowing is about to occur, reverse direction and go up until air is worked out of the system.

5. Run the gate up and down to check its operation. The platform should rise to floor level and lower to ground smoothly. LTS platforms are level ride. Check to see that the slope of the platform is approximately 3/8” higher at the ramp than the rear of the platform to account for deflection under load. If the slope is not at 3/8”, loosen the set screws in the tension arm clevises on both sides of the gate and turn the upper tension arms equally until a 3/8” slope is established. Tighten all four set screws when finished making adjustments. See Figure 3.

FIGURE 3 – SETTING PLATFORM SLOPE

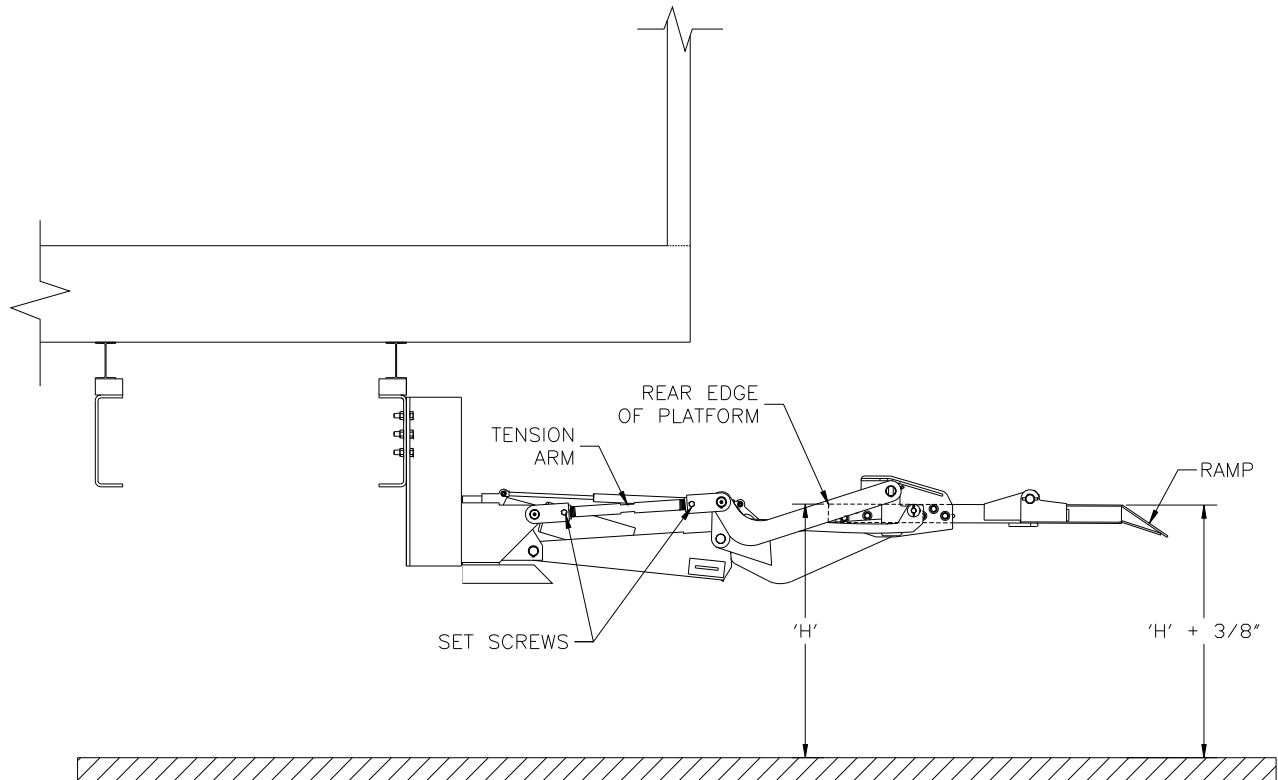

6. Next, verify folding / tucking operation. First, remove welded pieces between the compression arms (from step 2.2). While the platform is resting on or very close to the ground, lift primary platform with the handles to fold gate (if secondary platform is unfolded, flip it over to expose handles on bottom of the primary platform). Raise lifting arms carefully into tucked position

Caution! IN THE FOLDED POSITION, DO NOT RAISE LIFTING ARMS TOO FAR UNTIL THE HYDRAULIC CYLINDERS BOTTOM OUT – YOU WILL PERMANENTLY DAMAGE THE GAS DAMPERS.

Jog the gate up carefully and watch the gas dampers as you are raising the lifting arms to ensure the rods do not completely close. A physical stop will be added later to prevent over travel during normal gate operation.

7. If the gate operation is correct, finish weld the trunnion side plates to the 6" x 4" mounting angles with continuous 1/4" fillet welds. Weld all vertical and horizontal edges. Next, add bracing between the inside of the trunnion side plates and the opposite frame using 3" x 3" x 5/16" angle (not supplied). Ensure there is adequate clearance to allow for drive shaft movement during suspension travel. See Figure 4.

FIGURE 4 – INSTALLING ANGLE BRACING

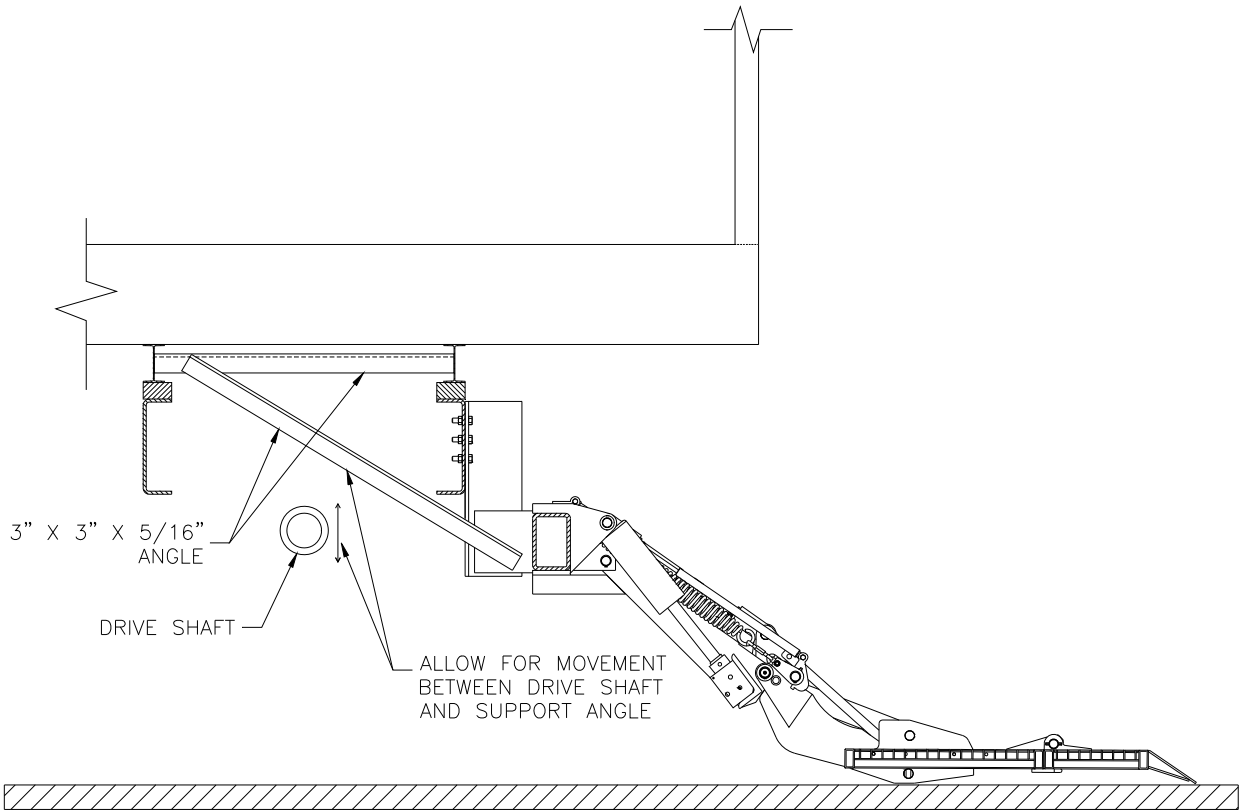

8. If the gate is unfolded, fold it now to install the stop angle between the 6" x 4" mounting angles. Raise the lifting arms carefully; as in the previous step, do not raise the hydraulic cylinders until they bottom out because it will permanently damage the gas dampers. The stop angle is designed to prevent the gate traveling beyond the range of the gas dampers. Position the stop angle so that the top of the angle is 11-1/2" above the top of the trunnion tube and 1/8" back from the rear of the trunnion tube. Adjust the 1/2"-13 HHCS as necessary to prevent the gas damper from over travel, and then lock adjusting bolts in place with jam nuts. See Figure 5.

FIGURE 5 – LOCATING AND INSTALLING STOP ANGLE

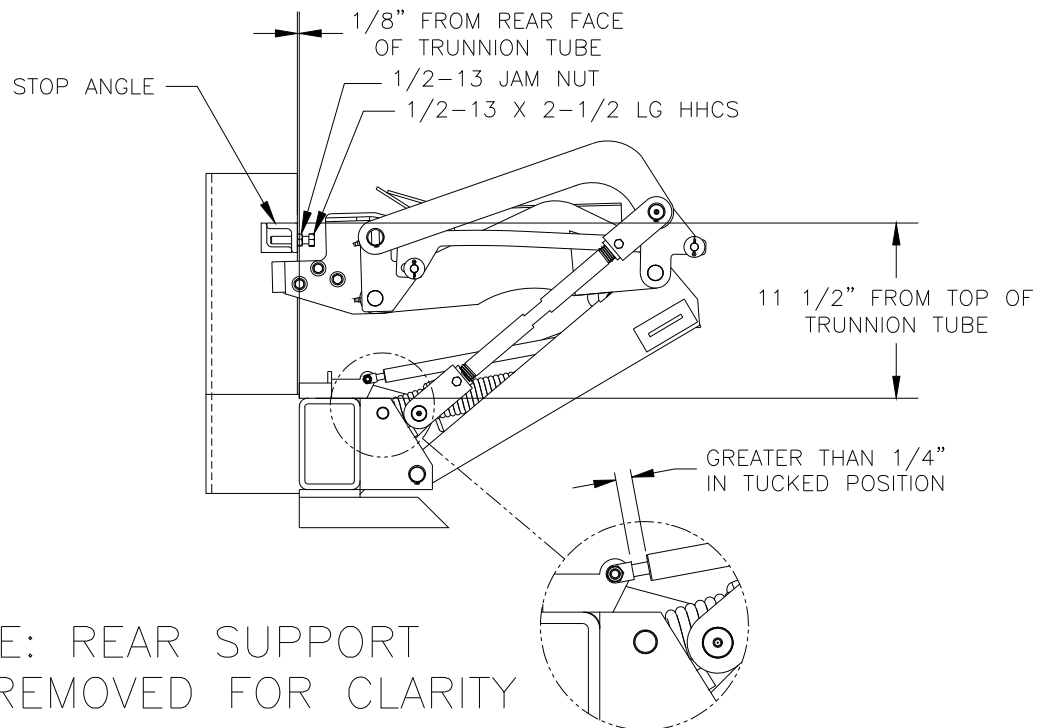

Step 4: INSTALL OVER THE ROAD SAFETY LOCKS

1. Locate the two safety chains with mounting plates in the ship loose parts package. Position the mounting plates on both sides of the gate, toward the outside of the truck body. Ensure the chains are located far enough to the side of the gate so they do not interfere with the folded lifting arms. The mounting plates can be welded, riveted, or bolted to the nearest body floor support at the installer's discretion. If bolting, the holes will need to be enlarged for 1/4" diameter hardware. The safety chains are longer than required to accommodate all installations. With the gate in the transport position, locate the link on the safety chain for the 3/8" quick connect link and snap hook, so that the safety snap hook will easily clip onto the angle bracket (located on the compression arms). However, there should not be excess slack; the chains should become taut if the gate drops 4 inches or less. See Figure 6.1 and 6.2
2. Apply touch up paint to unit where the lifting arms were welded together and any other scratches or chips that may have occurred during installation. Thoroughly clean surfaces and use only the touch up paint that has been provided. Lubricate all grease fittings using the recommended grease. See Recommended Hydraulic Oil and Grease Table on page 19. Apply decals per diagram on page 21

FIGURE 6.1 – SAFETY CHAIN LOCATION, END VIEW

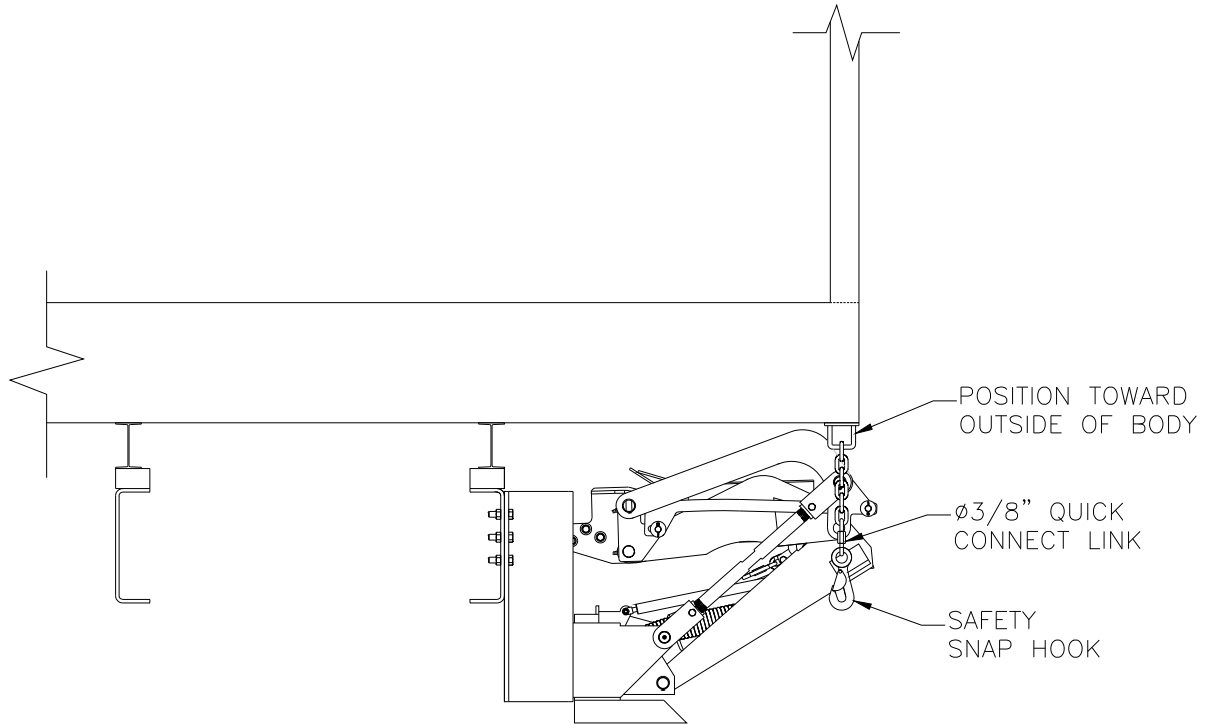

FIGURE 6.2 – SAFETY CHAIN LOCATION, SIDE VIEW

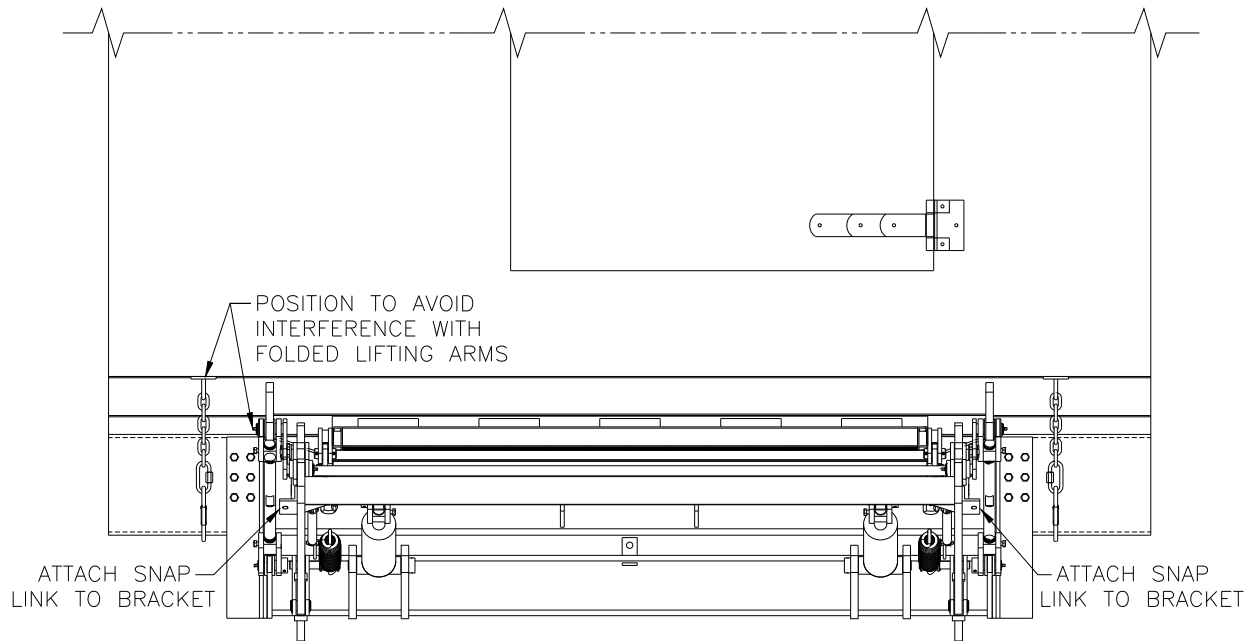
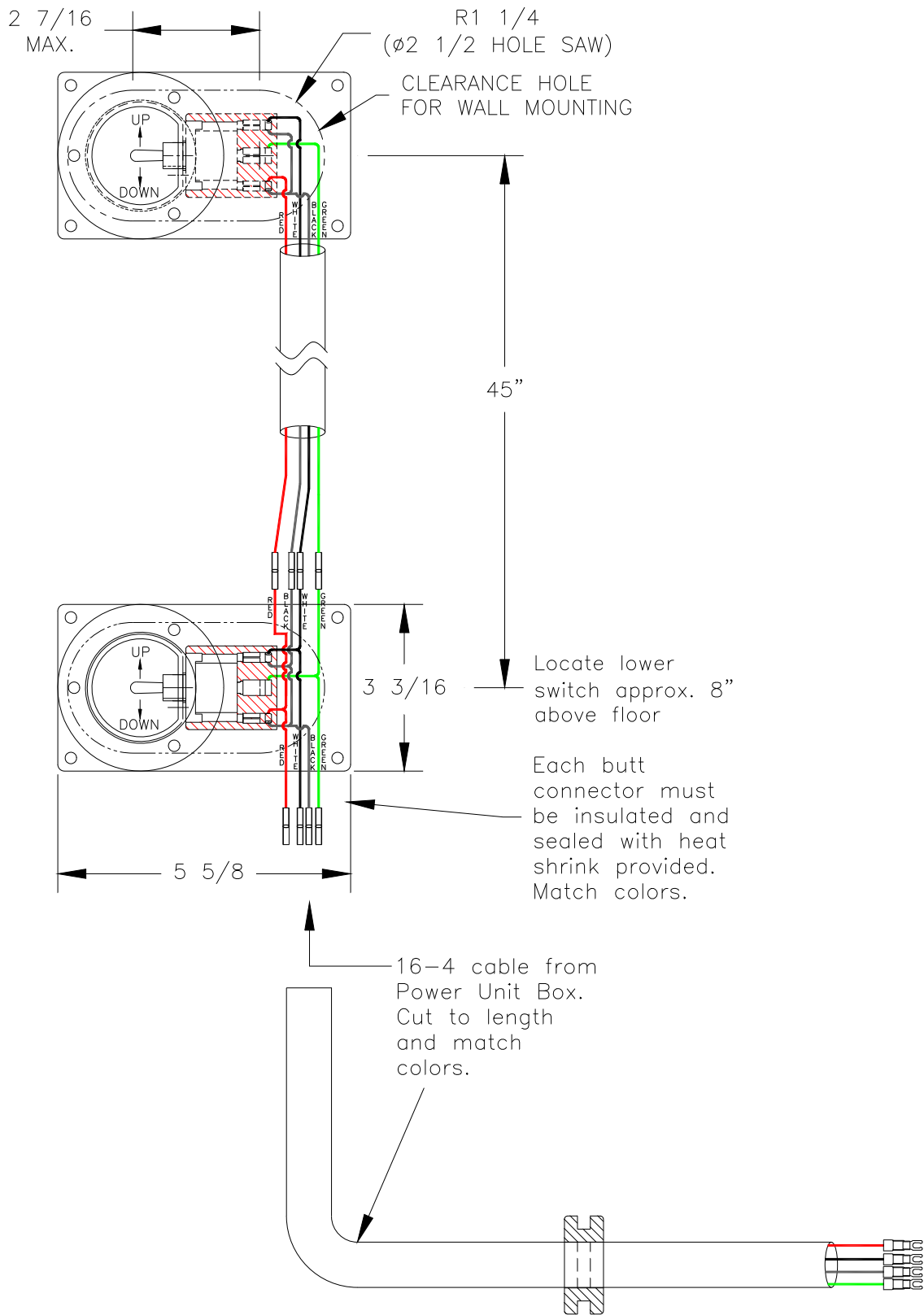
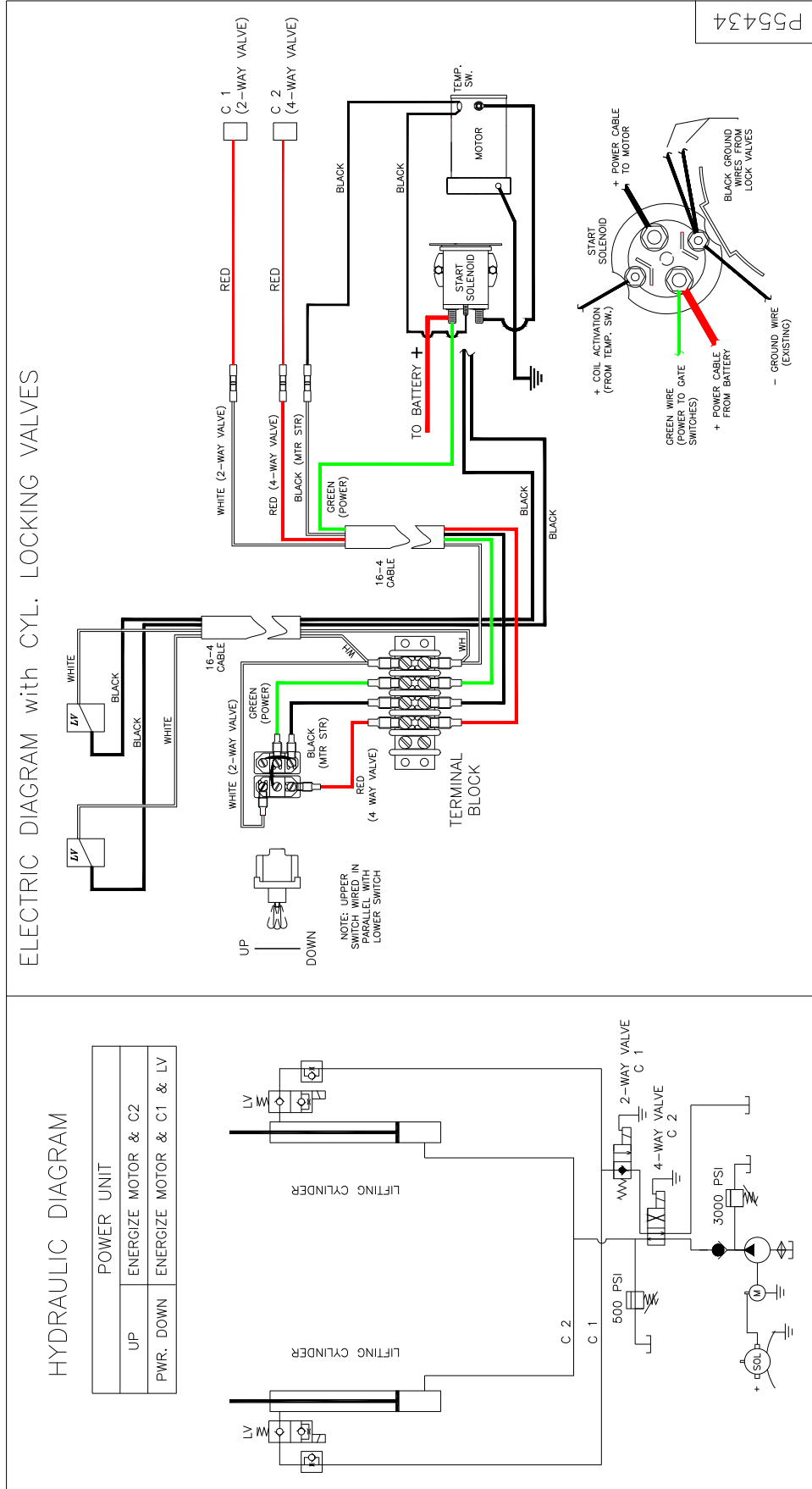

FIGURE 7 – LTS SWITCH LOCATION DIAGRAM



LTS WIRING / HYDRAULIC DIAGRAM



RECOMMENDED HYDRAULIC OILS*

Level 1

Normal Conditions

<u>Manufacturer</u>	<u>Type</u>	<u>Temperature Range</u>
Chevron	RYKON ISO-15	-15°F to 150°F
Mobil	DTE 11	-15°F to 150°F
Shell	TELLUS-T15	-15°F to 150°F

Level 2

Cold Conditions

<u>Manufacturer</u>	<u>Type</u>	<u>Temperature Range</u>
Chevron	AVIATION-A	-50°F to 80°F
Mobil	AERO-HFA	-50°F to 80°F
Shell	AERO FLUID #4	-50°F to 80°F
Mil	H-5606	-50°F to 80°F

*ISO 15 petroleum based fluid required; see chart for manufacturer cross reference. If necessary, use higher viscosity oil when temperatures are near 100° F.

* **DO NOT USE brake fluid or ATF.**

Recommended Grease

<u>Manufacturer</u>	<u>Type</u>
Militec	MILITEC #1 Grease

Recommended Electrical Terminal Sealer

<u>Manufacturer</u>	<u>Type</u>
Eureka	FLUID FILM SPRAY (all connections except Start Solenoid)
Loctite	COLOR GUARD (brush on Start Solenoid connections)

DECAL PLACEMENT

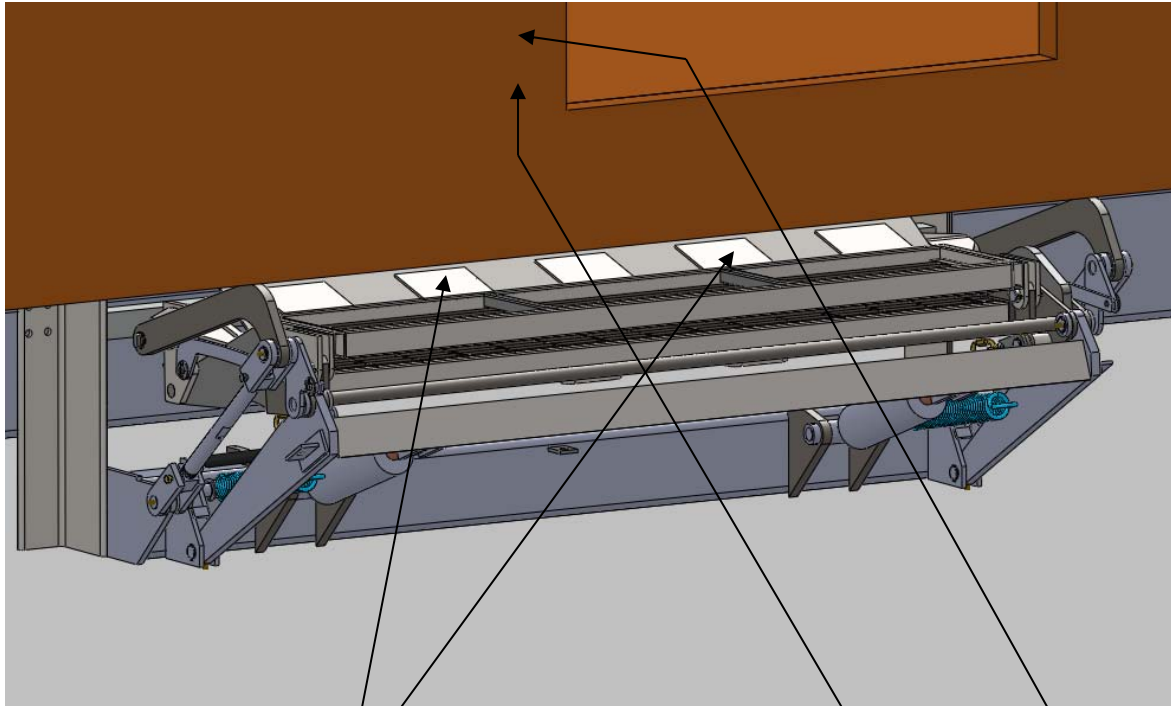

STAND CLEAR
(Bottom of Ramp)
P55429 (2)

Operation Instructions
P55427

Max Capacity Decal
P55297

UP / DOWN
Toggle Switch
P55221 (2)

Urgent Warning
P55199

Read and Understand
P55203

Shut Off Power
P55201

FINAL INSPECTION

CUSTOMER:		
LOCATION:		
VEHICLE#:	LIFT GATE MODEL#: LTS2000	LIFT GATE SERIAL#:

√ = OK

N = NOT APPLICABLE

	WELDING / ADJUSTMENTS
	Gate is securely to mounted vehicle (mounting angles are bolted to chassis frame using all bolt holes).
	Trunnion side plates are welded to mounting angles (welded all around).
	Reinforcement angle braces are installed by welding to opposite side of chassis.
	Power unit box welded or bolted secure to cross members.
	All bolts are tightened and secure.
	Cylinders are adjusted so platform stops at bed height.
	Platform slope is set at 3/8" (ramp higher than edge)
	Gate stops installed and correctly adjusted for over-the road folded position (Two 1/2-13 HHCS w/ jam nuts)
	Over-the-road safety chains and latches installed.
	ELECTRICS
	Check battery for proper charge level. PROPER CHARGE LEVEL:
	Check all wiring connections for tightness (batteries, switches, etc.)
	Inspect and check all circuit breakers/fuses.
	Power line to battery secure and protected from sharp edges.
	All connections and terminals protected with heat shrink
	Check operation of toggle switches
	HYDRAULIC / GREASE
	Check reservoir for correct amount of fluid (platform should open and at bed height when checking)
	Check hydraulic hoses and fittings for leaks
	Check cylinders for leaks.
	All grease fittings lubricated (16 total)
	OPERATION OF GATE
	Open and close lift gate. Observe for correct operation (platform folds and unfold properly)
	Raise lift gate (platform is level with floor of vehicle).
	Fold lift gate. Gate stops correctly in folded position when raised.
	PAINTING AND SAFETY STICKERS
	Touch up paint where needed
	Check hydraulic cylinder rods for over spray
	Install all safety and operation stickers

