

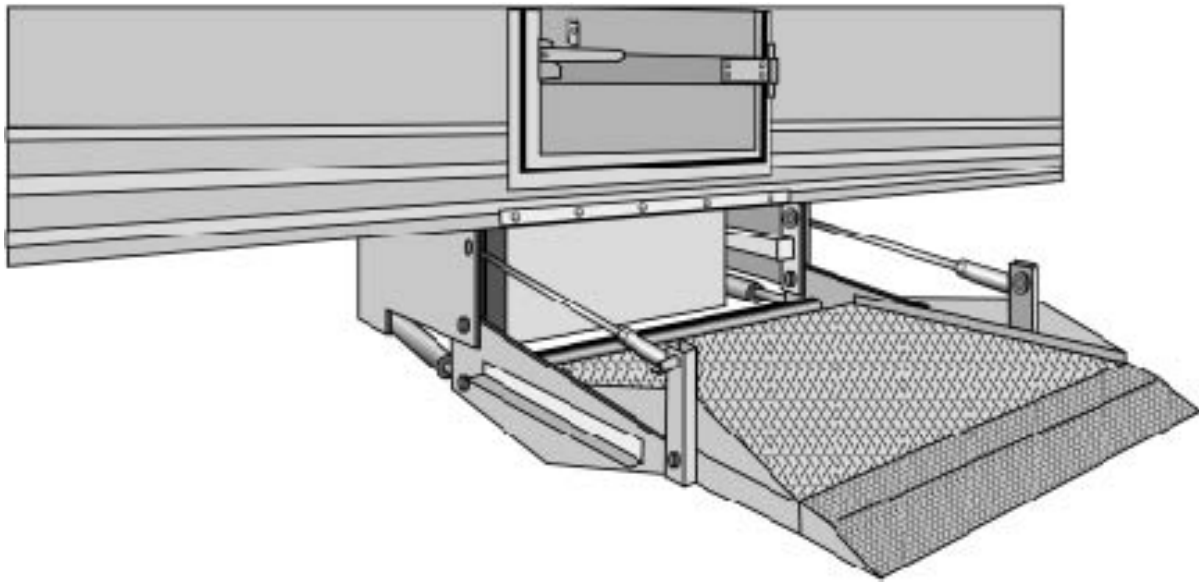

Owner's Manual

LPS4520RL Hide-A-Way®

Trailer Side Gate



LEYMAN MANUFACTURING CORPORATION
10335 Wayne Ave.
Cincinnati, OH 45215
1-866-LEYMAN-1 • 1-866-539-6261 • 513-891-6210
Fax 513-891-4901
www.leymanlift.com
sales@leymanlift.com

LML00454 03-18-2024

TABLE OF CONTENTS

General Specifications, Recommended Oils and Lubrication	3
General Terminology	4
Operating Instructions	5
Emergency Hand Pump Operation	6
Preventative Maintenance Schedule	7
Maintenance Minder 2 [®]	8 - 10
Installation Adjustments	11 – 12
Troubleshooting Chart	13
Wiring Diagrams	14 – 15
Grounding Recommendations	16
Power Unit Replacement Parts	17
Hydraulics – Interior Parts	18
Hydraulics – Bottom Side Parts	19
Replacement Bearings and Pins	20
Chain Area Replacement Parts	21
Dual Retention Ramp Parts	22
Emergency Hand Pump Parts (Opt. 184)	23
Basic Electrics / Replacement Parts	24 – 25
Toggle Switch Replacement Parts	26
Walk Around Electrics (Opt. 261)	27 – 28
Replacement of Safety Decals	29
Notes	30

GENERAL SPECIFICATIONS

CUSTOMER: _____
 MODEL: LPS _____
 SERIAL #: _____
 CAPACITY: 4500 lbs.
 TYPE: Trailer Side Door Lift Gate
 OPERATION: Power up/Gravity down
 Power in/out
 HYDRAULIC PRESSURE: 2500PSI – Up Function
 800PSI – In/Out Function

RECOMMENDED HYDRAULIC OILS / LUBRICATION

HYDRAULIC OILS	Manufacturer	Type	Temp. Range
Level 1 Normal Conditions	Mobile	DTE 11	-15° F to + 150° F
	Shell	TELLUS-T15	-15° F to + 150° F
	Exxon	UNIVIS-N15	-15° F to + 150° F
Level 2 Cold Conditions	Mobile	AERO-HFA	-50° F to + 80° F
	Shell	AERO FLUID#4	-50° F to + 80° F
	Exxon	UNIVIS-HV113	-50° F to + 80° F
	Mil	H-5606	-50° F to + 80° F
HYDRAULIC TANK CAPACITY			
2 ½ gallons			
LUBRICATION - GREASE			
Cam Rollers, Idler Sprockets, Auto-Lock shaft, cylinder pins, if grease fittings provided		Level 1 Normal Conditions NLGI #2 Lithium base grease Level 2 Cold Conditions NLGI #1 Lithium base grease DO NOT USE CHASSIS or 5 th WHEEL GREASE	
BATTERIES			
Two (2) 12-Volt DC Group 31 Heavy-Duty Dual Purpose or AGM			
ELECTRICAL COMPONENTS CONNECTIONS			
Use Fluid Film Rust & Corrosion Protection by Eureka, except on Start Solenoid. On Start Solenoid, use Color Guard by Loctite, or Liquid Electrical Tape			
AMPERAGE DRAW OF MOTOR			
When raising platform (empty) approximately 115 AMPS @ 13.5 volts. At bypass approximately 235 AMPS @ 13.5 volts			
LIFTING PRESSURE SETTING			
With platform at floor level and pump in bypass 2500PSI			
IN-OUT PRESSURE SETTING			
When sliding gate in-out and pump in bypass 800PSI			
MINIMUM VEHICLE FLOOR HEIGHT LADEN			
With any size of platform – vehicle floor height 48”			
MAXIMUM VEHICLE FLOOR HEIGHT UNLADEN			
With any size of platform – vehicle floor height 58”			
APPROXIMATE TIMES EMPTY AT 80° F WITH 2 GROUP 31 BATTERIES			
Time up: 14 – 18 seconds, Time down(gravity down): 12 –16 seconds			

WARNING:

The use of a battery charger as the sole power source to operate the lift gate is unauthorized and will prevent the lift gate from working properly. The lift gate must always be operated in conjunction with at least one (1) 12 volt heavy duty lift gate battery. A minimum of 9.5 volts must be maintained in order for the DOWM valve and 10.5 volts for the IN / OUT valves to operate.

GENERAL TERMINOLOGY

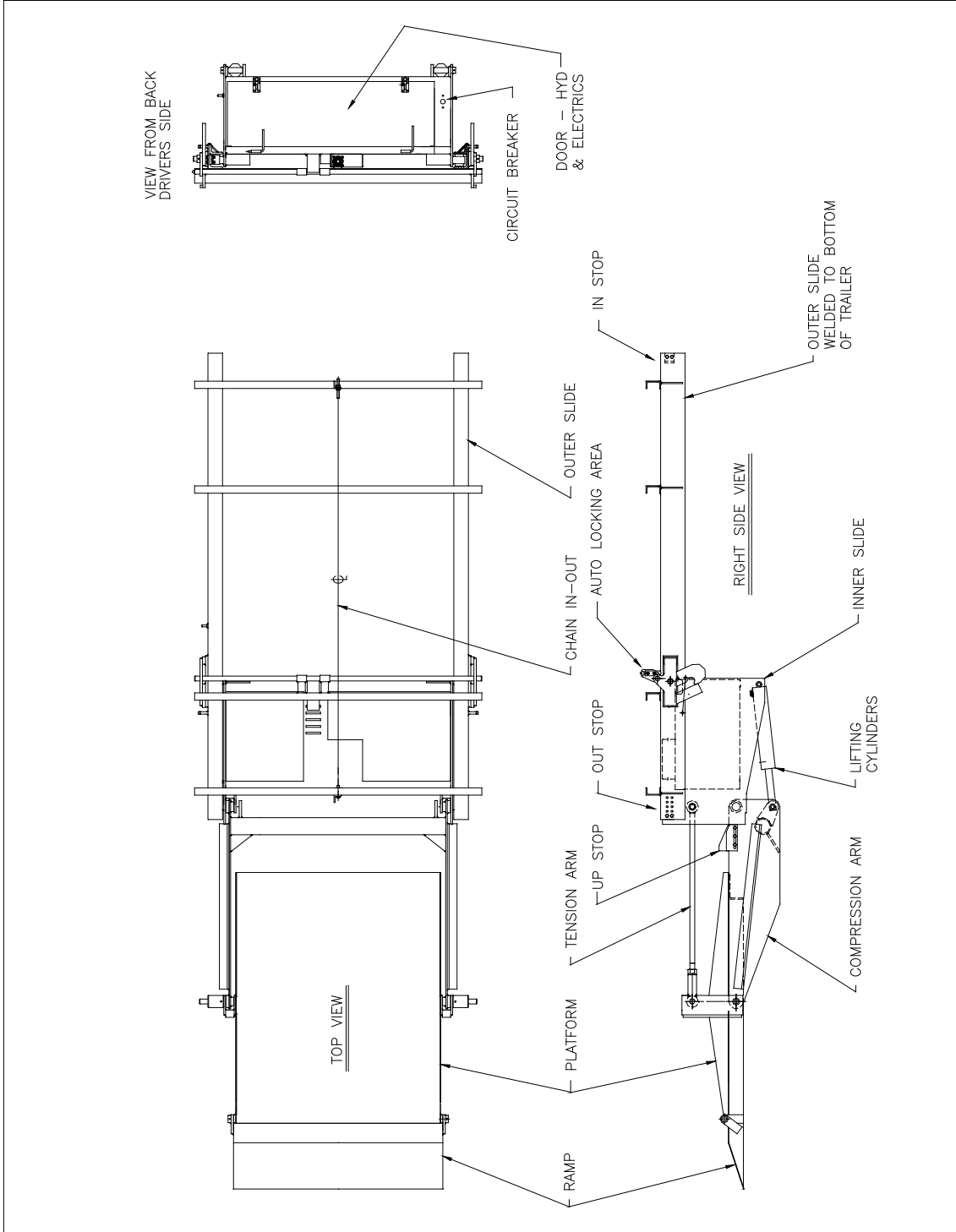

OPERATING INSTRUCTIONS

Before operating the lift gate, read and understand Urgent Warning decal and Owner's Manual.

Do not stand in front of the lift gate while unfolding or using the platform.

With the gate in the over-the-road / stored position, do the following steps to operate the gate:

1. To relieve the tension on the auto lock, push the up switch (gate will go up), pull the handle to release auto lock.
2. Use the down switch to lower lift until arms are parallel to the ground.
3. Stand to the side of the lift gate. Push the power in/out switch down, gate will run out, run the gate out until it stops and locks into its fully extended position.
4. Unfold ramp.

To lower the platform, use the down switch only.

To raise the platform, use the up switch only.

To store the gate in over-the-road position:

1. Raise the platform off the ground until the arms are parallel to the ground.
2. Fold ramp over.
3. Raise locking bar handle and push the in/out switch up. Run gate all the way under trailer until the lift stops.
4. Run gate up (use the up switch), auto lock will latch.
5. Lower the gate until resting on the auto lock. (Use the down switch).

EMERGENCY HAND PUMP OPERATION

If an emergency hand pump was supplied with this lift gate, its intended use is to restore the gate to the transit position.

CAUTION: Do not try to operate the power unit when using the hand pump.

Steps to secure the gate, so the trailer can be moved:

1. Remove the pump handle from the holder and insert into the hand pump socket.
2. Raise the platform off the ground about 6", pump up/down.
3. To retract the gate, disconnect the IN/OUT chain and manually push the gate under the trailer all the way until it stops.
4. Pump the gate until fully up. Gate must latch into the Auto-Lock hooks.
5. With the handle unscrew the valve on the bottom of the hand pump. This will let the gate rest down in the Auto-Lock hooks.

PREVENTATIVE MAINTENANCE

1. Lubrication
Most pivot points have greaseless bearings, so no lubrication is required. Grease fittings are located at the Cam Rollers, idler sprockets, Auto-Lock shaft supports, and cylinder pins. See Preventative Maintenance Schedule and recommended greases.
2. Hydraulic
With the platform on the ground, check the oil level. Fill to about 1" from the top of the tank. See recommended hydraulic oils
3. Electrical
Check for corrosion and/or loose connections.

PREVENTATIVE MAINTENANCE SCHEDULE

MAINTENANCE by CYCLES

MODEL LPS4510RL

DATE: _____

CUSTOMER		GATE MODEL #	
LOCATION		GATE SERIAL #	
VEHICLE #		SERVICED BY	

√ = OK X = REPAIR A = ADJUSTED N = NOT APPLICABLE

3000	MOTOR / PUMP COMPONENTS	3000	MOTOR / PUMP COMPONENTS
	Check batteries for corroded, loose or broken connections		Check charge line/power line for corroded, loose or broken connections at both ends
	Check batteries for proper voltage level and charging		Check amp draw of motor with fully charged batteries and tight clean connections
	Check all wiring in pump box for corroded, loose or broken connections		Check all ground wires for corroded, loose or broken connections
	Check power unit solenoids for proper operation		Check pressure setting of relief valves
	Check reservoir for proper oil level (Gate down on the ground, fluid level should be 1" from top of tank)		Clean all wiring connections in pump and battery box. Spray with Fluid Film Corrosion Protection by Eureka. Use Color Guard or Liquid Electrical Tape on Start Solenoid.
	Inspect circuit breakers and fuses for proper operation		Check emergency hand pump for proper operation if equipped.
	Check all fittings/hoses in power unit for tightness and leaks		Check hydraulic motor sprockets for worn bushings and proper operation.

3000	STRUCTURAL COMPONENTS	3000	STRUCTURAL COMPONENTS
	Check for correct operation of the gate UP, DOWN, IN, and OUT.		Check IN/OUT chain for proper adjustment (no more than 1/2" play)
	Check wiring harness on side of gate for chaffed, frayed, or broken wires.		Check all pivot points for loose, broken, or missing roll pins
	Check wiring harness on side of gate for loose, broken, or missing clamps.		Check UP stops for proper positioning of the platform and adjust as needed.
	Check the ground cable on side of gate for loose or corroded connections.		Check the IN/OUT stops for loose, broken, or missing hardware
	Check hydraulic cylinders for leaks		Check rollers for proper operation
	Check hydraulic cylinder pins for loose, broken, or missing roll pins.		Check over-all gate for damage or broken welds and repair as needed.
	Check Auto Lock mechanism for proper operation. Lubricate and adjust as needed.		Check Compression and Tension Arms for worn bushings
	Check all warning lights for proper operation if equipped		

3000	LUBRICATION		PERIODICAL CHECK LIST
	Stainless Steel Chain should not require any lubrication. Lubricate Idler Sprockets, Auto-Lock shaft, Cam Rollers, and Cylinder Pins at base end.	12000	Check all pivot point bushings for wear or damage
		12000	Check hydraulic motor sprockets for worn bushings and proper operation.
		15000	Flush hydraulic system and change hydraulic oil
			Clean and repaint as necessary

MAINTENANCE MINDER ² READINGS MENU 2			
Screen 1 # Lifts	Screen 3 Service Faults	Screen 4 Low Voltage Faults	Screen 6 High Temperature Faults

TO RESET MAINTENANCE MINDER 2[®] after performing Preventative Maintenance, see page 8.

MAINTENANCE MINDER 2® OVERVIEW

Power unit is equipped with the Maintenance Minder 2® Controller. It will:

- Automatically keep track of maintenance intervals and warn the user when maintenance is due, based on the number of lifts.
- Record low voltage occurrences.
- Record high temperature faults.
- Record maximum run time faults, when a single operation exceeds the maximum continuous run time limit.
- Give helpful trouble-shooting information on MENU 4, “Last Lift Info”.

FAULTS CODES

A decal in the power unit enclosure lists the following signal codes for these faults:

1 BEEP	Service Fault (reached the number of lifts when maintenance is due)
2 BEEPS	Low Voltage Fault (check battery condition and power line connections)
3 BEEPS	Max. Time Fault (exceeded the maximum continuous run time allowed)
4 BEEPS	High Temperature Fault (unit will not run until motor cools)

All faults signals will be repeated FOUR times, except the Service Fault signal. Controller will prevent power unit from operating during the time period when a fault signal is sounding (about 5 to 10 sec.) except for the Service Fault signal. The controller is also equipped with an anti-doorbelling feature, which prevents rapid ON/OFF operation of the power unit.

RESETTING after MAINTENANCE IS PERFORMED

To RESET the Maintenance Minder 2® after maintenance has been performed:

1. Go to MENU 2, hit “ENTER”, and toggle down to the “Reset All Info” screen.
2. Press and hold the hidden RESET button under Maintenance Minder 2® logo at top of faceplate.
3. Follow the instructions on the screen regarding a second button, which must be pressed to complete the reset operation.



MAINTENANCE MINDER 2® CONTROLLER MENUS

(Press MENU)

MENU 1 – LIFT GATE INFO

(Press ENTER, then ARROW DOWN for each item)

Model Number, Serial Number, Manufacture Date, Vehicle ID, Hardware Version, Firmware Version, Software Version.



(Press MENU and ARROW DOWN once)

MENU 2 – PERIOD INFO (data for current maintenance period)

(Press ENTER, then ARROW DOWN for each item)

Number of Lifts (gives the number during this maintenance interval and the set number when maintenance is due)

Motor ON (total motor run time in minutes for this maintenance period)

Service Fault (number of times gate was operated PAST the maintenance limit)

Max. Time Faults (times motor exceeded its maximum allowable continuous run time)

High Temperature Faults (times thermal switch in motor tripped, if switch provided)

Low Voltage Faults (times low voltage occurred)

Reset all Info (Reset data after performing maintenance, once maintenance limit is reached – see reset instructions on previous page)



MAINTENANCE MINDER 2® CONTROLLER MENUS

(Press MENU and ARROW DOWN twice)
MENU 3 – LIFE TIME INFO (data for the total life time of the gate)

(Press ENTER, then ARROW DOWN for each item)

Same items will appear as under PERIOD INFO, except this is LIFE TIME data.

Reset History (reviews history for each maintenance interval)

Press ENTER, then ARROW DOWN to show history. Most recent period is the highest #. Screen shows Period #, # of Lifts, and Total Run Time in minutes.



(Press MENU and ARROW DOWN three times)

MENU 4 – LAST LIFT INFO (Trouble Shooting Screen – it records data that occurred during the last lift made)

(Press ENTER, then ARROW DOWN for each item)

Supply Voltage (first voltage is the minimum voltage that occurred during the last lift – if below 6 volts gate will stop / second voltage is the supply voltage just before gate operation, must be at least 10 volts).

Motor ON (motor run time in seconds during last lift, gate will stop at 180 seconds).

Window Time (time in milliseconds during the last lift that the voltage dropped in between 6 and 8 volts – must not be any longer than 3 seconds or gate will stop).



NOTE:

Controller has an anti-doorbelling feature. Motor will not operate if UP switch is toggled rapidly. This prevents welding of the start solenoid contacts.

INSTALLATION ADJUSTMENTS

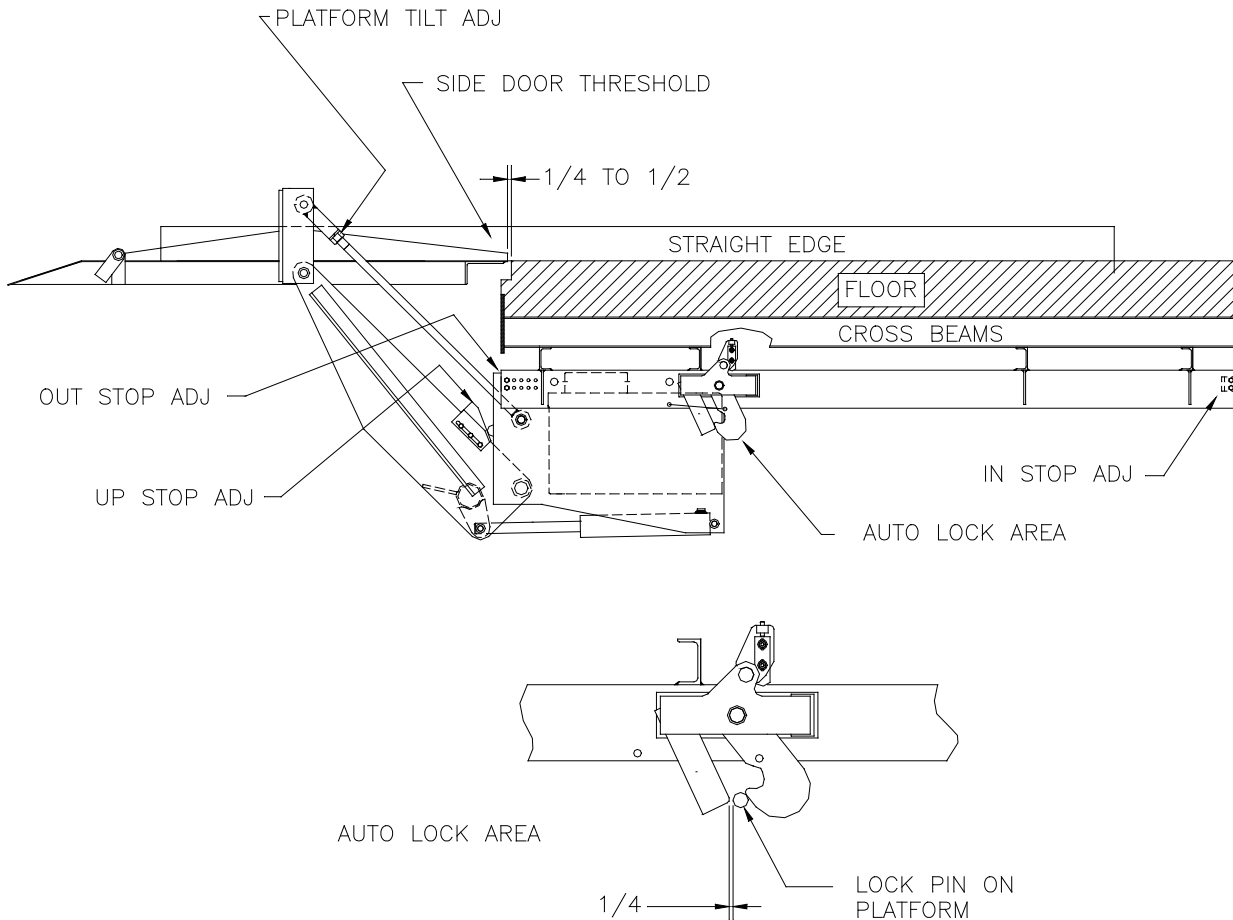

- Step 1: The platform was preset at the factory to be level to the floor of the trailer within $\frac{1}{4}$ ". With a straight edge, check this. If it is okay, proceed to step 2. If not, let the platform down to the ground. Remove the two (2) roll pins and the top Tension Arm pivot pins (one on each side).
NOTE: One full turn moves the tip of the platform $\frac{1}{4}$ " (turn the end in, this moves the tip of the platform up, unscrewing moves the tip of the platform down). Make necessary adjustments. Replace pins, raise the platform up and check. Repeat if necessary. Replace roll pins.
NOTE: Each side must be adjusted the same amount.
CAUTION: If this adjustment has been made, the IN stops must be adjusted to provide the $\frac{1}{4}$ " clearance with the Auto Lock pin (see lower sketch).
- Step 2: Adjust the UP stops. Platform should be even with the floor of the trailer.
- Step 3: Adjust the OUT stops. The tip of the platform should be $\frac{1}{4}$ " to $\frac{1}{2}$ " from the edge of the threshold.
- Step 4: Adjust the IN stops. See lower sketch and adjust for the $\frac{1}{4}$ " dimension

INSTALLATION ADJUSTMENTS

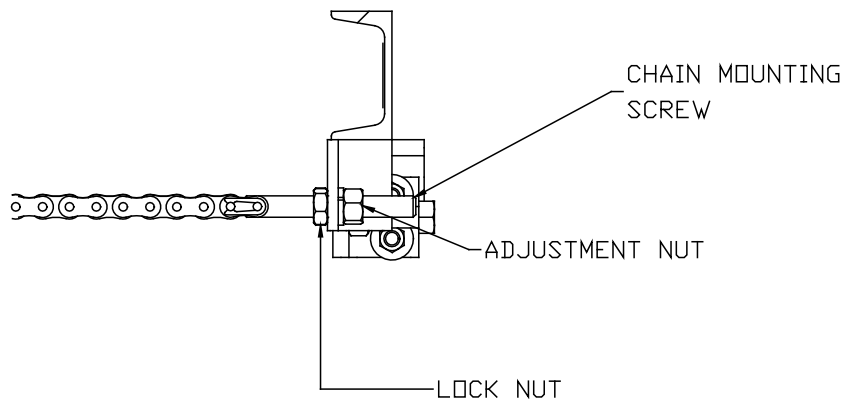
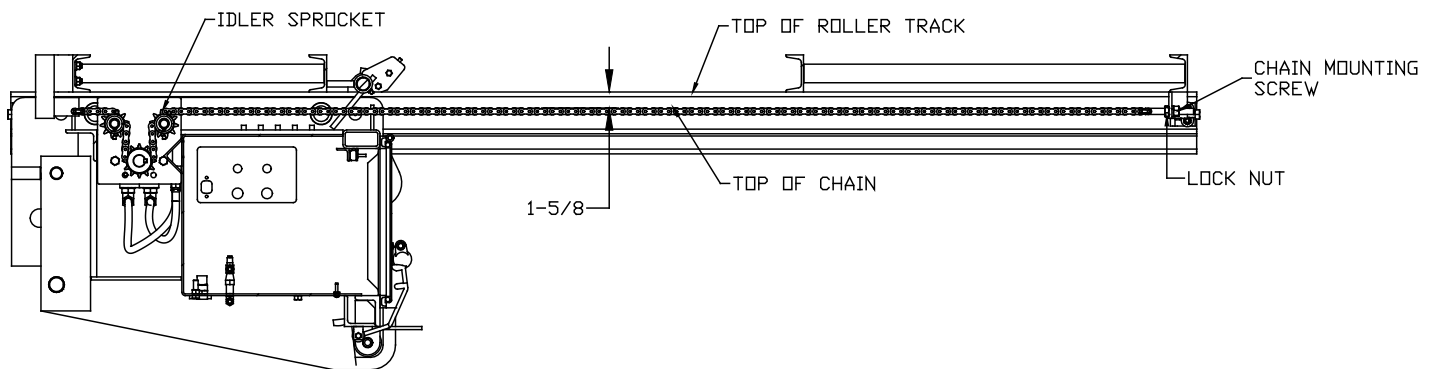

- Step 5: Ensure the platform is fully out before taking chain measurements or adjusting. Measurements should be taken at the halfway distance from the chain mounting screw to the idler sprocket (approximately where the measurement is in the top picture). The chain should have 1/8" to 1/4" of sag. Another way to measure is from the top of the roller track to the top of the chain, which is between 1-5/8" and 1-3/4".
- Step 6: Adjust the chain tension via the Chain Mounting Screw. Loosen both nuts at the same time. Unscrew the lock nut with a few extra threads for tightening. Use the adjustment nut to make the adjustment. To add tension to the chain, rotate the nut clockwise. To loosen chain tension, rotate the nut counterclockwise. To lock the tension adjustment, tighten the lock nut while maintaining the position of the adjustment nut.
- NOTE:** Ensure the chain is not twisted to ensure sprocket engagement.
- NOTE:** Chains will stretch a small amount over time. Chain tension should be adjusted as a part of regular maintenance if necessary.
- CAUTION:** Overtightening the chains will result in the gate seizing during in and out operations, which will prohibit movement.

TROUBLESHOOTING CHART

PROBLEM	PROBABLE CAUSE	REMEDY
The motor is running, but the platform will not go up or reach the floor of the vehicle.	<ol style="list-style-type: none"> 1. Insufficient oil in power unit tank. 2. Platform is over-loaded. 3. Pressure setting is low. 	<ol style="list-style-type: none"> 1. Fill tank to the appropriate level. 2. Load only to the rated capacity. Remove some product if necessary. 3. Check and adjust the pressure to the proper setting.
The platform will not go up or reach floor level and the motor does not run.	<ol style="list-style-type: none"> 1. Low battery. Check Maintenance Minder 2[®] for Low Voltage faults. 2. Tripped circuit breaker. 3. Power line is loose. 4. Bad motor, starter or switch 	<ol style="list-style-type: none"> 1. Recharge or replace battery. 2. Reset the circuit breaker. 3. Check the connections. If loose, tighten. Check for corrosion and clean if necessary. 4. To test-push the UP switch, if motor does not run, jump the two large terminals on the starter solenoid. The motor should run, if not, the motor is bad. If it does run, the solenoid is bad or is not getting a signal from the switch or the MM2. Use a test light to check.
Platform will not lower.	<ol style="list-style-type: none"> 1. Low battery. Need 10.5 volts to activate valve coils. 2. Bad ground or poor electrical connections. 3. Solenoid valve not opening. 4. Mechanical obstruction in gate. 	<ol style="list-style-type: none"> 1. Recharge or replace battery. 2. Check connections, if loose-tighten. Check for corrosion and clean if necessary. 3. Drain valve "C" valve (white wire) must activate when DOWN switch is pushed. Use test light to check. 4. Visually check.
Platform creeps down.	<ol style="list-style-type: none"> 1. Hydraulic leak. 2. Defective piston seal in cylinder. 3. "C" valve (white wire), or check valve not closing. 4. Drain valve at base of optional Hand Pump may be open. 	<ol style="list-style-type: none"> 1. Visually check for leaks. 2. Replace seals or cylinder. 3. Clean and inspect. 4. Check to see if valve on Hand Pump is closed tightly. Use end of Hand Pump handle.
Platform goes down slowly.	<ol style="list-style-type: none"> 1. Check for obstructions or damage to arms. 2. Restricted or pinched hydraulic lines. 3. "C" valve (white wire) not opening. 4. Incorrect hydraulic oil for cold weather operation 	<ol style="list-style-type: none"> 1. Visually check. 2. Check for bent or pinched lines. 3. Clean and inspect. 4. Use recommended hydraulic oils for conditions present.
Gate will not go OUT and/or IN.	<ol style="list-style-type: none"> 1. Check for obstructions in rails. 2. Low battery. Check Maintenance Minder 2[®] for Low Voltage faults. 3. Tripped circuit breaker. 4. Power line is loose. 5. Bad motor, starter or switch. 	<ol style="list-style-type: none"> 1. Visually check. Check Side Button adjustment 2. Recharge or replace battery. 3. Reset the circuit breaker. 4. Check the connections. If loose, tighten. Check for corrosion and clean if necessary. 5. To test: push OUT switch and motor does not run, jump the two large terminals on the starter solenoid. The motor should run, if it does not run, you have a bad motor. If it does run, the solenoid is bad or it is not getting a signal from the switch. Use test light to check (OUT is "A" valve "red wire", IN is "B" valve "orange wire").

CIRCUIT BREAKER WIRING DIAGRAM

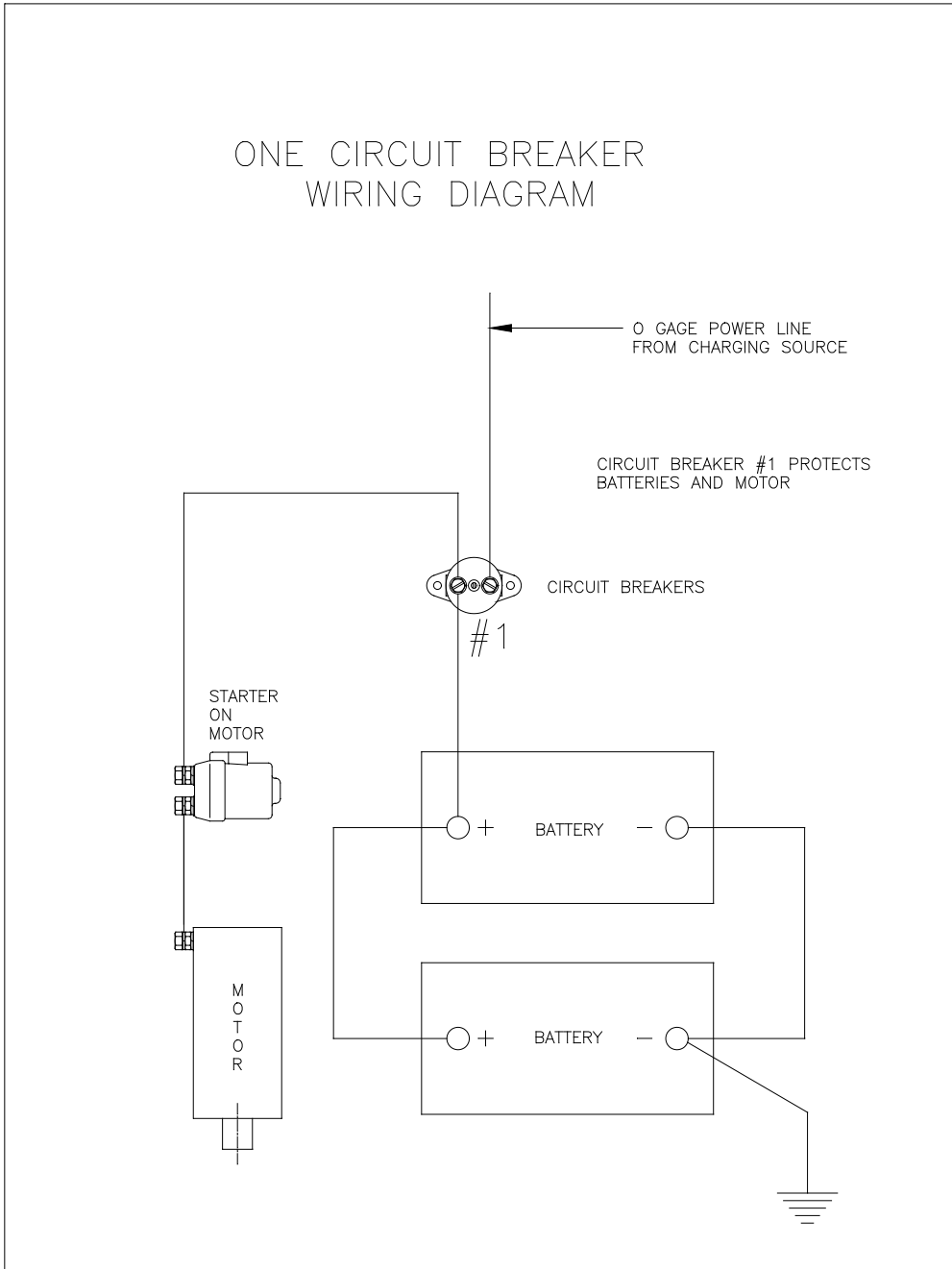

GROUNDING RECOMMENDATIONS

FOR TRACTOR/TRAILER USING MAINTENANCE MINDER 2[®] CONTROLLER

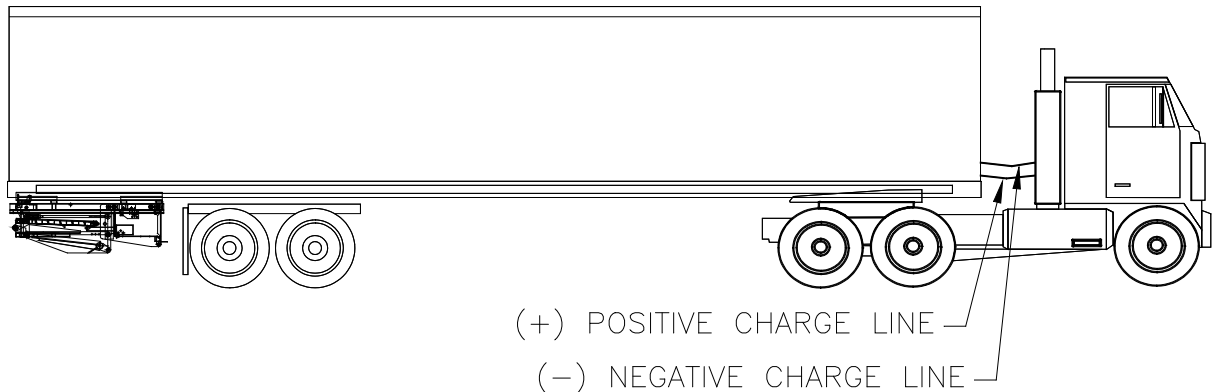

The Maintenance Minder 2[®] Controller requires a minimum of 10 volts to start and 8 volts to continue running the LPR lift gate. Power unit solenoid valves will require 10.5 volts to operate the coils. Utilization of a single positive cable often does not provide a sufficient ground for the charging circuit. Therefore, our recommendation for grounding tractor/trailers with the LPR gate is as follows:

Use two (2) cables, one (1) positive and one (1) negative, both running to the tractor batteries.

NOTE:

The use of a battery charger as the sole power source to operate a LPR is unauthorized and will prevent the LPR from working properly. The lift gate must always be operated in conjunction with at least one (1) 12 volt heavy-duty dual purpose or AGM lift gate battery. A minimum of 10.5 volts must be maintained in order for the valves to operate.

POWER UNIT REPLACEMENT PARTS

BUCHER POWER UNIT

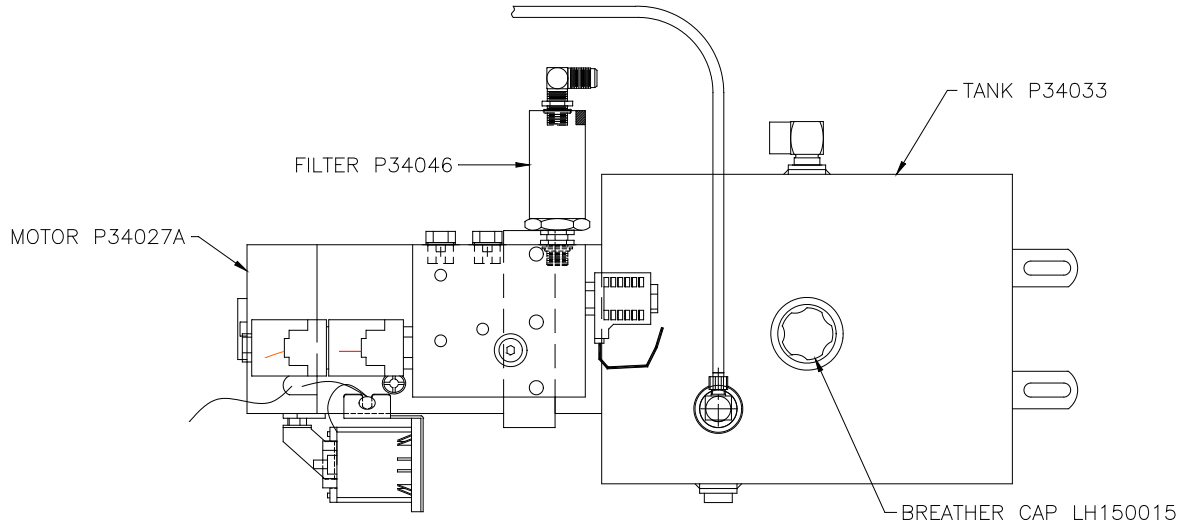

TOP VIEW

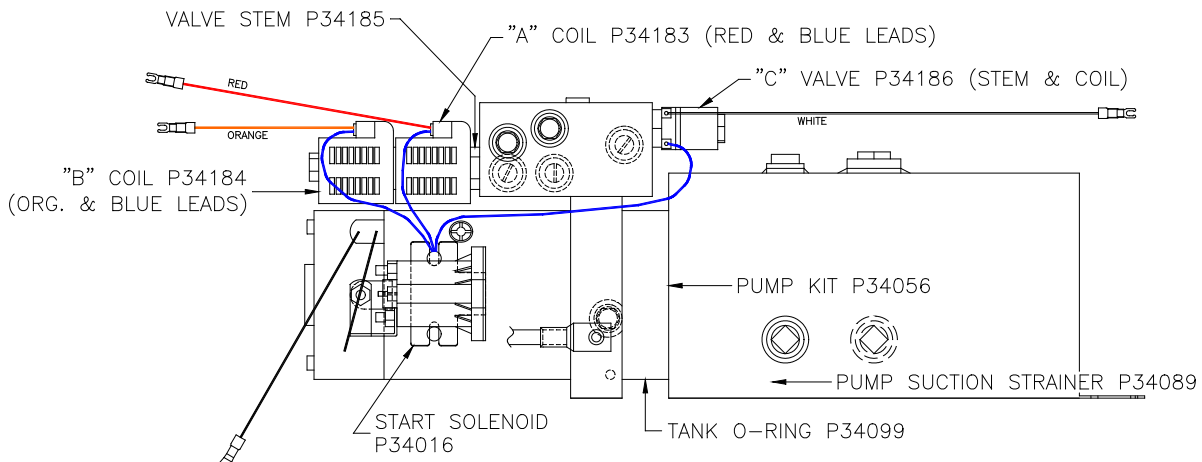

FRONT VIEW

COMPLETE POWER UNIT (LESS FILTER AND FITTINGS) P34171

MAINTENANCE MINDER 2[®] CONTROLLER P46608H

HYDRAULICS - INTERIOR PARTS

PART NO.	GATE WIDTH	ITEM 9 BATT. CABLE SUB ASSEMBLY	ITEM 9 LENGTH
D1-817-896-001	42	AT-501-354-026	36 IN
D1-817-896-003	48	AT-501-354-029	39 IN
D1-817-896-003	60	AT-501-354-045	45 IN
D1-817-896-004	72	AT-501-354-051	51 IN

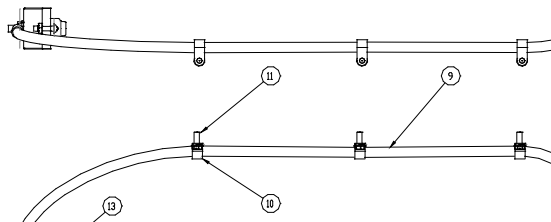
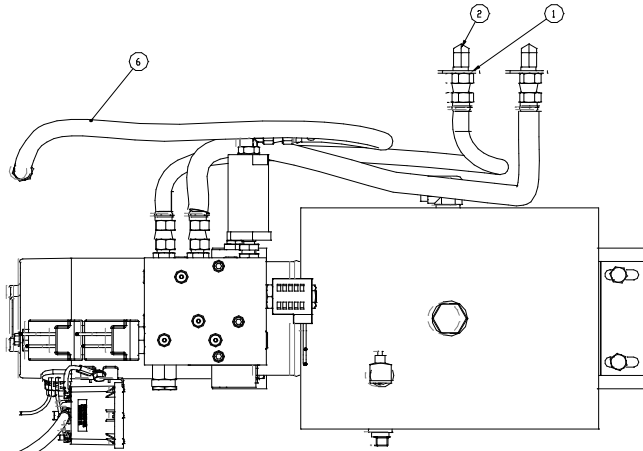

ITEM NO.	QTY.	PART NUMBER	DESCRIPTION	MATERIAL	MATERIAL SIZE	#DIMNS	WGT.
17	2	P1052P	HMS 3/8 X 1-1/4 PLATED G2				
16	2	P230U	LOCK NUT, HEX	304 SS	STDYD, UNK. 1		
15	2	P1000U	HMS 3/8-16 X 1-1/2 G2 PLATED				
14	4	P1000U	FLAT WASHER	304			
13	2	P230M	NUT	304 SS FLD-CLD, PLATED			
12	2	P19534	ROUND HEAD MACHINE SCREW	304 SS	3/4 X 1 1/4 LG IS		
11	3	P1730B	SELF-TAPPING SCREW	304 SS	1/2 X 1 1/2 LG IS		
10	3	P4625B	LEAD CLAMP 1/2"				
9	1	SEE CHART	2 GA. BATTERY CABLE SUB ASSY		SPECIAL NUMBER IS STAMPED ON CABLE		
8	4	JAP-817-838	PLASTIC SPACER				
7	1	P46864	CIRCUIT BREAKER 150 AMP				
6	1	AT-501-354-027	HYDRAULIC LINE 27" LONG				
5	1	CA-501-443	BOILER POWER UNIT				
4	1	AT-501-354-023	HYDRAULIC LINE 23" LONG				
3	1	AT-501-354-018	HYDRAULIC LINE 18" LONG				
2	2	P34106	BEARHEAD ELBOW W/ NUT		LR 30		
1	2	P1000U	FLAT WASHER				

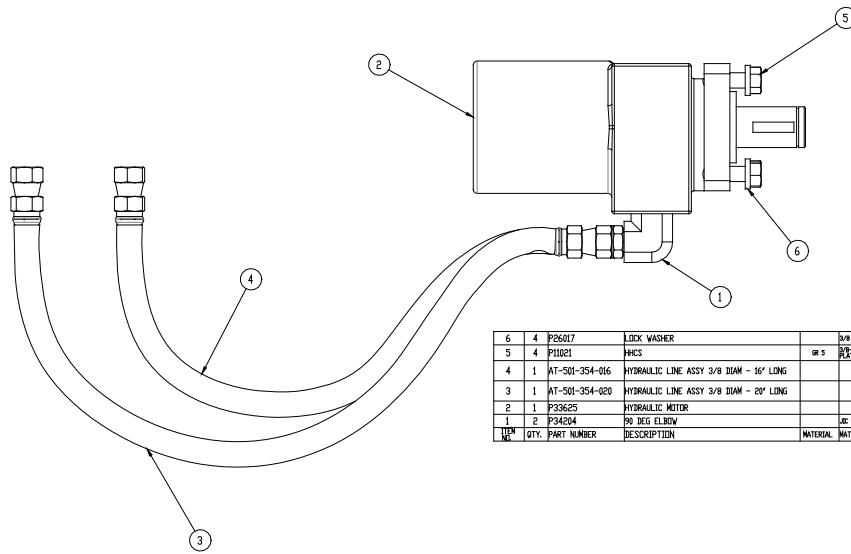
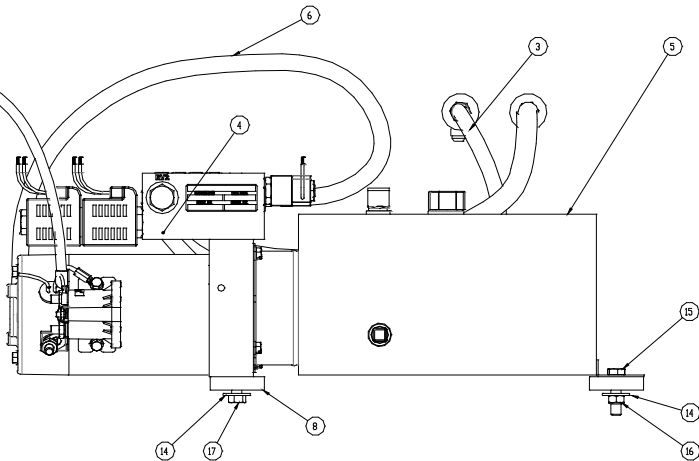

ITEM NO.	QTY.	PART NUMBER	DESCRIPTION	MATERIAL	MATERIAL SIZE	#DIMNS	WGT.
6	4	P26017	LOCK WASHER	304			
5	4	P11021	HMS	304 SS	3/8 X 1 1/4 @ 5		
4	1	AT-501-354-016	HYDRAULIC LINE ASSY 3/8 DIAM - 16" LONG				
3	1	AT-501-354-020	HYDRAULIC LINE ASSY 3/8 DIAM - 20" LONG				
2	1	P33625	HYDRAULIC METER				
1	2	P34204	90 DEG ELBOW		LR 30 - 30 90		

HYDRAULICS BOTTOM SIDE PARTS

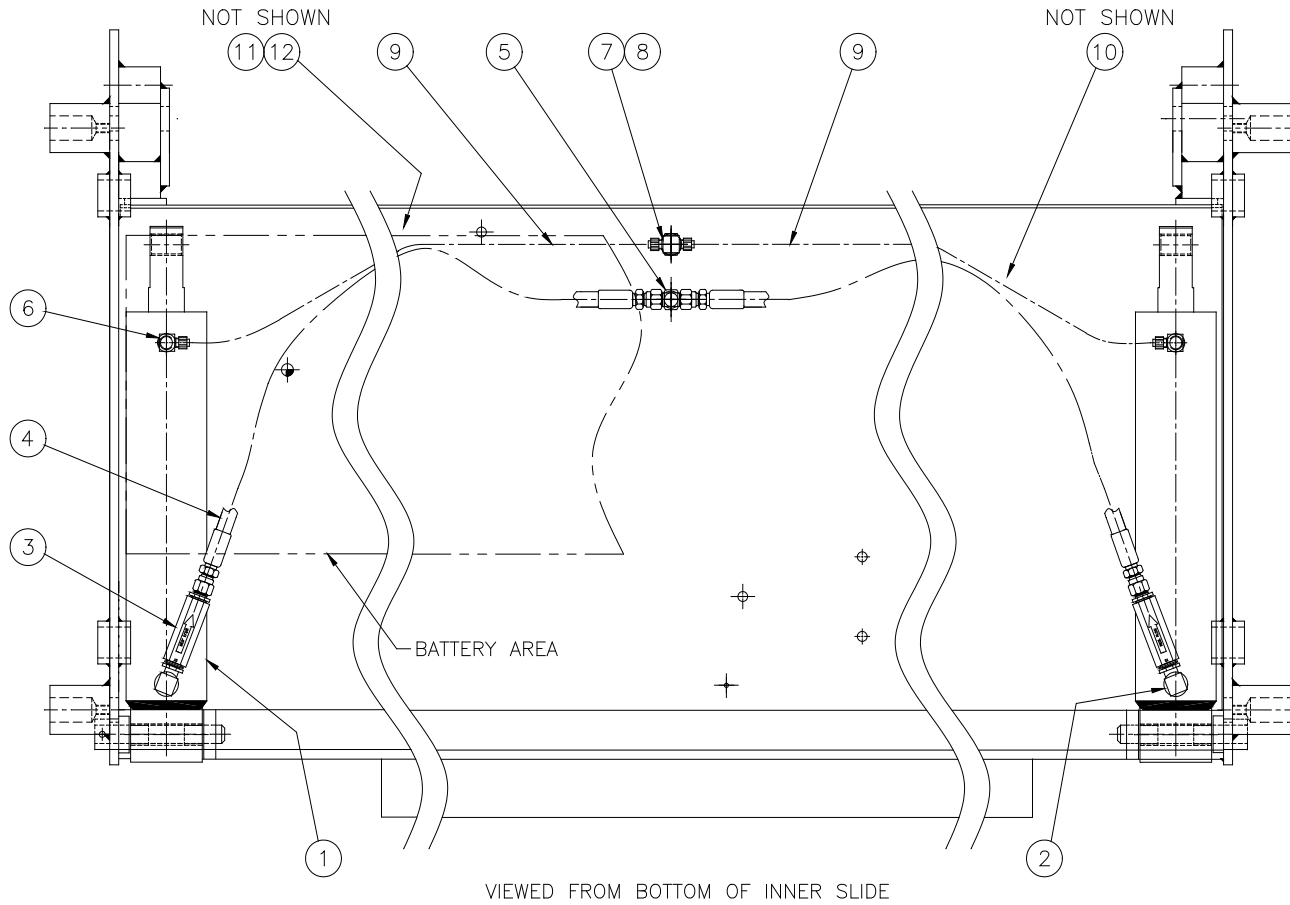

Index No.	Req'd	Part No.	Description	Comments
1	2	P34182	HYDRAULIC CYLINDER	3" BORE x 12" STROKE
2	2	P34041	MALE ELBOW	SAE O-RING (M) – SAE O-RING (M)
3	2	P34161	FLOW CONTROL	2.0 GPM
4	2	AT-501-354-040	HYDRAULIC LINE	
5	1	P34105	BULKHEAD TEE	
6	2	P33932	BRASS MALE ELBOW	
7	1	P33699	BRASS TEE	1/4 NPT TO 1/4 TUBE
8	1	P33617	REDUCER	3/8 NPT – 1/4 NPT
9	2	P33702-037	1/4 " POLY TUBE	
10	4	P46335	WIRE TIE	
11	2	P46251	LOOM CLAMP	
12	2	P17518	SELF-TAP SCREW	

REPLACEMENT BEARINGS AND PINS

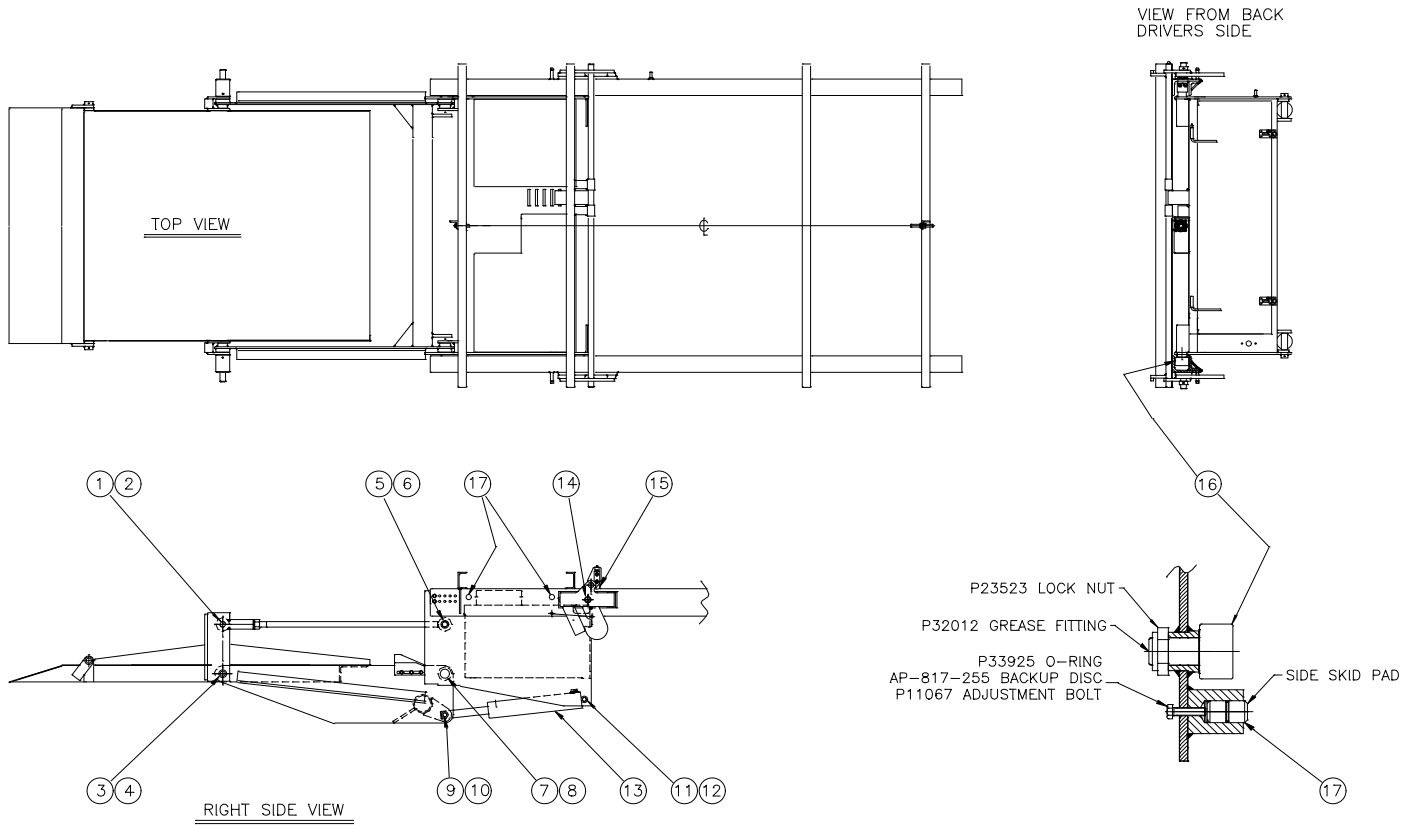

Index #	Req'd	Part #	Part Name	Matl. Size
1	2	P43567	Bearing	1 id. x 1-1/2 lg.
2	2	BA-817-844 / BP-817-472	Pin & Boss / Pin only	1 dia. x 7-5/8 lg.
3	2	P43567	Bearing	1 id. x 1-1/2 lg.
4	2	AP-817-842	Pin (Comp Arm to Platform)	1 dia. x 3-5/8 lg.
5	2	P43567	Bearing	1 id. x 1-1/2 lg.
6	2	AP-817-842	Pin (Tension arm to Inner)	1 dia. x 3-5/8 lg.
7	2	P43566	Bearing	1-1/4 id. x 1-1/2 lg.
8	2	AP-817-843	Pin (Comp Arm to Inner)	1-1/4 dia. x 3-5/8 lg.
9	4	P43620	Bearing (cyl. rod end)	3/4 id. x 5/8 lg.
10	2	AA-817-742	Pin Kit (Rod end w/hdw)	3/4 dia. x 3-3/4 lg.
11	4	P43573	Bearing (cyl. base end)	3/4 id. x 3/4 lg.
12	2	AA-817-743	Pin (Base end w/hdw)	3/4 dia. x 6-1/8 lg.
13	2	See Pages 20 - 22	Hyd. Cylinder	
14	2	P43570	Bearing	1 id. x 1/2 lg.
15	2	AP-817-233	Skid Pad	Pushes "J" Hook
16	4	P37544	Roller	Ref. P23523Nut & P32012 Gr. Fitting
17	4	AP-817-044	Side Skid Pad	1 od. x 1-13/16 lg.
	8 ea.	P11062 and P23502	Bolt and Lock Nut	Use w/items 4, 6, 10, 12
	2 ea.	P11063 and P23502	Bolt and Lock Nut	Use w/item 8
	2	P47538	Roll pin	Use w/item 2
	8	P32016	Grease Fitting	Use w/items 2, 4, 6, 8

CHAIN AREA REPLACEMENT PARTS

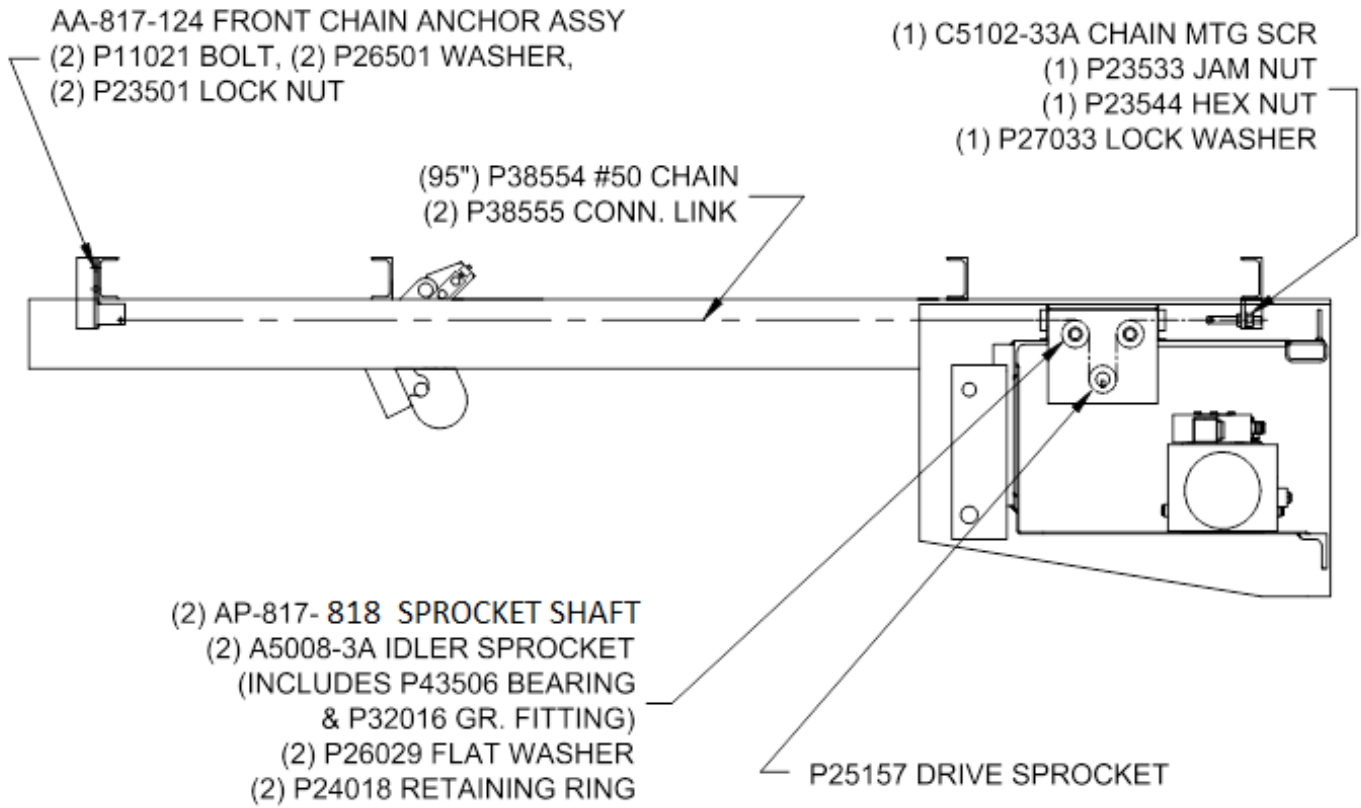

DUAL RETENTION RAMP PARTS (Std.)

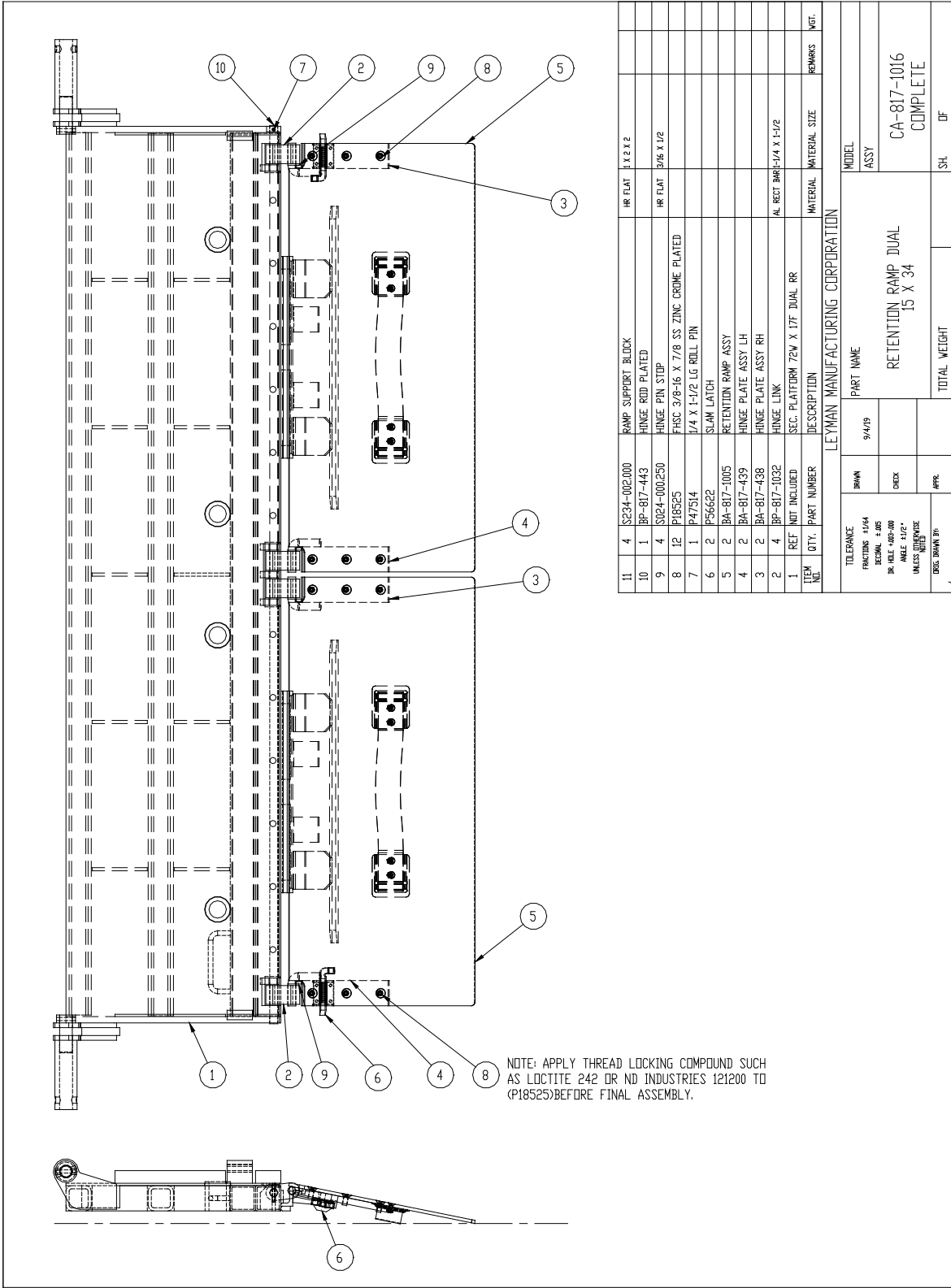

EMERGENCY HAND PUMP OPTION #261

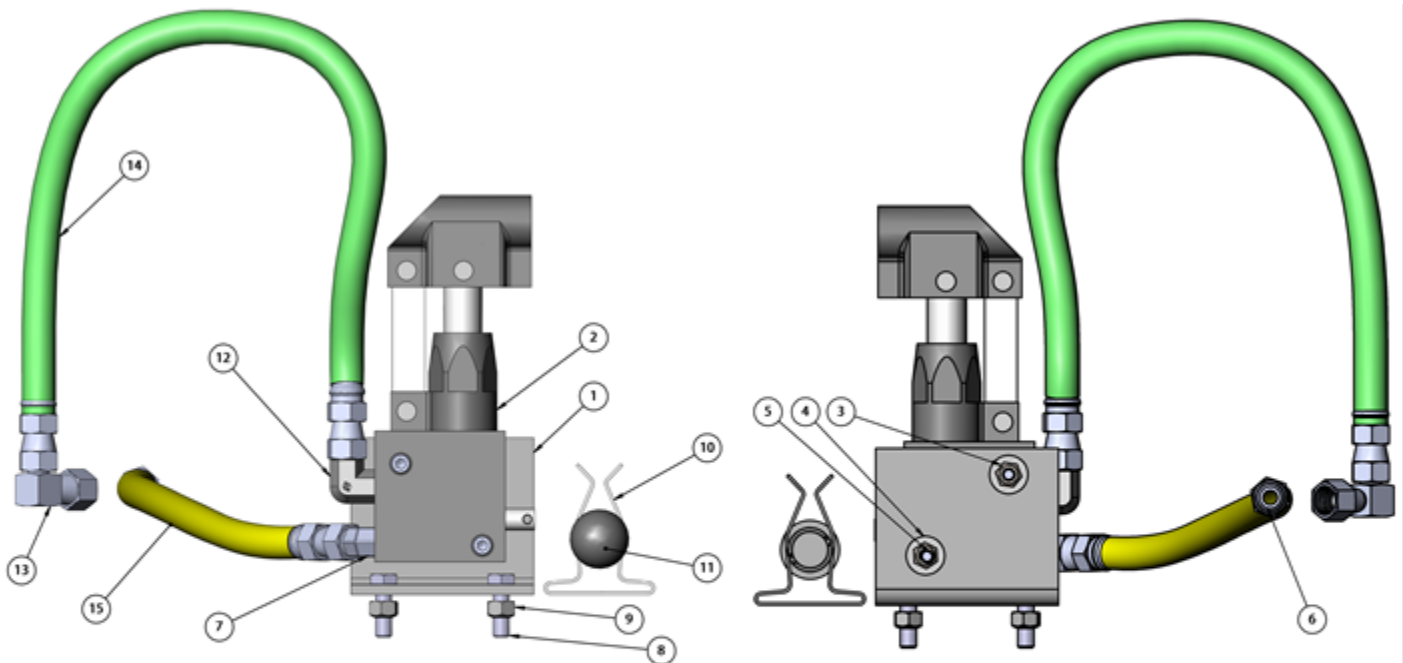

15	1	AT-501-292-020	HYDRAGUC LINE ASSY				
14	1	AT-501-354-014	HYDRAGUC LINE ASSY 3/8 DIA				
13	1	P34051	90 DEG ELBOW				
12	1	P34127	1/4-18 NPT M - 9/16-18 JIC M				
11	REF	P33922A	Handle				
10	2	P46192	TOOL HOLDER (HANDLE MTO BRACKET)				
9	2	P23510	5/16-18 HEX LOCK NUT				
8	2	P10040	JHCS 5/16-18 X 1" PLATED GRADE 2				
7	1	P34245	45 DEGREE ELBOW FROM 1/4-18 NPT MALE TO 9/16-18 JIC MALE				
6	1	P34006	ADAPTER 1/4 MALE NPT TO 9/16 MALE 37 DEG				
5	2	P15541	SOCKET HEAD CAP SCREW 1/4-20 X 2"				
4	2	P24001	1/4 DIA FLAT WASHER				
3	2	P23502	LOCK NUT	1/4-20			
2	1	P33902	HAND PUMP WITH HANDLE				
1	1	AP-501-267	HAND PUMP MTO BRACKET				
ITEM NO.	QTY.	PART NUMBER	DESCRIPTION	MATERIAL	MATERIAL SIZE	REMARKS	WGT.

BASIC ELECTRICS – REPLACEMENT PARTS

MONARCH W/POTTED SWITCHES

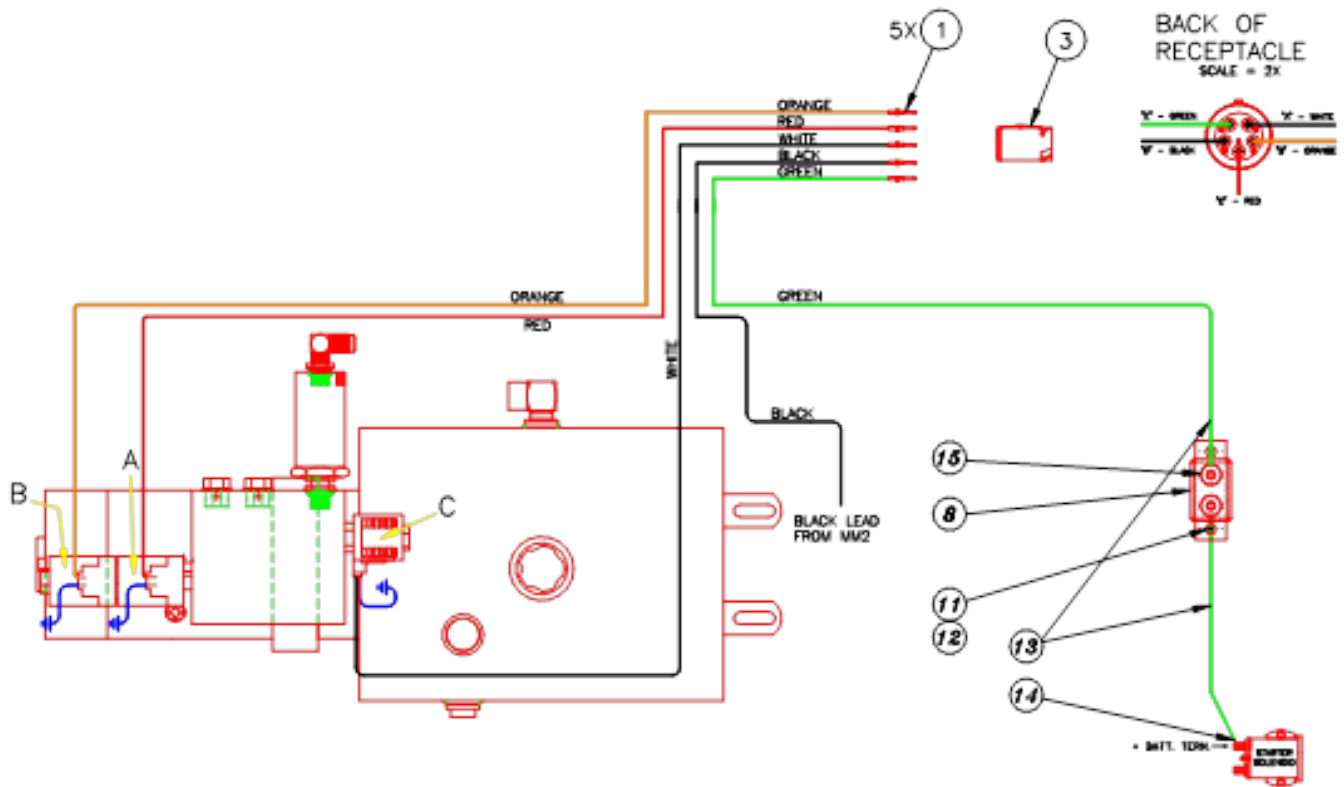

15	2	P46507	RING TERMINAL SM.		16-14, #10 SCR.	
14	1	P46751	RING TERMINAL		16-14, 3/8 SCR.	
13	2	P46301	GREEN 16 GA. WIRE		1 PC 22", 1 PC 13"	
12	2	P23504	NUT			
11	2	P19501	SCREW 10-24 X 1/2			
10	1	P17518	SELF TAPPING SCREW			
9	6	P46335	CABLE TIE, 7"		INSIDE ENCLOSURE	
8	1	P46236	20 AMP. CIR. BREAKER			
7	1	P46250	LOOM CLAMP 1/2"		FOR GROUND CABLE	
6	1	P46251	LOOM CLAMP 3/4"		FOR 16-5 CABLE	
5	1	S350-001.000	HR ROUND PLUG		3/16 DIA. X 1" LG.	
4	1	P46738	CORD GRIP 16MM x 1.5		FOR 10 GA WIRE	
3	1	P46886	RECEPTACLE		HD14-5-16P	
2	1	P46445	CORD GRIP 1/2 NPT		FOR 16-5 & 1/0 CABLE	
1	5	P46888	PIN, SOLID		0460-215-16141	
INDEX NO.	REQD.	PART NO.	PART NAME	MATL.	MATERIAL SIZE	REMARKS

SECTION F-F
SCALE 1 : 1.5

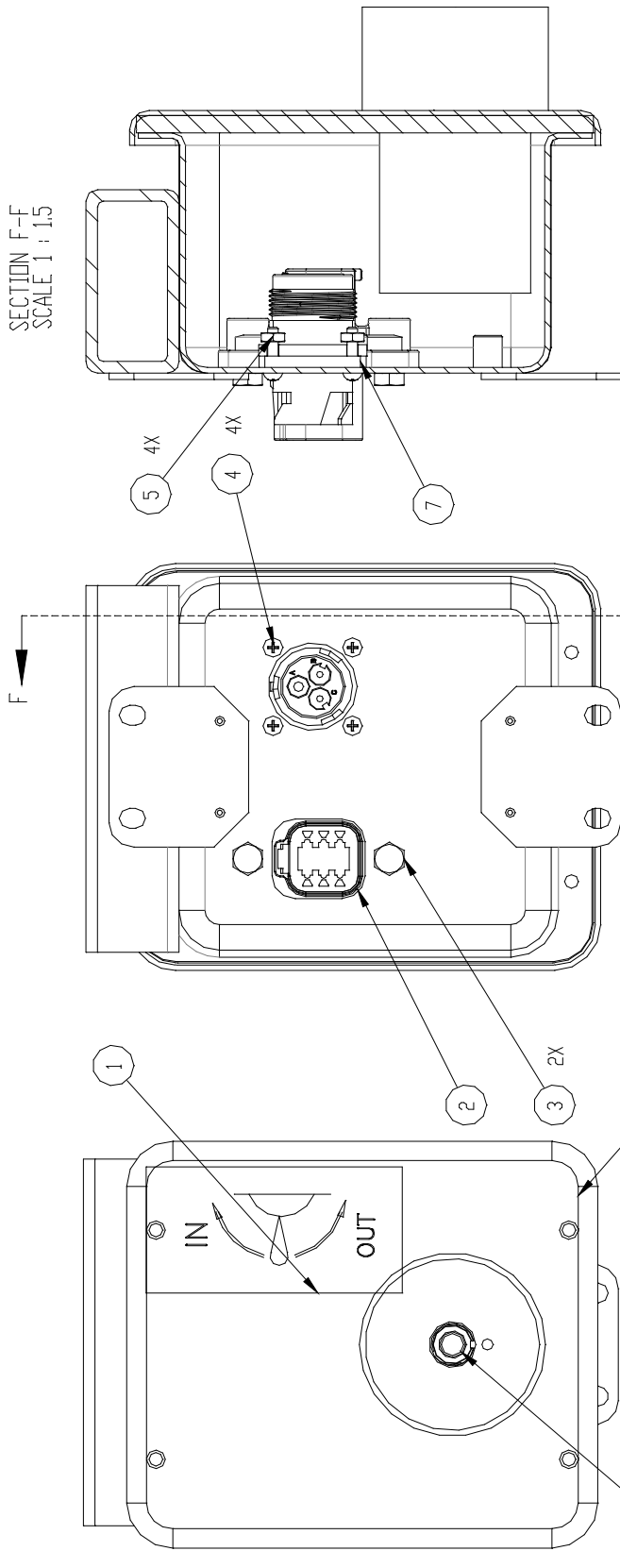

NOTE:
ITEM 3 MUST BE TORQUED AT 19+/-2 IN-LB
ITEM 4 SHOULD BE SNUG TIGHT

ITEM NO.	QTY.	PART NUMBER	DESCRIPTION	MATERIAL	MATERIAL SIZE	REMARKS	WGT.
9	1	P46291	HALF BOOT				
8	1	P55317	DO NOT OPEN DECAL				
7	1	P46901	3 PIN RECEPTACLE GASKET, HD10-3-GKT				
6	1	BA-551-780	SWITCH BOX WELDMENT / ASSY				
5	4	P23547	4-40 ZINC PLATED MACHINE NUT				
4	4	P19537	ROUND HEAD MACHINE SCREW 4-40 X 1/2				
3	2	P10816	HHCS M5 X 08 X 12				
2	1	BA-551-778	IN/OUT SWITCH ASSY W/ DESUTCH CONNECTORS				
1	1	P55222	IN/OUT TOGGLE SWITCH DECAL				

TOGGLE SWITCH REPLACEMENT PARTS

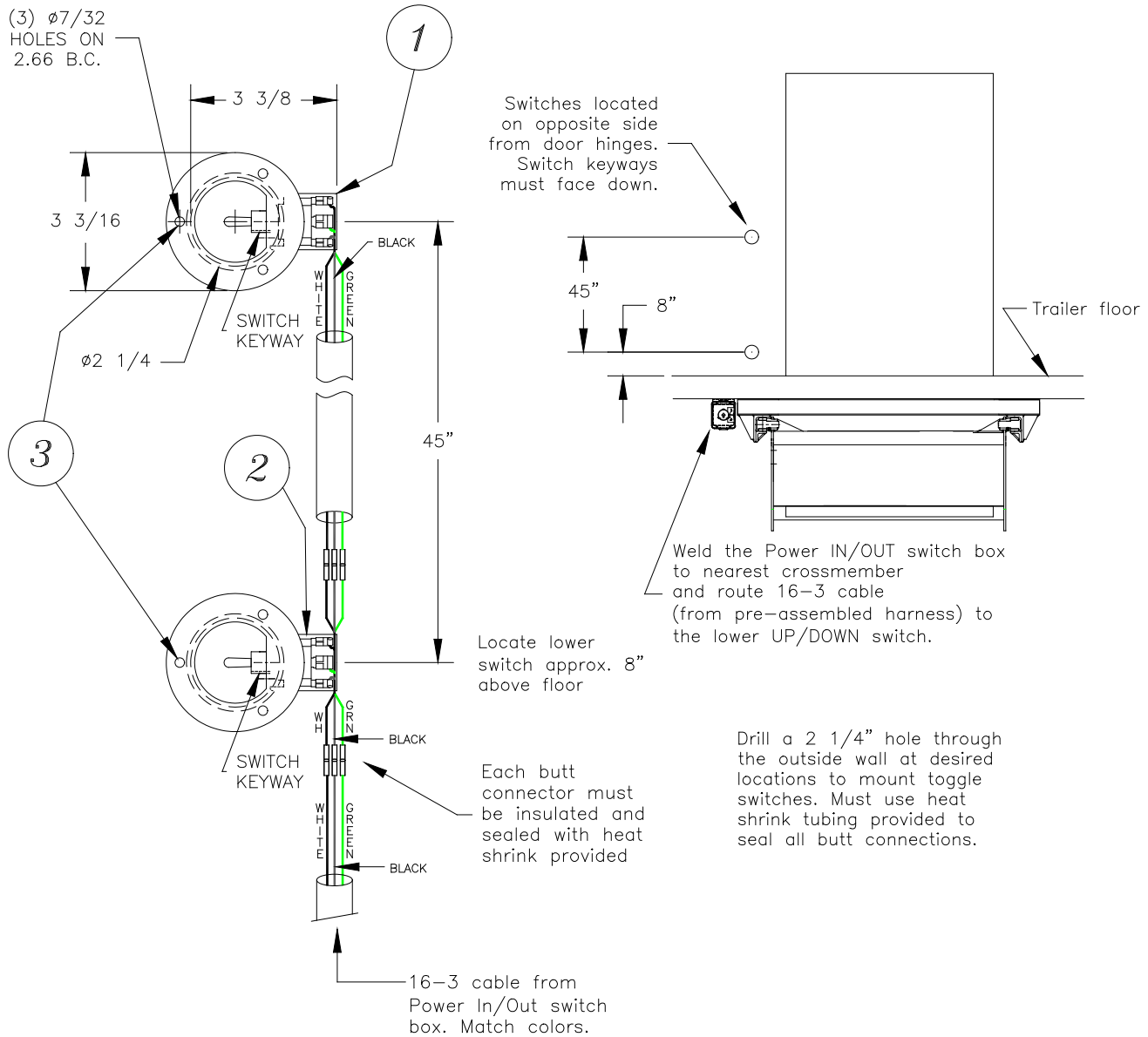

Index No.	Req'd	Part Number	Description	Comments
1	1	AA-551-538	TOP UP/DOWN SWITCH ASSY	Incl. Recess Sw. Plate
2	1	P46729	LOWER UP/DOWN SWITCH	Incl. Recess Sw. Plate
3	6	P17536	SHEET METAL SCREW	
4	4	P46250	LOOM CLAMP	NOT SHOWN
5	4	P17518	SELF TAPPING SCREW	NOT SHOWN
	2	P46292	RECESSED SW. PLATE	Ref. Items 1 & 2
	2	P46291	RUBBER HALF BOOT	Ref. Items 1 & 2

Walk Around Electrics (Option #183TLS-DEUTSCH)

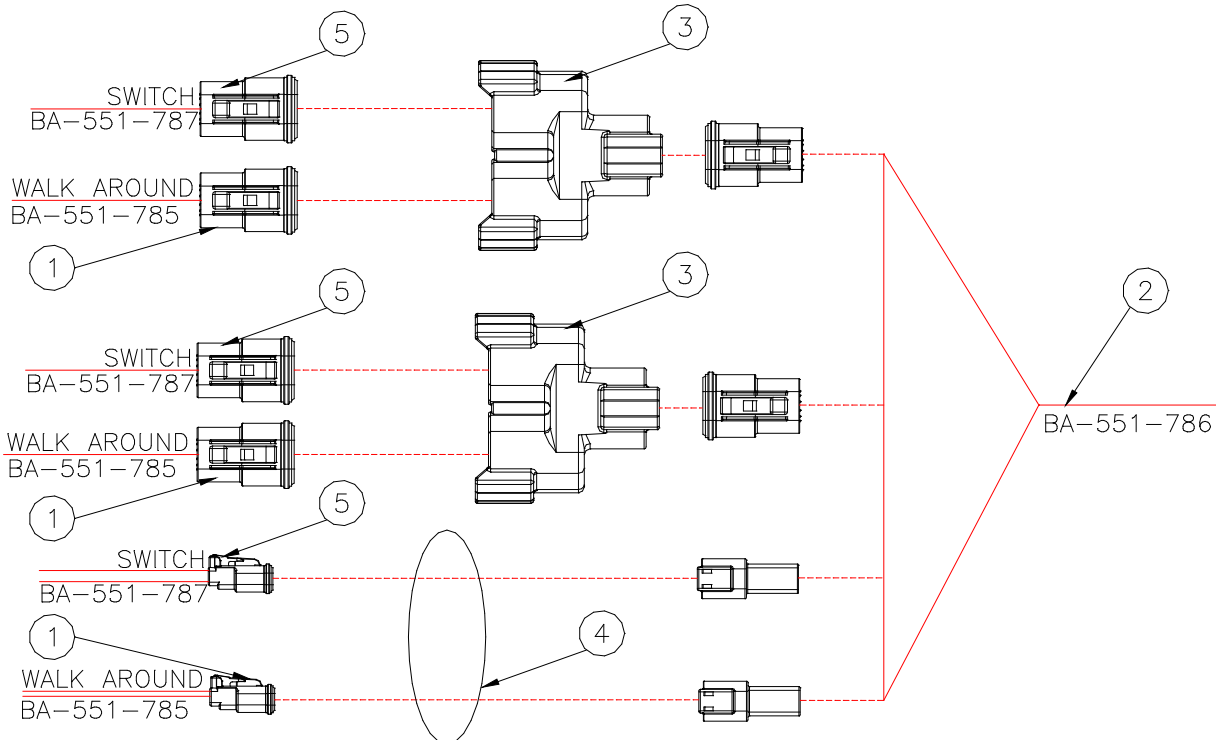
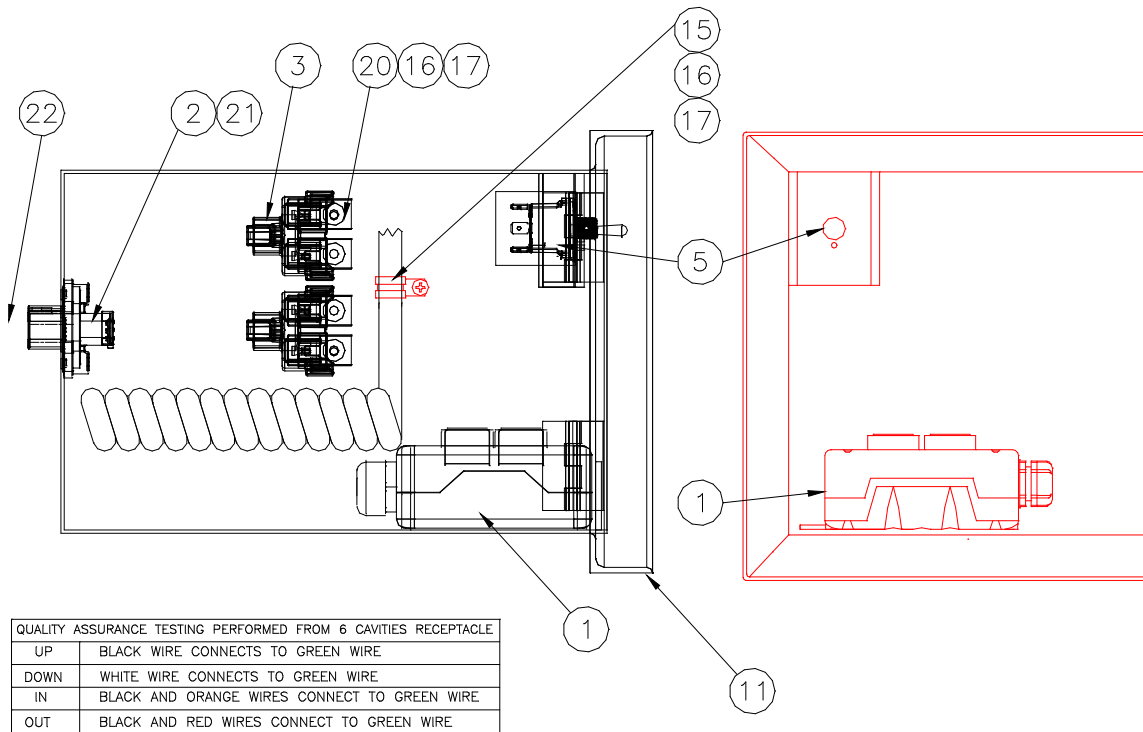

Walk Around Electrics (Option #183TLS-DEUTSCH)

22	1	BA-551-784	EXTERNAL SIDE WALL HARNESS FOR HAND HELD CONTROL			SHIP LOOSE
21	2	P10816	HHCS M5 X 0.8 X 12		TORQUED AT 19+/-2 IN-LB	
20	4	P46914	MOUNTING CLIP		1011-026-0205	
19	1	S050-006.000	BRACE	HR FLAT	1/4 X 1/2 X 6	
18	1	S560-014.000	SUPPORT ANGLE	ST ANGLE	1-1/2 X 1-1/2 X 1/4 X 14	
17	5	P23504	LOCK NUT		#10-24	
16	5	P19501	ROUND HEAD SCREW		#10-24 X 1/2	
15	6	P46450	LOOM CLAMP			SHIP 5 LOOSE
14	5	P17518	SELF TAPPING SCREW			SHIP LOOSE
13						
12						
11	1	P46915	PUSH BUTTON BOX		REF. DWG . CA-551-789	
10						
9						
8						
7						
6						
5	1	P46912	POTTED TOGGLE SWITCH ASSY			
4	1	P46335	CABLE TIE BLACK NYLON			
3	2	P46913	RECEPTACLE Y CONNECTOR			
2	1	BA-551-786	WALK AROUND STORAGE BOX - INSIDE HARNESS			
1	1	BA-551-785	2 BUTTON CONTROL ASSY.			
INDEX NO.	REQD.	PART NO.	PART NAME	MATL.	MATERIAL SIZE	REMARKS

REPLACEMENT OF SAFETY DECALS

Leyman Manufacturing will replace safety stickers at any time **FREE OF CHARGE**.

Locate the following decals on trailer side wall near door –

- P55236** Operating Instructions
- P55157** Urgent Warning – Read Before Operation (Qty. 2)
- P55294** CAUTION Do Not Stand....
- P55442** Maximum Capacity Decal - LPS

Locate the following decal on trailer side wall under door threshold –

- P55138** Keep Feet from Edge....

Locate the following decals at Toggle Switches –

- P55222** IN / OUT
- P55221** UP / DOWN (Qty. 2)



