



Lift Gate Product Catalog **2026**



# INDEX

## Extreme Duty Column Gates

<b>FREEDOM FXD</b> .....	4
--------------------------	---

## Hide-Away Side Gates

<b>PREMIER LPS</b> .....	7
<b>TRIUMPH LTS</b> .....	9
<b>LEGEND TLS</b> .....	11
<b>SUPERIOR TSG</b> .....	12

## Hide-Away Tuck Under Gates

<b>HERO LHP</b> .....	14
<b>LIBERTY SLP</b> .....	16

## Hide-Away Rear Gates

<b>PATRIOT LPR</b> .....	19
--------------------------	----

## Private Use Lift Gate

<b>GUARDIAN PLG</b> .....	22
---------------------------	----

## Internal Elevator Lift Gates

<b>VALOR</b> Ley-Vador .....	24
------------------------------	----



# EXTREME DUTY COLUMN LIFT GATE



# LEYMAN

## LIFT GATES

# FREEDOM FXD

Extreme Duty Column Gate



**LIFTING CAPACITY 4,500 to 6,800 lbs. The Heaviest Load Capacity in the Industry**

Floor Heights: 40" Laden/56" Unladen

<b>FREEDOM FXD Standard Features</b>	<b>Benefits</b>
True Level Ride Lift Gate	Provides a Safer Working Environment for Driver and Freight
Dual Power Unit	Designed to Reduce Road Calls
Power Down on Demand	Offers Options to Lower Platform
Hose Burst Valves	A Safety Feature that Prevents Sudden Platform Fall
Marine Potted Switches	Watertight Switches – Reduces Electrical Failure
Static Wire Position Within Gate Mast	Stationary Wire Reduces Wire Breakage and Electrical Failure
Lower Hydraulic Pressures	Reduces Wear on Hydraulic System
Circuit Breaker for All Power Kit Options	Protects from Electrical Circuit Damage Caused by Current Overload
Power Unit Safety Cut-Off Switch	Quick Power Shut-Off Designed to Reduce Injuries
Steel Rollers with Greasable Anti-Friction Bearings	Extends Roller Life
L.E.D. Lights (Stop, Turn, and Tail Lights)	More Visibility Using Less Energy
Power Close Platform	Ease of Operation
Smooth Outer Rails with Reinforced Plates	For Added Strength and Reliability
Pressure Compensated Flow Control	Steady Hydraulic Pressure for Smooth Operation

### FREEDOM FXD Technical Specs

Model Number	Lifting Capacity	Platform Size	Main Platform	Secondary Platform	Ramp	Approx. Weight (Steel Platform)	Approx. Weight (Aluminum Platform)
FXD 45	4,500 lbs.	86" W x 60" D	36" D	24" D	12" Fixed Taper	FXD 45 1,680 lbs.	FXD 45AL 1,460 lbs.
		86" W x 72" D	42" D	30" D	12" Fixed Taper	FXD 45 1,750 lbs.	FXD 45AL 1,500 lbs.
		86" W x 72" D	36" D	36" D	None	FXD 45 1,850 lbs.	FXD 45AL 1,500 lbs.
		86" W x 84" D	42" D	42" D	None	FXD 45 1,850 lbs.	FXD 45AL 1,525 lbs.
FXD 55	5,500 lbs.	86" W x 60" D	36" D	24" D	12" Fixed Taper	FXD 55 1,850 lbs.	FXD 55AL 1,550 lbs.
		86" W x 72" D	42" D	30" D	12" Fixed Taper	FXD 55 1,900 lbs.	FXD 55AL 1,575 lbs.
		86" W x 72" D	36" D	36" D	None	FXD 55 1,900 lbs.	FXD 55AL 1,575 lbs.
		86" W x 84" D	42" D	42" D	None	FXD 55 2,000 lbs.	FXD 55AL 1,600 lbs.
FXD 68	6,800 lbs.	86" W x 60" D	36" D	24" D	12" Fixed Taper	FXD 68 1,900 lbs.	FXD 68AL 1,600 lbs.
		86" W x 72" D	42" D	30" D	12" Fixed Taper	FXD 68 2,120 lbs.	FXD 68AL 1,770 lbs.
		86" W x 72" D	36" D	36" D	None	FXD 68 2,120 lbs.	FXD 68AL 1,770 lbs.
		86" W x 84" D	42" D	42" D	None	FXD 68 2,250 lbs.	FXD 68AL 1,825 lbs.

FREEDOM FXD Available Options	
OPTION #	OPTION DESCRIPTION
96	96" Wide Vehicle Kit with 80" Wide Platform
103FXD	Remote Walk Around Remote Control
104	Header Kit (Dock Seal)
104-HLK	Header Light Kit
108FXD	Single Foot Operated Ramp Cart Stop (Fixed Taper Only)
108FXD2P	Dual Foot Operated Ramp Cart Stop (Fixed Taper Only)
113	16" Aluminum Retention Ramp
113-SPL	16" Split Aluminum Retention Ramp (Steel Platform Only)
131-3PL	Plastic Battery Box w/Hold Down Straps (Holds 3 Batteries) and Circuit Breaker
151	Bolt-On Installation Kit
151-SS	Bolt-On Installation Kit – Stainless Steel
214	Maintenance Minder2
245	Hose Channel Kit
258	Gravity (Automatic) Cart Stop (Available on Steel Platform Only)
260	Clear Back Up Lights Kit for <b>FREEDOM FXD</b>
272FXD	Power Unit/Short Frame Option (Use for Limited Install Space). When Batteries are Needed Use With <b>132-3PL</b> – Plastic Battery Box w/Hold Down Straps (Holds 3 Batteries)
AL	Aluminum Platform
GV	Galvanized (Full Gate)
GVP	Galvanized (Platform Only)
P46622	AGM Battery

FREEDOM FXD Power Kits	
OPTION #	OPTION DESCRIPTION
123NG	Power Kit: 30' "2" Gauge Cable – NO Trailer Plug
136NG	Power Kit: 35' "2" Gauge Cable – NO Trailer Plug
257NG-30	Power Kit: 30' "2" Gauge Cable – Dual Pole with Combo Box (Dual/Single Pole Receptacles)
257NG-45	Power Kit: 45' "2" Gauge Cable – Dual Pole with Combo Box (Dual/Single Pole Receptacles)
257NG-60	Power Kit: 60' "2" Gauge Cable – Dual Pole with Combo Box (Dual/Single Pole Receptacles)





# HIDE-AWAY SIDE LIFT GATES



# LEYMAN

## LIFT GATES

# PREMIER LPS

Hide-A-Way® Trailer Side Gate



### LIFTING CAPACITY 4,500 – Designed to Reduce Road Calls

Floor Heights: 48" Laden/56" Unladen

<b>PREMIER LPS Standard Features</b>	<b>Benefits</b>
True Level Ride Lift Gate	Provides a Safer Working Environment for Driver and Freight
Galvanized Primary Platform, Aluminum secondary Platform & Retention Ramp	Prevents Rust
Power In and Out with Stainless Steel Chain	Designed to Reduce Road Calls
Flashing Safety Light on End of Platform	Safety Feature Provides Greater Visibility of Gate
Automatic Over-the-Road Lock	Safely Secures Lift Gate in Over-the-Road Position
Adjustable to Trailer Dimensions	Ensures Custom Fit for Side Lift Gate
Accommodates Curb or Street Side of Trailer Installation	Flexibility to Meet Your Specific Delivery Requirements
Power Pack Enclosure	Houses Hydraulic Pump and Room for up to Four (4) Batteries
Pressure Compensated Flow Control	Steady Hydraulic Pressure for Smooth Operation
Gravity Down	Reduces Power Usage and Motor Wear
Marine Potted Switches	Watertight Switches – Reduces Electrical Failure
Spring Assisted Opening and Closing	Ease of Use and Reduces Physical Effort to Operate

### PREMIER LPS Technical Specs

Model Number	Lifting Capacity	Platform Size		Primary Platform		Secondary Platform		Approx. Weight	Ramp	Vehicle Width
		W"	D"	W"	D"	W"	D"			
LPS 4500	4,500 lbs.	72"	68"	72"	51"	72"	17"	1,150 lbs	15" Deep Retention Single/Dual	96" and 102"
		80"	76"	80"	51"	80"	25"	1,400 lbs		
		86"	76"	86"	51"	86"	25"	1,750 lbs		
		86"	80"	86"	51"	86"	29"	1,775 lbs		

#### PREMIER LPS Available Options

OPTION #	DESCRIPTION
111	Additional Circuit Breaker for Supply Line
133	Conversion Kit For Mounting to Aluminum Cross Members
134	Mud Flap
142	Dual Power Unit
155	High Visibility Flashing Safety Lights along Lift Gate Arm, Nose Warning Light
214	Maintenance Minder2
261	Emergency Hand Pump
265	Power Unit Box Work Light
266 LPS-RG	Interior Mounted: Red/Green Safety Light at Trailer Door Power Unit Box Work Light
268	Collapsible Safety Hand Rails
270LPS-R1	1 Piece Retention Ramp Option for LPS
270LPS-R2	2 Piece Retention Ramp Option for LPS
271	Plug-In, Hand-Held Remote with Storage Box in Place of Upper Switch
275LPS	Power Down On Demand
BA-551-897	Slider Gate Switch Tester
BA-551-900	Back-Up Walk-Around Remote
CA-551-913	Red Nose Warning Lights
GV	Galvanized (Full Gate)
P46622	AGM Battery

#### PREMIER LPS Power Kits

OPTION #	OPTION DESCRIPTION
121LPS	Power Kit: 45' "2" Gauge Cable and Trailer Plug NOT Included
136LPS	Power Kit: 35' "2" Gauge Cable and Trailer Plug NOT Included
257NG-45	Power Kit: 45' "2" Gauge Cable – Dual Pole w/Combo Box (Dual/Single Pole Receptacles)
257NG-30	Power Kit: 30' "2" Gauge Cable – Dual Pole w/ Combo Box (Dual/Single Pole Receptacles)
257NG-45	Power Kit: 45' "2" Gauge Cable – Dual Pole w/Combo Box (Dual/Single Pole Receptacles)
257NG-60	Power Kit: 60' "2" Gauge Cable – Dual Pole w/Combo Box (Dual/Single Pole Receptacles)
269-2B	Battery Hold-Down Kit - 2 Batteries for 42, 48, 60, 72, 80 Gate Width
269-3B	Battery Hold-Down Kit - 3 Batteries for 60, 72, 80 Gate Width
269-4B	Battery Hold-Down Kit - 4 Batteries for 72, 80 Gate Width

#### PREMIER LPS Minimum Mounting Space Requirements

PLATFORM WIDTH	DIMENSION "X"
72"	90"
80"	98"
86"	104"

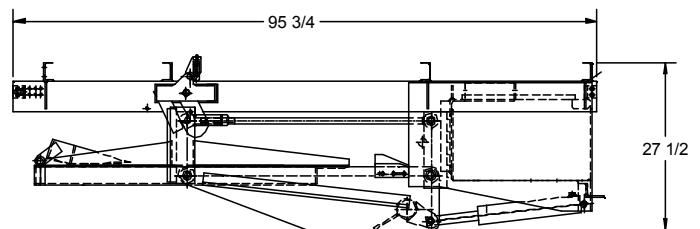
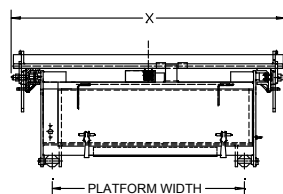

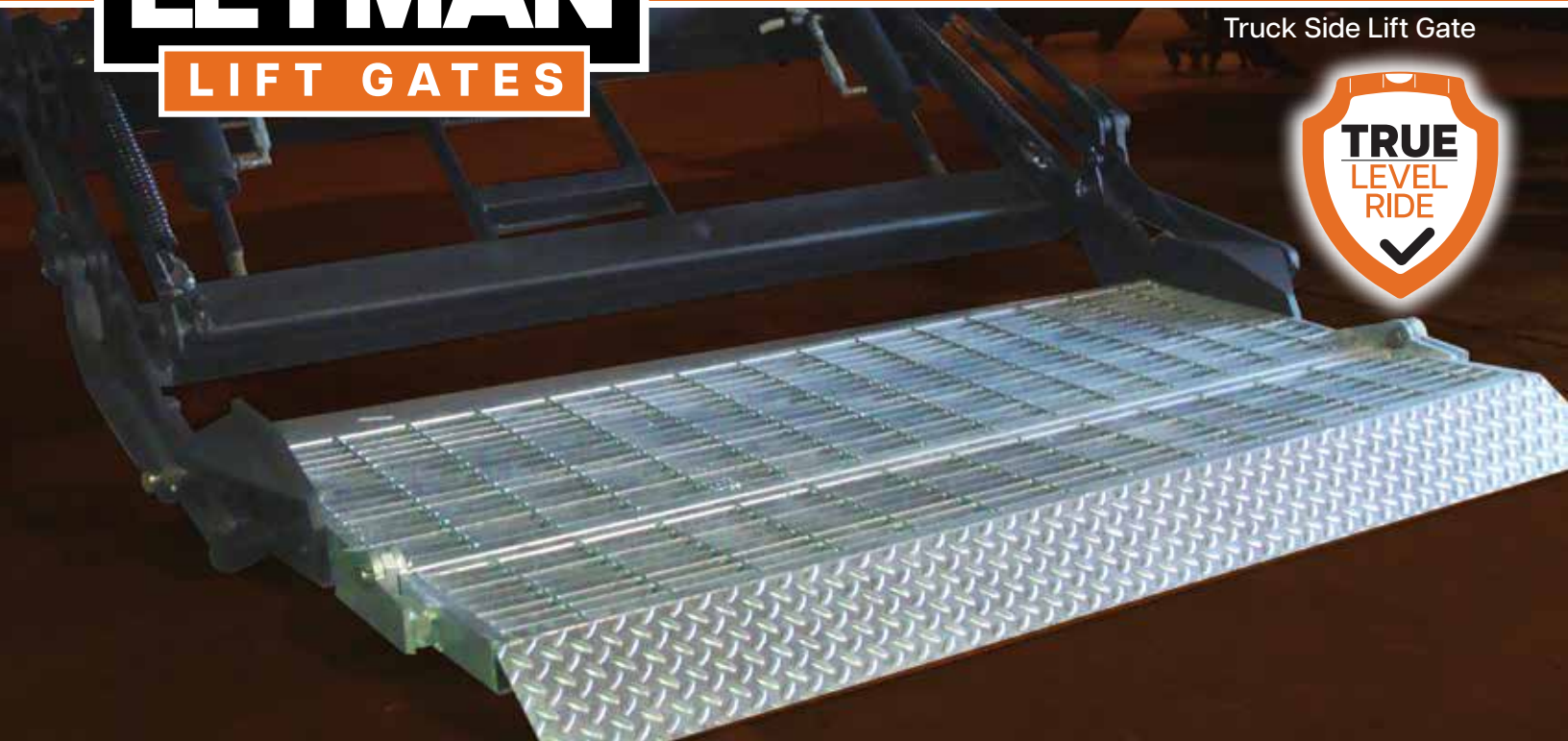

### LIFTING CAPACITY 2,000 – Truck Side Door Level Ride Platform

Floor Heights: 45" Laden/56" Unladen

Model Number	Lifting Capacity	Platform Size		Approx. Weight	Ramp
		W"	D"		
<b>Triumph™ LTS 2000</b>	2,000 lbs.	60"	32"	825 lbs	10" Taper

<b>TRIUMPH™ LTS Standard Features</b>	<b>Benefits</b>
True Level Ride Lift Gate	Provides a Safer Working Environment for Driver and Freight
Bar Grated Galvanized Steel Platform	Added Traction and Prevents Rust
Built-In Adjustable Step	Adaptable to Drivers Comfort
Standard Locking Valves	A Safety Feature that Aids Platform Stability
Power Pack Enclosure	Houses Pump and Motor
Marine Potted Switches	Watertight Switches – Reduces Electrical Failure
Spring Assisted Opening and Closing	Ease of Use and Reduces Physical Effort to Operate
Grease Fittings at Pivot Points	Reduces Friction, Increases Lifespan

<b>TRIUMPH™ LTS Available Options</b>	
OPTION #	DESCRIPTION
111	Additional Circuit Breaker for Supply Line
143	Safety Cut Off Switch
214	Maintenance Minder2
P46622	AGM Battery

<b>TRIUMPH™ LTS Power Kits</b>	
OPTION #	POWER OPTION DESCRIPTION
125-NG	Power Kit: 27" "2" Gauge Cable – NO Trailer Plug



**LIFTING CAPACITY 3,500 to 4,500 – Installs without Cutting Up to 10"**

Floor Heights: 48" Laden/58" Unladen

LEGEND TLS Standard Features	Benefits
True Level Ride Lift Gate	Provides a Safer Working Environment for Driver and Freight
Power In and Out with Stainless Steel Chain	Designed to Reduce Road Calls
Automatic Over-the-Road Lock	Safely Secures Lift Gate in Over-the-Road Position
Adjustable to Trailer Dimensions	Ensures Custom Fit for Side Lift Gate
Accommodates Curb or Street Side of Trailer Installation	Flexibility to Meet Your Specific Delivery Requirements
Power Pack Enclosure	House Hydraulic Pump and Room for Up to Four (4) Batteries*
Pressure Compensated Flow Control	Steady Hydraulic Pressure for Smooth Operation
Gravity Down	Reduces Power Usage and Hydraulic Pump Wear
Marine Potted Switches	Watertight Switches – Reduces Electrical Failure

\* Based on Gate Width

### LEGEND TLS Technical Specs

Model Number	Lifting Capacity	Platform Size	Main Platform	Secondary Platform	Rigid Ramp	Approx. Weight
TLS 3510	3,500 lbs.	42" W x 55" D	51" D	4" D	10" Taper	TLS 3510 1,200 lbs.
		48" W x 55" D				TLS 3510 1,300 lbs.
		60" W x 55" D				TLS 3510 1,450 lbs.
		72" W x 55" D				TLS 3510 1,600 lbs.
TLS 3510	3,500 lbs.	80" W x 48" D	48" Flat	No Secondary	5" Taper	TLS 3510 1,800 lbs.
TLS 4510	4,500 lbs.	42" W x 55" D	51" D	4" D	10" Taper	TLS 4510 1,250 lbs.
		48" W x 55" D				TLS 4510 1,350 lbs.
		60" W x 55" D				TLS 4510 1,500 lbs.
		72" W x 55" D				TLS 4510 1,660 lbs.

### LEGEND TLS Available Options

OPTION #	DESCRIPTION
111	Additional Circuit Breaker for Supply Line
133	Conversion Kit For Mounting to Aluminum Cross Members
134	Mud Flap
142	Dual Power Unit
154	Reflecting Tape
155	High Visibility Flashing Safety Lights along Lift Gate Arm, Nose Warning Light
214	Maintenance Minder2
261	Emergency Hand Pump
265	Power Unit Box Work Light
268	Collapsible Safety Hand Rails (60" Minimum Width)
271	Plug-In, Hand-Held Remote with Storage Box in Place of Upper Switch
BA-551-897	Switch Harness Tester
BA-551-900	Backup Hand-held Remote
GV	Galvanized (Full Gate)
GVP	Galvanized (Platform Only)
P46622	AGM Battery

### LEGEND TLS Power Kits

OPTION #	OPTION DESCRIPTION
257NG-30	Power Kit: 30' "2" Gauge Cable – Dual Pole with Combo Box (Dual/Single Pole Receptacles)
257NG-45	Power Kit: 45' "2" Gauge Cable – Dual Pole with Combo Box (Dual/Single Pole Receptacles)
257NG-60	Power Kit: 60' "2" Gauge Cable – Dual Pole with Combo Box (Dual/Single Pole Receptacles)
269-2B	Battery Hold-Down Kit - 2 Batteries for 42, 48, 60, 72, 80 Gate Width
269-3B	Battery Hold-Down Kit - 3 Batteries for 60, 72, 80 Gate Width
269-4B	Battery Hold-Down Kit - 4 Batteries for 72, 80 Gate Width





# SUPERIOR™ TSG

Hide-A-Way® Truck Side Lift Gate



**LIFTING CAPACITY 3,000 lbs. Built to Last for Reduced Road Calls**  
 Floor Heights: 44" Laden/56" Unladen

## SUPERIOR™ TSG Technical Specs

Model Number	Lifting Capacity	Platform Size	Main Platform	Secondary Platform	Approx. Weight
Superior™ TSG 3000	3,000 lbs.	54" W x 34" D	23" D	11" D	TSG 3000 800 lbs.
		72" W x 34" D			TSG 3000 830 lbs.

SUPERIOR™ TSG Standard Features	Benefits
True Level Ride Lift Gate	Provides a Safer Working Environment for Driver and Freight
Manual Transit Lock	Safely Secures Lift Gate in Over-the-Road Position
Power Pack Enclosure	Houses Hydraulic Pump
Marine Potted Switches	Watertight Switches – Reduces Electrical Failure
Spring Assisted Opening and Closing	Ease of Use and Reduces Physical Effort to Operate
Greaseless Bushings	Reduces Maintenance Costs

### SUPERIOR™ TSG Available Options

OPTION #	DESCRIPTION
111	Additional Circuit Breaker for Supply Line
143	Safety Cut Off Switch (In Cab)
201	Handheld Remote, Plugs into Receptacle
212	Drivers Step
213	12" Retention Ramp (Steel)
214	Maintenance Minder2

### SUPERIOR™ TSG Available Options - cont.

OPTION #	DESCRIPTION
GV	Galvanized (Full Gate)

### SUPERIOR™ TSG Power Kits

OPTION #	POWER OPTION DESCRIPTION
125-NG	Power Kit: 27" "2" Gauge Cable – NO Trailer Plug

05/26



**HIDE-AWAY TUCK UNDER  
LIFT GATES**



### LIFTING CAPACITY UP to 5,500 lbs. Built to Last for Reduced Road Calls

Floor Heights: 2500/3500 – 46" Laden/59" Unladen

Floor Heights: 4500/5500 – 48" Laden/60" Unladen

HERO LHLP Standard Features	Benefits
Level Ride Lift Gate	Provides a Level Working Environment for Driver and Freight
Power Down On Demand	Offers Options to Lower Platform (LHLP4500/LHLP5500 Only)
Aluminum Platform	Inhibits Rust While Reducing Weight
Foot Operated Cart Stops x 2	Increases Safety by Reducing Accidents
Low P.S.I. Due to Larger Piston Area	Creates Lower Pressure, Reduces Wear and Extends Hydraulic Pump Life
Adjusts to Different Chassis Widths	Allows Flexibility of Vehicle Installation Options
Pressure Compensated Flow Control	Steady Hydraulic Pressure for Smooth Operation
Bolt-On Power Pack Enclosure Hydraulic Pump	Easy Installation and Protection from Moisture
Marine Potted Switches	Watertight Switches – Reduces Electrical Failure
Spring Assisted Opening and Closing	Ease of Use and Reduces Physical Effort to Operate

### HERO LHLP Technical Specs

Model Number	Vehicle Width	Lifting Capacity	Platform Size		Approx. Weight
			W"	D"	
LHLP 5500G	96" 102"	5,500 lbs.	86"	60"	1,150 lbs
LHLP 4500G		4,500 lbs.			1,000 lbs
LHLP 3500G		3,500 lbs.	80"		795 lbs
LHLP 2500G		2,500 lbs.			770 lbs

### HERO LHLP Power Kits

OPTION #	OPTION DESCRIPTION
123-NG	Power Kit: 30' "2" Gauge Cable – NO Trailer Plug
136-NG	Power Kit: 35' "2" Gauge Cable – NO Trailer Plug
257NG-30	Power Kit: 30' "2" Gauge Cable – Dual Pole with Combo Box (Dual/Single Pole Receptacles)
257NG-45	Power Kit: 45' "2" Gauge Cable – Dual Pole with Combo Box (Dual/Single Pole Receptacles)
257NG-60	Power Kit: 60' "2" Gauge Cable – Dual Pole with Combo Box (Dual/Single Pole Receptacles)

### HERO LHLP Available Options

OPTION #	DESCRIPTION
103	Handheld Remote, Plugs Into Receptacle
107	Emergency Hand Pump
111	Additional Circuit Breaker for Supply Line for LHLP23/35 (Standard on LHLP45/55)
117LHLPLED	LED 4 Light Kit with Surface Mount Boxes
132-3PL	Plastic Battery Box w/Hold Down Straps (Holds 3 Batteries)
143	Safety Cut Off Switch
145	6" Rubber Dock Bumpers
145-12	12" Rubber Dock Bumpers
188	Trailer Mounting System
194	Threshold Mounting Tube
214	Maintenance Minder2
215	96" Floor Extension
215 BOLT-ON	96" Bolt-On Floor Extension
216	102" Floor Extension
216 BOLT-ON	102" Bolt-On Floor Extension
219	86" Wide Platform (LHLP 2500G/3500G)
229	D.O.T. Approved Bumper
233	Step with Threshold Tube
233LHLP	Heavy Duty Steps (Non-Adjustable)
233LHLP ADJ	Heavy Duty Steps (Adjustable)
233LHLP ADJ-FLEX	Heavy Duty Wire Rope Steps
GV	Galvanized Full Gate

05/26





# LIBERTY SLP

Tuckunder Rear Lift Gate



## LIFTING CAPACITY 3,500 – Steel Wedge Tuckunder Lift Gate

Floor Heights: 3500W 44" Laden/56" Unladen

Floor Heights: 3500WLB 36" Laden/46" Unladen

LIBERTY SLP Standard Features	Benefits
1" Solid Steel Lifting Arms	Heavy-Duty and Built to Last
Low P.S.I Due to Larger Piston Area	Lower Pressure Reduces Wear, Extends Hydraulic Pump Life
Manual Transit Lock	Safely Secures Lift Gate in Over-the-Road Position
Pressure Compensated Flow Control	Steady Hydraulic Pressure for Smooth Operation
Bolt-On Power Pack Enclosure Holds Hydraulic Pump	Easy Installation
Marine Potted Switches	Watertight Switches – Reduces Electrical Failure
Spring Assisted Opening and Closing	Ease of Use and Reduces Physical Effort to Operate
Greaseless Bushings	Reduces Maintenance Costs



### LIBERTY SLP Technical Specs

Model Number	Lifting Capacity	Platform Size		Primary Platform	Secondary Platform	Approx. Weight	Vehicle Width	Vehicle Height
		W"	D"	D"	D"			
<b>SLP 3500W</b>	3,500 lbs.	80"	52"	27"	25"	975 lbs	96" / 102"	44" Laden to 56" Unladen
<b>SLP 3500WLB</b>	3,500 lbs.	80"	50"	25"	25"	975 lbs	96" / 102"	36" Laden to 46" Unladen

### LIBERTY SLP Available Options

OPTION #	DESCRIPTION
111	Additional Circuit Breaker for Supply Line
132-3PL	Plastic Battery Box with Hold Down Straps (Holds Three Batteries)
143	Safety Cut Off Switch
145	6" Rubber Dock Bumpers
145-12	12" Rubber Dock Bumpers
158	Power down for Hide-A-Way®
169	D.O.T. Approved Bumper
188	Trailer Mounting System
201	Hand Held Remote Control, Plugs into Receptacle
214	Maintenance Minder2
215	96" Floor Extension
216	102" Floor Extension
225	Threshold Mounting Tube
233	Heavy Duty Steps
243SLP96	BOLT-ON 96" Bolt-on Floor Extension
243SLP102	BOLT-ON 102" Bolt-on Floor Extension

### LIBERTY SLP Available Options – Cont.

OPTION #	DESCRIPTION
CA-800-545	Cart Stop
GV	Galvanized (Full Platform)
GV-P	Galvanized (Platform Only)
P46622	AGM Battery

### LIBERTY SLP Power Kits

OPTION #	OPTION DESCRIPTION
123-NG	Power Kit: 30' "2" Gauge Cable – NO Trailer Plug
136-NG	Power Kit: 35' "2" Gauge Cable – NO Trailer Plug
257NG-30	Power Kit: 30' "2" Gauge Cable – Dual Pole with Combo Box (Dual/Single Pole Receptacles)
257NG-45	Power Kit: 45' "2" Gauge Cable – Dual Pole with Combo Box (Dual/Single Pole Receptacles)
257NG-60	Power Kit: 60' "2" Gauge Cable – Dual Pole with Combo Box (Dual/Single Pole Receptacles)



**HIDE-AWAY REAR  
LIFT GATE**



### LIFTING CAPACITY 4,500 – Installs Without Cutting Up to 10"

Floor Heights: \* Laden/58" Unladen

\*Floor height is a function of trailer construction. Contact Leyman for correct Laden height for your trailer.

PATRIOT LPR Standard Features	Benefits
True Level Ride Lift Gate	Provides a Safer Working Environment for Driver and Freight
Power In and Out with Stainless Steel Chain	Designed to Reduce Road Calls
Adjustable Guides (In/Out – Side/Side Functions)	Ensures Optimal Fit and Performance
Pressure Compensated Flow Control	Steady Hydraulic Pressure for Smooth Operation
Greaseless Bushings and Rollers	Reduces Maintenance Costs
Flashing Safety Lights	Increases Visibility
Power Pack Enclosure	Houses Hydraulic Pump and Room for Up to Four (4) Batteries
Primary Platform at Stored Position Creates DOT Bumper	Meets D.O.T. Requirements For U.S. and Canada
Gravity Down	Reduces Power Usage and Hydraulic Pump Wear
Marine Potted Switches	Watertight Switches – Reduces Electrical Failure
Spring Assisted Opening and Closing	Ease of Use and Reduces Physical Effort to Operate

### PATRIOT LPR Technical Specs

Model Number	Lifting Capacity	Platform Size	Main Platform	Secondary Platform	Ramp	Vehicle Width	Approx. Weight
LPR 4500	4,500 lbs.	80" W x 72" D	32" D Steel	40" D Aluminum	16" Retention	102"	1,825 lbs.

### PATRIOT LPR Available Options

OPTION #	DESCRIPTION
103	Handheld Remote, Plugs into Receptacle
111	Additional Circuit Breaker for Supply Line
113LPRCURBSIDE	28" W x 20" D Aluminum Retention Ramp Curbside
133	Conversion Kit For Mounting to Aluminum Cross Members
134	Mud Flap
154	Reflecting Tape
184	Emergency Hand Pump
214	Maintenance Minder2
BA-551-897	Slider Gate Switch Tester
BA-551-900	Back-Up Walk-Around Remote
GV	Galvanized (Full Gate)
P46622	AGM Battery

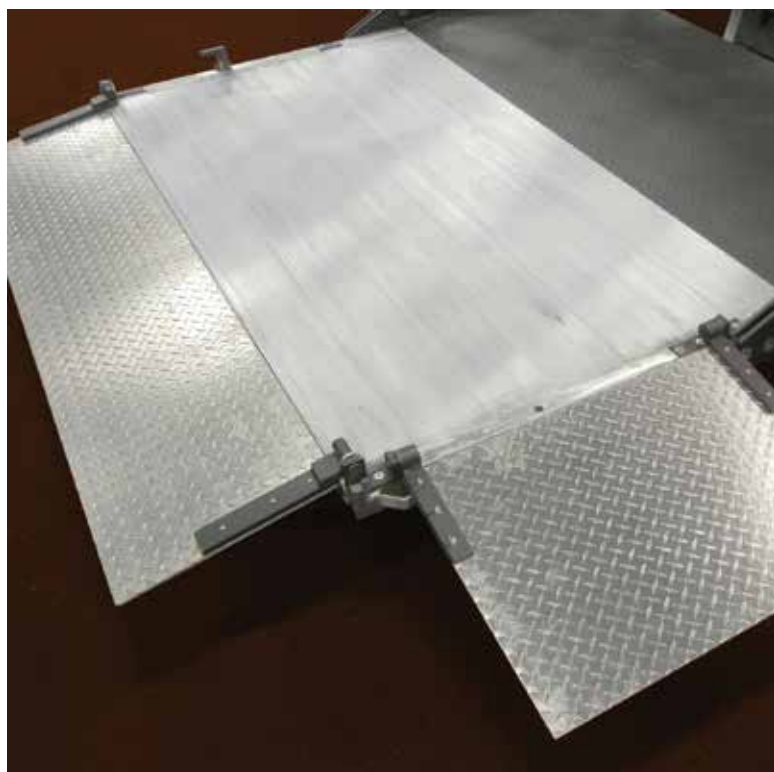

### PATRIOT LPR Power Kits

OPTION #	OPTION DESCRIPTION
257NG-70	Power Kit: 70' "2" Gauge Cable – Dual Pole with Combo Box (Dual/Single Pole Receptacles)
269-2B	Battery Hold-Down Kit - 2 Batteries for 42, 48, 60, 72, 80 Gate Width
269-3B	Battery Hold-Down Kit - 3 Batteries for 60, 72, 80 Gate Width
269-4B	Battery Hold-Down Kit - 4 Batteries for 72, 80 Gate Width

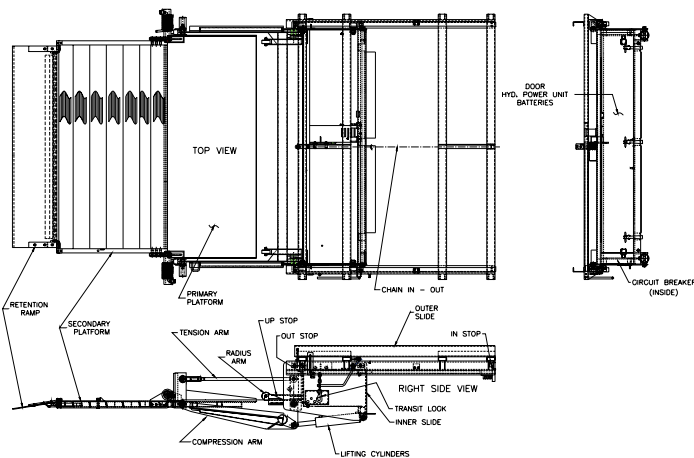



# PATIENT LIFT GATE



# LEYMAN

## LIFT GATES

# GUARDIAN PLG

Patient Lift Gate



### LIFTING CAPACITY 1,000

Meets All DOT Regulations for a Patient Lift Gate

Model Number	Lifting Capacity	Platform Operating Dimensions	Overall Platform Dimensions	Power Kit	Approx. Weight
PLG 1000	1,000 lbs.	73.75" W x 36" D	84" W x 45" D + 21" Flip Ramp	Hydraulic Connection Assembly	1820 lbs.
PLG 1010				Power Unit	

GUARDIAN PLG Standard Features	Benefits
Large True Level Ride Platform	Stabilizes Patient on Gurney or in Wheel Chair with up to 2 assistants
Safety Chain	Safely Secures Lift Gate in Over-the-Road Position
Emergency Hand Pump	Ability to Operate During Power Loss
Inner Roll Stop	Safety Feature During Patient Loading and Unloading
No Alteration to the Side of the Trailer for Gate Installation	Lower Installation Time Needed and Lowers Installation Cost
Mounts Under the Trailer Inside One of the Enclosed Belly Boxes	Stows Out of the Way and Out of Adverse Weather When Not in Use
Pressure Compensated Flow Control	Steady Hydraulic Pressure for Smooth Operation

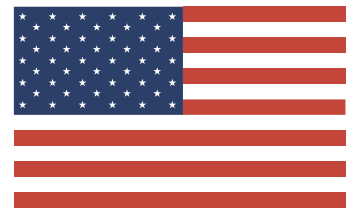

# MADE IN USA



### AVAILABLE OPTIONS

OPTION #	DESCRIPTION
111	Circuit Breaker for Supply Line (PLG1010)
154	Reflecting Tape
273PLG	Hand Rails

05/26



# INTERNAL ELEVATOR LIFT GATE



# LEYMAN

## LIFT GATES

# VALOR LEY-VADOR®

Internal Elevator Lift Gate



**LIFTING CAPACITY 10,000**  
Heaviest Load Capability in the Industry

Floor Heights: 46" Laden/56" Unladen

VALOR LEY-VADOR <i>Standard Features</i>	BENEFITS
True Level Ride Lift Gate	Provides a Safer Working Environment for Driver and Freight
Completely Enclosed When in Transit	Keeps Freight and Delivery Platform from Inclement Weather
Works at Low Dock Heights	Increases Ability to Access Low Dock Locations
Does Not Add Any Length to Vehicle	Increases Ability to Access Tight Delivery Locations
Automatic Platform Locks	Safely Secures Lift Gate in Over-the-Road Position
Push Button Operation	Simple and Easy Operations
Grease Fittings	Reduces Friction
Built-In Lights for Visibility	Increases Visibility for Safety
Single Piece Steel Platform	Quick and Efficient Loading and Unloading
Power Pack Enclosures (2 Versions Available)	Houses Hydraulic Pump and Room for up to Four (4) Batteries
Pressure Compensated Flow Control	Steady Hydraulic Pressure for Smooth Operation

Model Number	Lifting Capacity	Platform Size	Hydraulic Cylinders	Ramp*	Approximate Weight
LEY 6000	6,000 lbs.	83" W x 60" D	2	24" Flip	4,900 lbs.
		83" W x 76" D			5,200 lbs.
LEY 10000	10,000 lbs.	83" W x 76" D	4	24" Flip	6,400 lbs.

VALOR LEY-VADOR <i>Available Options</i>	
OPTION #	OPTION DESCRIPTION
102	102" Wide Vehicle Kit
103	Hand Held Remote, Mounted in Truck/Trailer
214	Maintenance Minder2

VALOR LEY-VADOR <i>Available Options</i>	
OPTION #	OPTION DESCRIPTION
257NG-45	Power Kit: 45' "2" Gauge Cable – Dual Pole with Combo Box (Dual/Single Pole Receptacles)

\* Additional ramp options available