

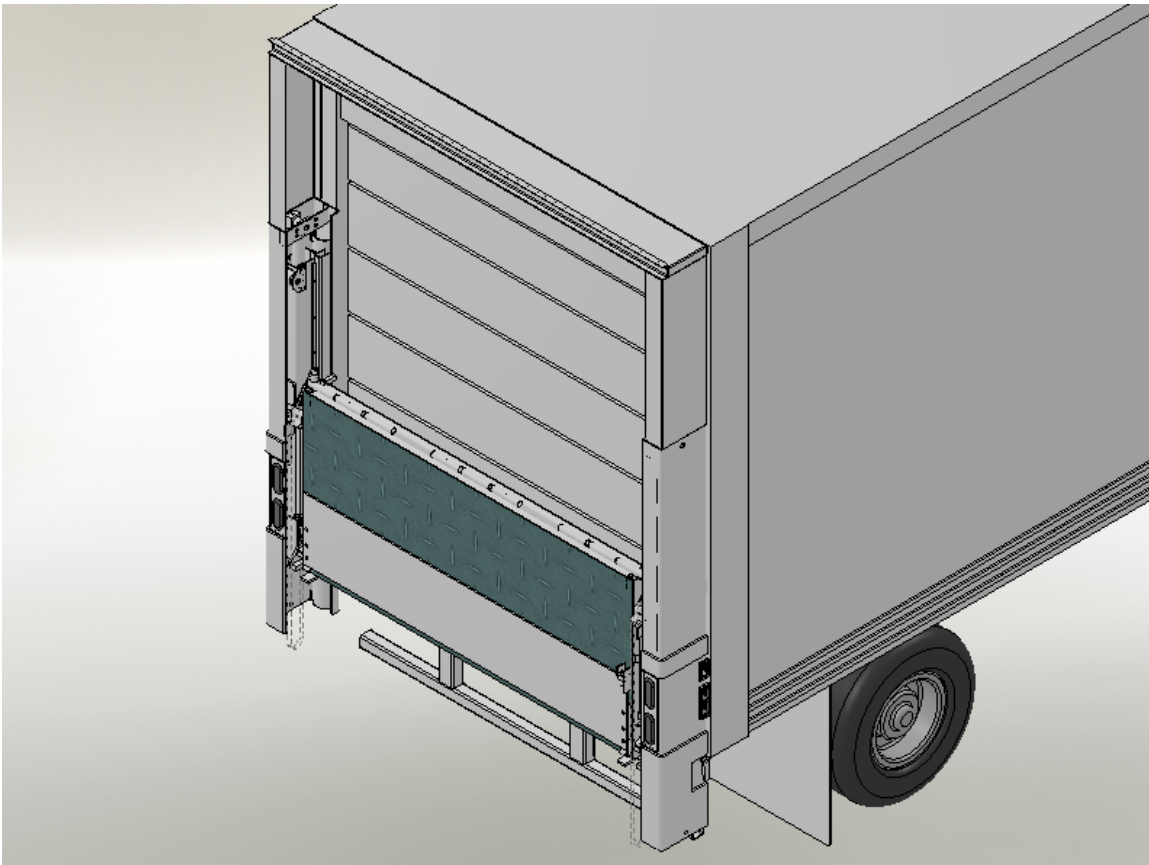

Owner's Manual

FXD Power Down on Demand Fold-A-Vador® Rail Gate



10335 Wayne Avenue • Cincinnati, OH 45215
Ph: 513.891.6210 • Toll-Free: 866.539.6261
Fax: 513.891.4901
www.leymanlift.com • sales@leymanlift.com

LML00423-06/5/24

TABLE OF CONTENTS

Introduction	2
Words of Caution	3
General Terminology	4
Operating the Lift Gate	5
Operating the Dual Power Unit	6
Rec. Hydraulic Oil / Lift Gate Specs / Preventative Maintenance Schedule	7 – 8
Lubricating the Rollers	9
Trouble Shooting Chart / General Trouble Shooting Tips	10 – 13
Electrical Diagrams / Dual Power Unit Connections	14 – 18
Battery Hook Up / Grounding Recommendation	19 – 20
Maintenance Minder 2® Controller	21 – 23
Bleeding the Cylinders	24 – 25
Inner Mast Wear Pad Adjustment / Wear Pad & Fold Stop Parts	26 – 28
Hydraulic Parts Replacement	29 – 31
Replacement Roller	32
Platform Pins and Bushings	33
Switch Wiring Replacement	34 – 35
Power Unit Parts	36 – 43
Divider Valve / Flow Controls	44 - 45
Safety Warning Signs / Decals / Tags	46 – 49
Notes	50

INTRODUCTION

This manual contains the operating procedures on the equipment your company is using that was manufactured by Leyman Manufacturing Corporation.

Past experience has indicated that it is most unwise to operate these units without proper instruction, which should be instituted by the purchaser.

While these products have certain safety features engineered into their design, they are all operated by human beings. Therein lies the problem of safety and one should always have caution in mind when operating this or any other machine that has parts that weigh several hundred pounds.

Again, let us remind you that there are moving parts on this product that weigh several hundred pounds. These parts, when not under proper control, can cause physical damage to the operator. Because of the weights that are involved, carelessness and neglect of training can make these units dangerous.

Do not overload this product. Maintain it properly. Stand clear of moving parts. Operate as instructed.

This lift gate has a long life expectancy and will take some abuse. Use good judgment when operating this equipment.

PLEASE FILL IN FOR YOUR RECORDS

CUSTOMER:	_____
MODEL:	_____
CAPACITY:	_____
TYPE:	_____
POWER:	12 VOLT _____
PLATFORM:	_____
SERIAL:	_____
OPTIONS	_____

MAXIMUM HEIGHT:	56"
HYDRAULIC PRESSURE:	AT BY-PASS 2,500 PSI AT THE PUMP
AMP DRAW:	AT BY-PASS 235, UNLOADED 130
POWER DOWN ON DEMAND	

**WHEN PLACING A PARTS ORDER, PLEASE PROVIDE
THE SERIAL# AND MODEL# OF THE GATE.**

WORDS OF CAUTION

1. BEFORE ANY MAINTENANCE IS PERFORMED ON THIS UNIT, READ AND UNDERSTAND THIS MANUAL COMPLETELY.
2. DO NOT STAND ON OR BEHIND THE PLATFORM WHEN OPERATING GATE IN THE FOLDED POSITION.
3. DO NOT STAND IN FRONT OF THE PLATFORM WHEN LOWERING FROM THE VERTICAL POSITION OR OPERATING IN ANY MANNER.
4. MAKE SURE THE GROUND IS CLEAR UNDER THE PLATFORM WHEN LOWERING.
5. CHECK THE AREA AROUND THE UNIT FOR ANY PERSONS BEFORE OPERATING THE LIFT GATE.
6. NEVER EXCEED THE RATED LOAD CAPACITY OF THIS GATE. DO NOT OVERLOAD - MAXIMUM RATED CAPACITY IS BASED ON AN EVENLY DISTRIBUTED LOAD OVER THE PLATFORM FLAT SURFACE.
7. ALWAYS LOAD AS CLOSE TO THE CENTER OF THE PLATFORM AND AS CLOSE TO THE CENTER OF THE TRUCK SILL AS POSSIBLE.
8. DO NOT ALLOW PERSONS TO OPERATE THE UNIT UNLESS THEY HAVE BEEN PROPERLY TRAINED TO DO SO.
9. USE ONLY FACTORY AUTHORIZED PARTS FOR REPLACEMENT.

THIS MANUAL REFLECTS MOST CHANGES AND UPDATES OF MATERIALS THAT ARE COMMON TO THIS TYPE OF LIFT GATE. SOME MAY DIFFER DUE TO INDIVIDUAL CUSTOMER REQUIREMENTS. THIS MANUAL HAS BEEN ESTABLISHED TO REFLECT THE COMMON ITEMS.

WARNING: THIS GATE HAS POLYMER GREASELESS BEARINGS IN THE PLATFORM PIVOTS, AND CYLINDER. WHEN WELDING BE SURE TO GROUND DIRECTLY TO THE COMPONENT BEING WELDED.

GENERAL TERMINOLOGY

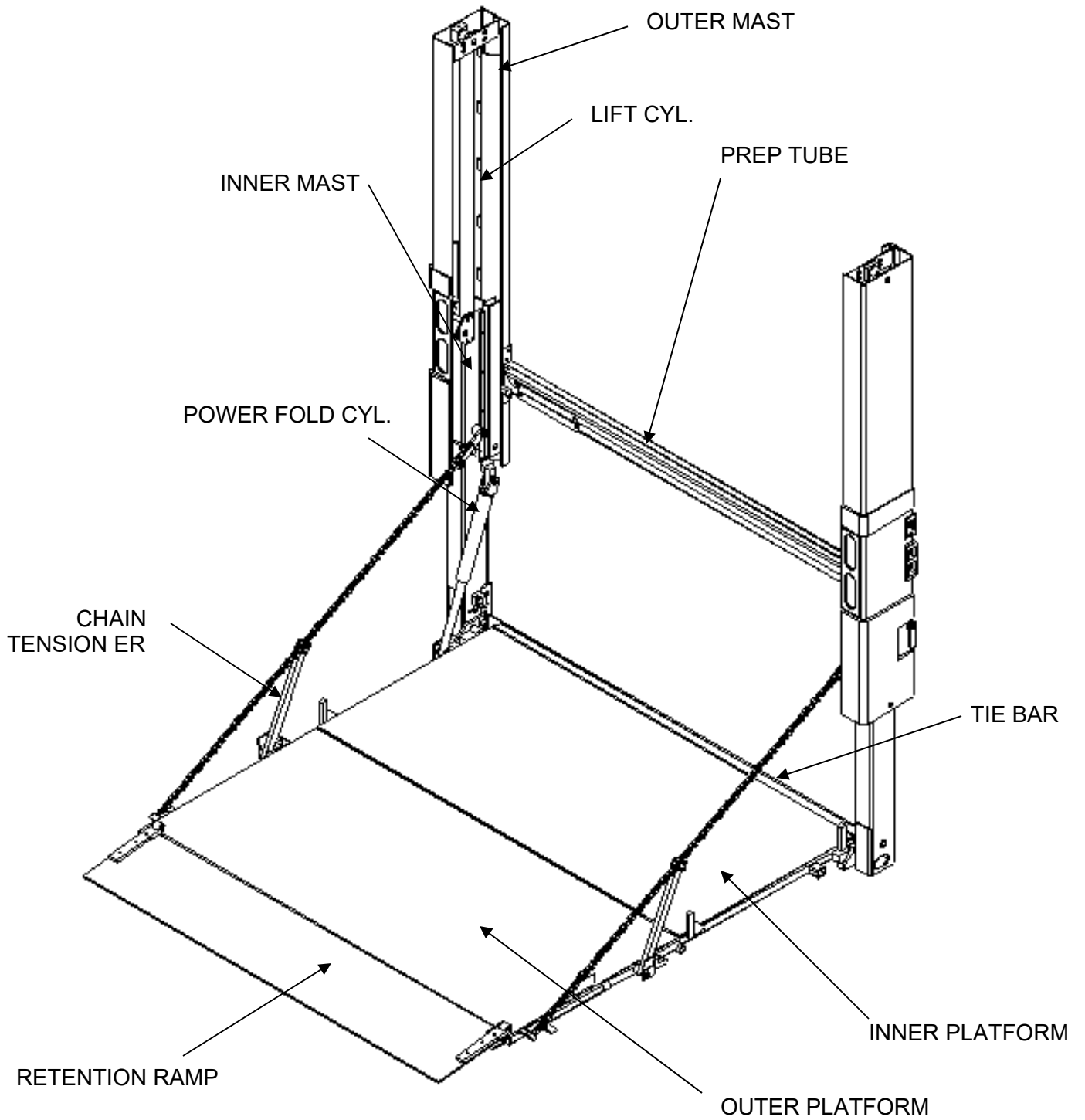

OPERATING THE LIFT GATE

Before operating the lift, read and understand this decal, Urgent Warning decal and Owner's manual.

Do not stand behind lift gate while unfolding or using platform.

To unfold the platform from over-the-road position

1. Toggle the DOWN switch to lower platform.
2. Lower the platform until arrow indicates FOLD / UNFOLD region. Toggle both UNFOLD switches. Gate will unfold.

To dock load

1. Toggle the DOWN switch to lower platform.
2. Continue lowering until platform rests on dock level stops.

WARNING! Never use the platform as a “bridge” to a dock or other vehicle. Platform can fold unexpectedly and cause injury.

To lower platform, use the down switch only.

To raise platform, use the up switch only.

Safe loading of platform

1. Cart stop or retention ramp must be in place whenever lifting or lowering a load. Also, see the Urgent Warning decal.

To fold platform

1. Raise the platform until arrow indicates FOLD / UNFOLD region. Then toggle both FOLD switches until platform completely folds. Raise platform until gate hits Up Stops and arrow indicates locked position. Do not move vehicle unless gate is in locked position.

OPERATING THE DUAL POWER UNIT

Use the power unit Selector Switch mounted inside the power unit enclosure to choose which power unit runs using the gate-mounted switches. The Primary Power Unit is on the left. Secondary Power Unit is on the right.

The emergency Walk-Around Pushbutton control will also operate the Primary and the Secondary Power Unit depending on the position of the Selector Switch.

The Maintenance Minder 2[®] Controller functions with both power units. If you wish to put equal operating time on each power unit, use the Maintenance Minder 2 service intervals (3000 lifts) as the guide for changing the power unit Selector Switches.

The dual power unit also has a selector switch to control the Power Down on Demand function. In the Power Down setting, the motor will run in the down direction. In the Gravity Down setting, the motor will not run in the down direction.

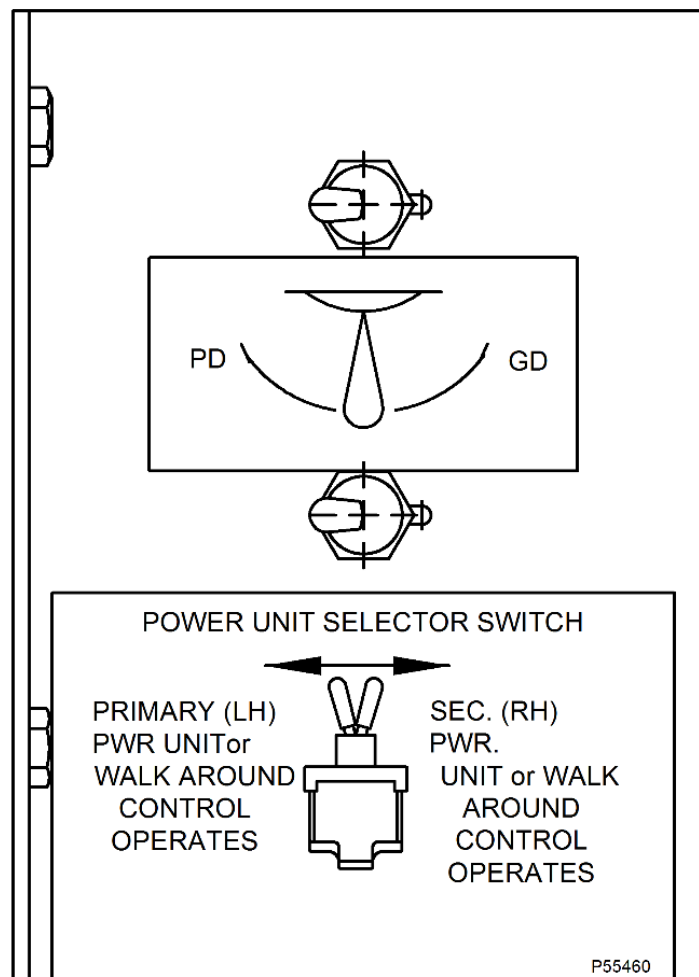

RECOMMENDED HYDRAULIC OILS*

HYDRAULIC OILS	MANUFACTURER	TYPE	TEMP. RANGE
Level 1 Normal Conditions	Mobil	DTE 10 EXCEL 15	-15° F to + 150° F
	Shell	TELLUS S2 VX 15	-15° F to + 150° F
	Chevron	RANDO HDZ 15	-15° F to + 150° F
Level 2 Cold Conditions	Mobil	AERO-HFA	-50° F to + 80° F
	Shell	AERO FLUID #4	-50° F to + 80° F
	Chevron	5606A	-50° F to + 80° F
HYDRAULIC TANK CAPACITY			
2 ½ gallons			
LUBRICATION			
Grease	Level 1 Normal Conditions NLGI #2 Lithium base grease Level 2 Cold Conditions NLGI #1 Lithium base grease DO NOT USE CHASSIS or 5 th WHEEL GREASE		
Rollers at Inner Masts	CAUTION! Do not over-grease to avoid seal damage		
Hinge Barrels (center of platform)	W.W. Grainger – Part #6Y834 – Needle Nose Adapter		
Retention Ramp hold-up tab shaft	W.W. Grainger – Part #6Y834 – Needle Nose Adapter		
Dry Lubricant, if needed	ZEP45 (do not use corrosive lubricants like WD40, etc.)		

*ISO 15 petroleum-based fluid required; see chart for manufacturer cross reference. If necessary, use higher viscosity oil when temperatures are near 100° F.

* **DO NOT USE brake fluid or ATF.**

LIFT GATE SPECIFICATION

BATTERIES
Two (2) 12 V D.C. Group 31 Heavy Duty Lead Acid Dual Purpose or AGM
ELECTRICAL COMPONENTS CONNECTIONS
Use Fluid Film Rust & Corrosion Protection by Eureka, except on Start Solenoid On Start Solenoid, use Color Guard by Loctite, or Liquid Electrical Tape
AMPERAGE DRAW OF MOTOR
When raising platform (empty) approximately 130 AMPS @ 13.5 volts. At bypass approximately 240 AMPS @ 13.5 volts
LIFTING PRESSURE SETTING
With platform at floor level and pump in bypass 2500 PSI Power down circuit in bypass 800 PSI
MINIMUM VEHICLE FLOOR HEIGHT LADEN
With 42" Inner Platform – vehicle floor height 46"
MAXIMUM VEHICLE FLOOR HEIGHT UNLADEN
With 42" Inner Platform – vehicle floor height 56"
APPROXIMATE TIMES EMPTY AT 80° F WITH 2 GROUP 31 BATTERIES
Time up: 24 – 26 seconds Time down (gravity down): 24 – 26 seconds Time down (power down): 14 – 17 seconds

PREVENTATIVE MAINTENANCE SCHEDULE

MAINTENANCE by CYCLES

FXD MODELS

DATE:

CUSTOMER		GATE MODEL #	
LOCATION		GATE SERIAL #	
VEHICLE #		SERVICED BY	

√ = OK X = REPAIR A = ADJUSTED N = NOT APLICABLE

#

3000	MOTOR / PUMP COMPONENTS	3000	MOTOR / PUMP COMPONENTS
	Check batteries for corroded, loose or broken connections		Check charge line/power line for corroded, loose or broken connections
	Check batteries for proper voltage level and charging		Check amp draw of motor with fully charged batteries and tight clean connections
	Check all wiring in pump box for corroded, loose or broken connections		Check all ground wires for corroded, loose or broken connections
	Check solenoid valves for proper operation		Check pressure setting of relief valve (two valves in power down pumps)
			After all wiring connections in pump and battery box have been cleaned, protect from corrosion using materials listed in Lift Gate Specification section.
	Check reservoir for proper oil level - Gate open and up at floor level, 4" from top of tank.		Operate both power units to verify proper operation.
	Inspect circuit breakers and fuses for proper operation		Check all fittings / hoses in power unit for tightness and leaks

#

3000	STRUCTURAL COMPONENTS	3000	STRUCTURAL COMPONENTS
	Check switches for proper operation, check connections for tightness and corrosion		Remove hydraulic guard for fold cylinder line and check for loose / missing clamps, frayed lines, and proper alignment
	Check all fittings/hoses on cylinders for tightness and leaks		Check lift gate for proper operation up and down
	Check fold cylinder for leaks / worn rod seal		Check lift gate for proper operation folding and unfolding
	Check for broken/missing roll pins at fold cylinder, and primary/secondary platform pin		Check for impact damage on inner/outer masts
	Check snap rings on lift and fold cylinder pins		Check for loose / missing bolts at platform pins, platform chains, rollers, and bottom cylinder pins
	Check for broken torsion spring at platform		Check and re-weld any cracked / broken welds
	Check aluminum platform for loose bolts on side brackets and threaded plugs at hinge pins		Replace all safety and warning labels as needed

#

3000	LUBRICATION		PERIODIC CHECK LIST
	Grease roller bearings at grease holes on roller shaft with recommended grease. DO NOT OVER-GREASE	12000	Check all pivot point bushings for wear or damage
	Grease primary / secondary platform hinge pin at grease holes, plus Retention Ramp Hold-up Tab shaft support.	16000	Flush hydraulic system and change hydraulic oil
			Clean and repaint as necessary

#

MAINTENANCE MINDER ² READINGS MENU 2			
Screen 1 # Lifts	Screen 3 Service Faults	Screen 4 Low Voltage Faults	Screen 6 High Temperature Faults

Check owner's manual for proper hydraulic oil, motor amp draw, and pressure setting of power unit

Revised August, 2015

LUBRICATING THE ROLLERS

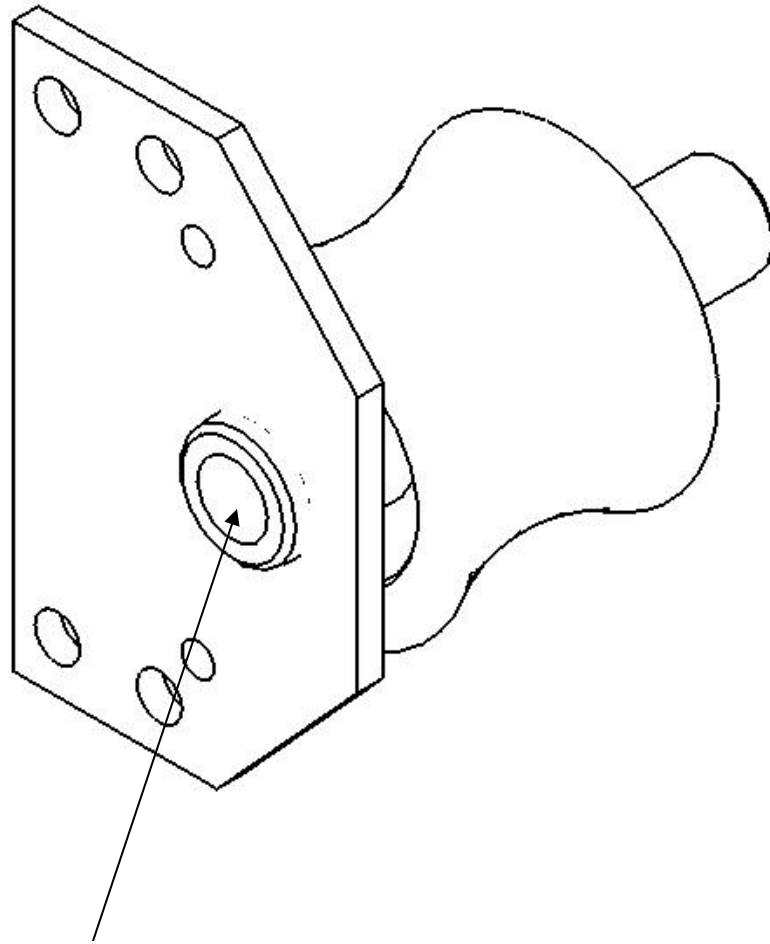

Lubricate roller through grease fitting mounted on roller shaft.
(Picture shows isolated roller assembly but it can be greased when mounted on Inner Mast). **CAUTION! DO NOT OVER-GREASE ROLLERS OR DAMAGE TO BEARING SEALS MAY OCCUR.**

TROUBLE SHOOTING CHART

The following troubleshooting chart covers the standard dual power unit used with the FXD®.

PROBLEM	PROBABLE CAUSE	REMEDY
Platform will not go up or reach the floor of the vehicle.	<ol style="list-style-type: none"> 1. Battery is low. 2. Slave line is disconnected, or connections are loose (battery and motor). 3. Insufficient oil in power unit tank. 4. Poor switch connections. 	<ol style="list-style-type: none"> 1. Recharge the battery. 2. Connect the slave line properly. 3. Fill the power unit tank. 4. Clean and check switch connections in power unit box.
Platform will not lower.	<ol style="list-style-type: none"> 1. Battery is low. 2. Poor switch connections. 3. Check lowering valve "D" 	<ol style="list-style-type: none"> 1. Recharge the battery. 2. Clean and check switch connections in power unit box. 3. Clean/replace as necessary. Try manual overrides.
Platform does not go up smoothly.	<ol style="list-style-type: none"> 1. Insufficient oil in power unit tank. 2. Air lock in hydraulic system. 3. Dirt or foreign material in guides. 4. Mechanical wear. 	<ol style="list-style-type: none"> 1. Fill tank. 2. Run platform to stop. Open up vent plugs in each cylinder while power unit is running. Close vent plugs and refill the tank. 3. Clean guides with steam and check for excessive wear, obstructions, and burrs. 4. Replace worn parts.
Platform creeps down.	<ol style="list-style-type: none"> 1. Hydraulic leak. 2. Cylinder piston seal failing. 3. Check lowering valve "D" 	<ol style="list-style-type: none"> 1. Check all hoses and fittings. 2. Replace cylinder or seals. 3. Clean / replace as necessary. Manual over-ride must be IN and turned CLOCKWISE.
Platform goes down slowly.	<ol style="list-style-type: none"> 1. Incorrect hydraulic oil in system for cold weather. 2. Excessive wear of mechanical components. 3. Restriction in hydraulic system. 	<ol style="list-style-type: none"> 1. Use recommended viscosity for hydraulic oil. 2. Ensure free movement of all mechanical parts. 3. Check all hydraulic system components.
Platform goes up crooked.	<ol style="list-style-type: none"> 1. Equalizer valve is out of adjustment. 2. Air trapped in one of the cylinders. 3. Tie bar is bent. 	<ol style="list-style-type: none"> 1. Adjust equalizer valve. 2. Bleed air out of the cylinders. 3. Replace the tie bar.

TROUBLE SHOOTING CHART (Cont.)

PROBLEM	PROBABLE CAUSE	REMEDY
Platform comes down crooked.	<ol style="list-style-type: none"> 1. Dirt in flow control, not adjustable. 2. Restriction in hydraulic line for lift cylinder. 3. Mechanical bind on one side of gate. 4. Tie bar is bent. 	<ol style="list-style-type: none"> 1. Clean / replace flow control valves (matched pair) as necessary. 2. Clean hydraulic line and bleed cylinders. 3. Clean and inspect inner mast and rollers. Check wear of parts and replace if necessary. 4. Replace tie bar.
Gate will not lift the rated load.	<ol style="list-style-type: none"> 1. Hydraulic pump is worn. 2. Battery is too low. 3. Pressure relief valve not set properly at 2500 psi. 	<ol style="list-style-type: none"> 1. Change the pump. 2. Recharge the battery to full charge. 3. Adjust pressure relief valve.
Pump will not operate.	<ol style="list-style-type: none"> 1. Battery too low. 2. Electrical hookup to motor not making contact. 3. Control switches are not properly connected at power unit. 4. Maintenance Minder 2[®] Controller has shut down the system due to low voltage. Must maintain 8 volts minimum under load. 	<ol style="list-style-type: none"> 1. Recharge the battery and check to be sure that the slave line has a good connection. 2. Clean connections and re-tighten. 3. Check switches for proper connections. Check for proper operation. 4. Use the "Last Lift Menu" to read maximum and minimum voltages. Recharge battery.

GENERAL TROUBLE SHOOTING TIPS

LIFTGATE

1. This gate can run up or down crooked 1" to 1-1/2" without hurting the gate.
2. Equalizer Valve – for adjusting the up stroke only, when the gate is loaded.
3. Flow Control Valves – for controlling the down stroke only. A partially blocked flow control valve will reduce oil flow from one side, causing the platform to become progressively unlevel as the gate is lowered. Clean or replace in sets.
4. Bent Tie Bar – how to tell if it is bent: raise the platform to the full up position (level with the truck floor). Push the down switch. If the tie bar is bent, one side will always drop quicker than the other side immediately, and that side will always lag when the gate is raised. If bent, the tie bar will need to be replaced. **BEFORE ADJUSTING OR ATTEMPTING TO FIX ANY OF THE FOUR ITEMS LISTED ABOVE, CHECK THE FOLLOWING FIRST:**
 - a. Check for bent inner mast.
 - b. Check to see if the back edge of the platform is hitting or binding against the floor level tube.
5. Premature motor failure is almost always caused by low batteries – batteries without the capacity to maintain the correct voltage during the operation of the gate.
6. Inadequate grounding is also a major reason for motor failure.

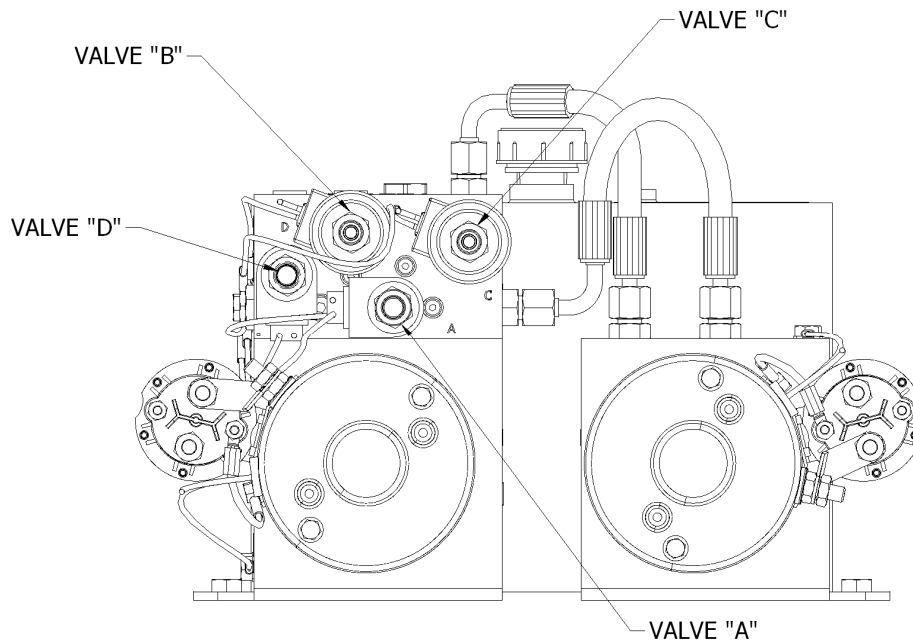

GENERAL TROUBLE SHOOTING TIPS (Cont.)

Operation desired	Symptoms	Directions to identify problem.	Did the gate do the desired operation?	Diagnosis
Up	The gate does not go up but the motor runs	Manually override two-way locking valve "B" (See figure below)	Yes	"B" Valve or wiring is defective. Return valve to non overridden position once you have the gate in the stored position.
			No	Pump is bad.
Power / Gravity Down	The gate does not go down, but motor runs	Manually override locking valve "D" (See figure below)	Yes	"D" Valve or wiring is defective. Return valve to non overridden position once gate is in desired position.
			No	"A" Valve or wiring is defective.
Fold	The gate does not fold but the motor runs	Manually override two-way locking valve "C" (See figure below)	Yes	"C" Valve or wiring is defective. Take the gate to the stored position using the push and hold override button.
			No	Pump is bad.
Unfold	The gate does not unfold	Manually override Two-way locking valve "C" (Check that platform has cleared the unfold locks on both sides).	Yes	"C" Valve or wiring is defective. Take the gate to the stored position using the push and hold override button.
			No	"A" Valve or wiring is defective.

ELECTRICAL DIAGRAM

BEFORE NOVEMBER 2016

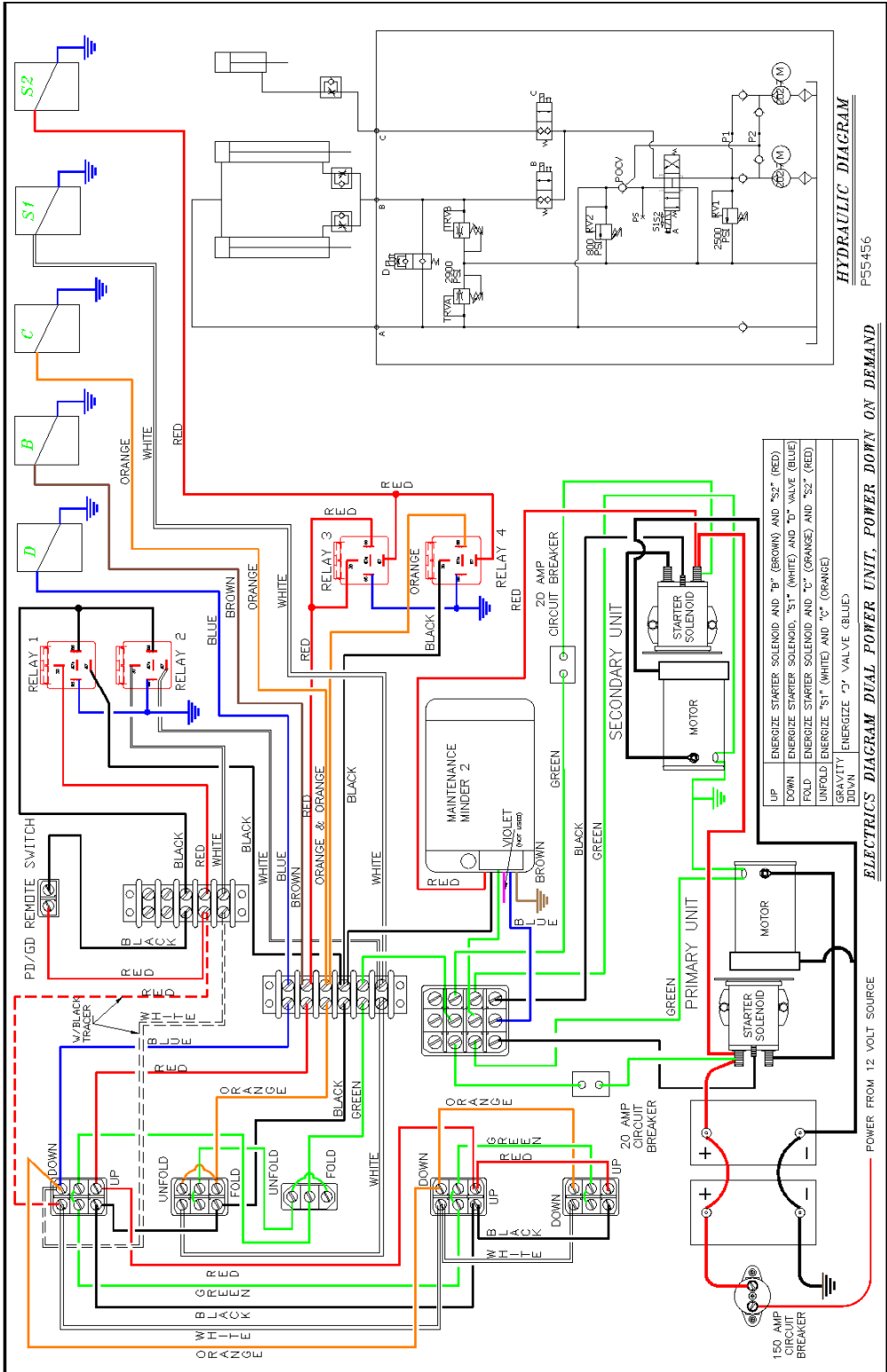

FROM NOVEMBER 2016 -TO APRIL 2018

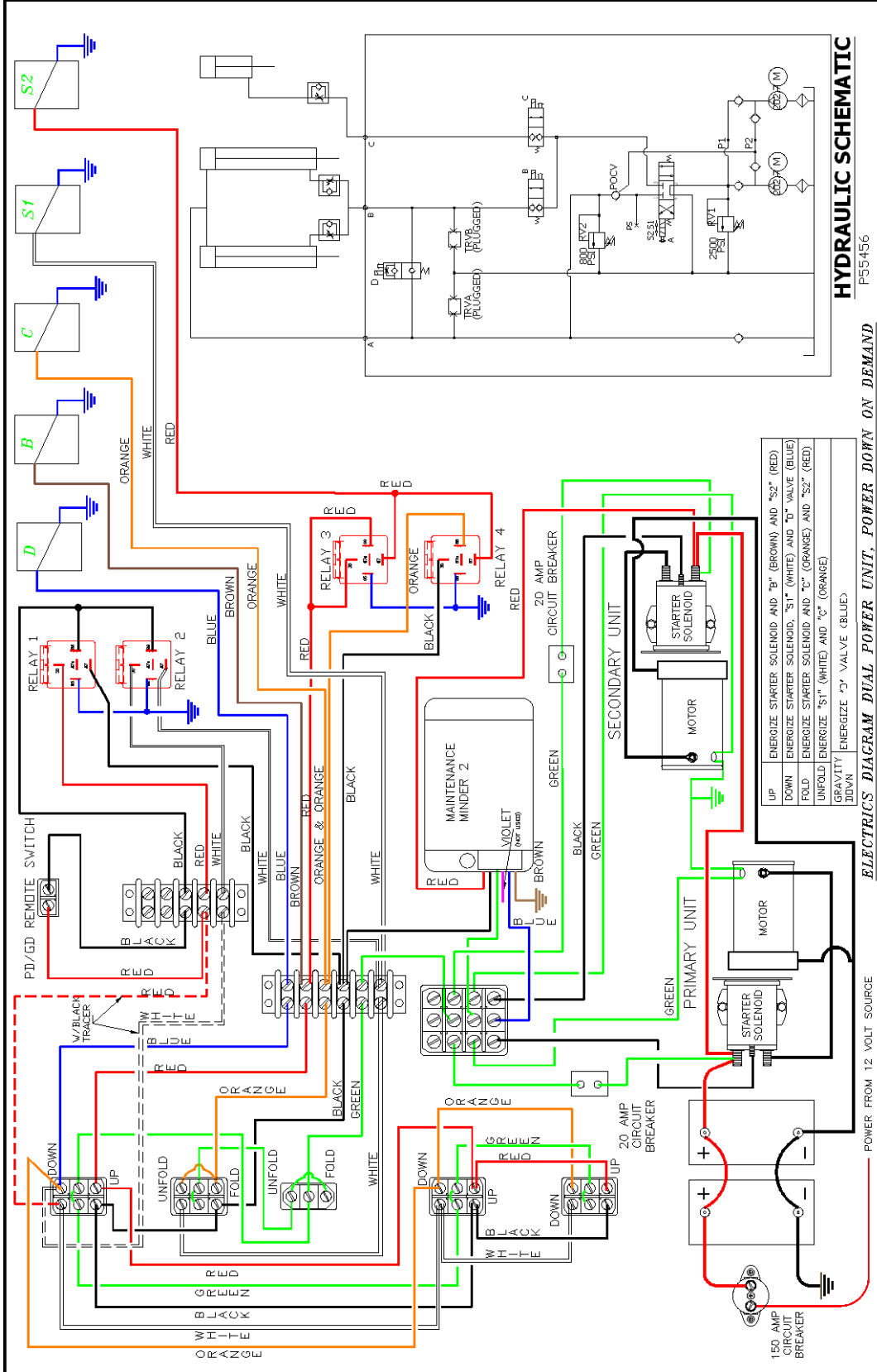

DUAL POWER UNIT CONNECTIONS

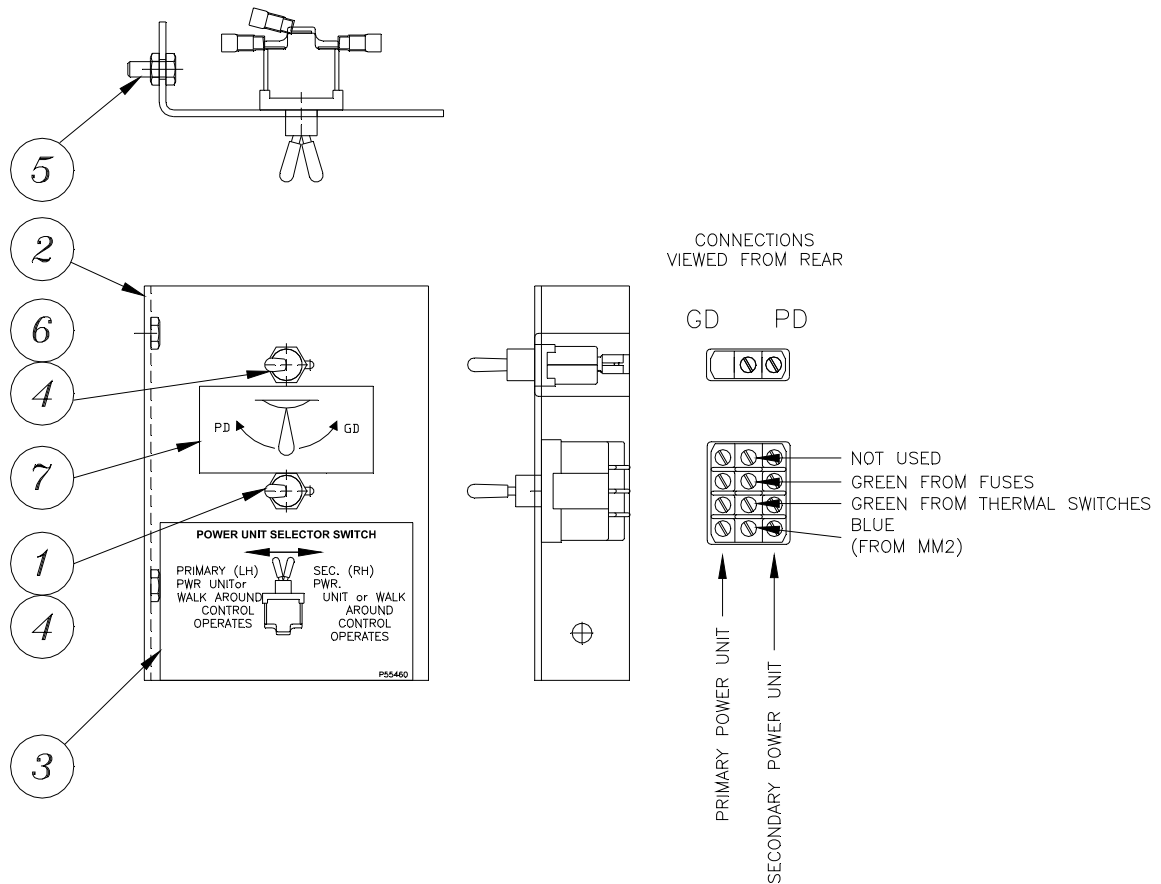

Index No.	Qty	Part Number	Part Name	Remarks
1	1	P46599	Switch	2 position, 4 pole
2	1	AA-551-555	Mtg. Plate Assy	
3	1	P55460	Selector Switch Decal	
4	2	P46291	Rubber Boot	
5	2	P10517	Bolt	1/4-20 x 5/8
6	1	P46865	Switch PD-GD	2 position
7	1	P55455	PD/GD Decal	

DUAL POWER UNIT CONNECTIONS (Cont.)

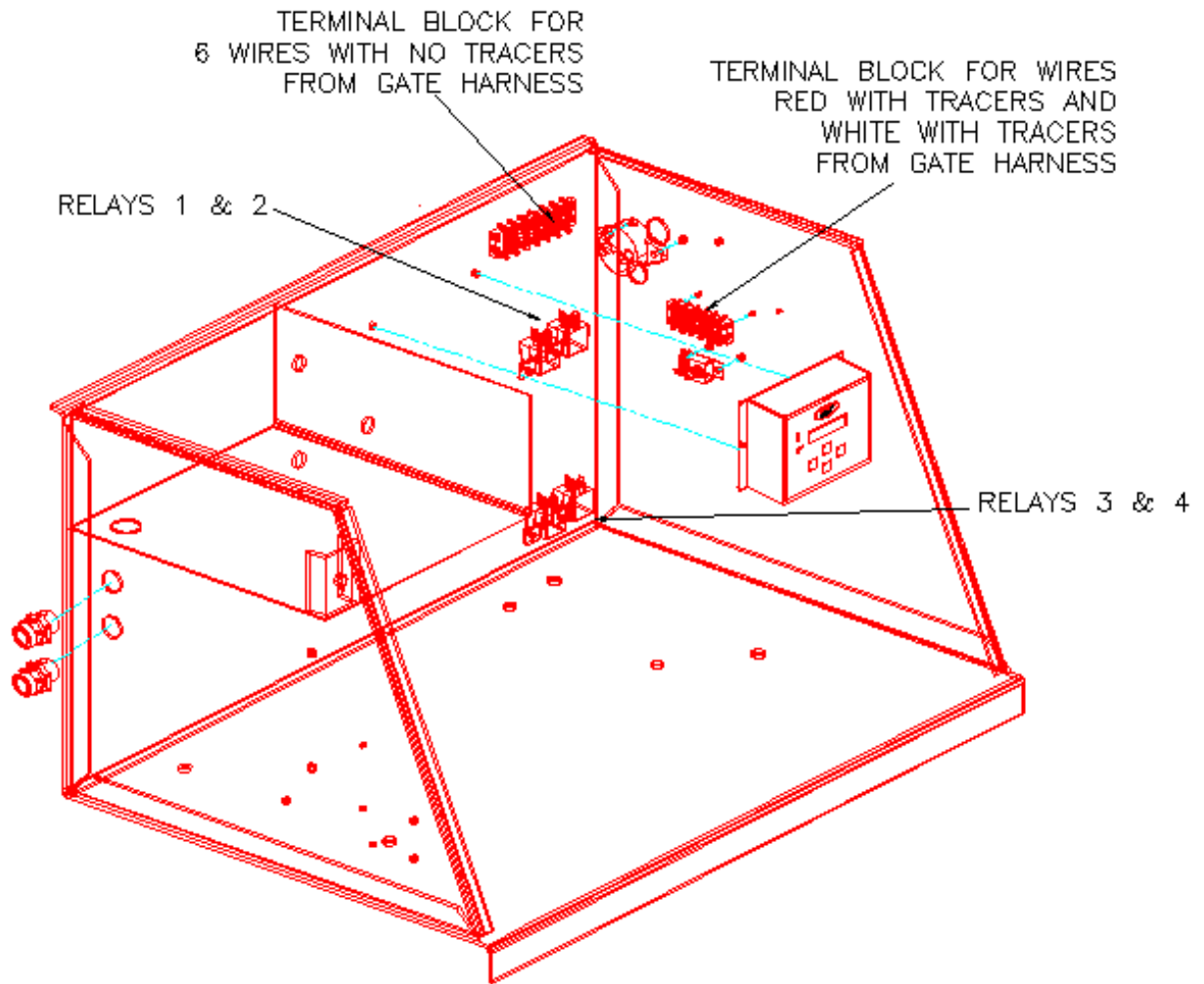

BATTERY HOOK UP

We recommend batteries with the following specifications:
 12 Volt Heavy Duty Lead Acid Dual Purpose or AGM
 B.C.I. Group – Size 31
 Terminal Type – Threaded Stud
 Cold Cranking Amps – 580 Min.

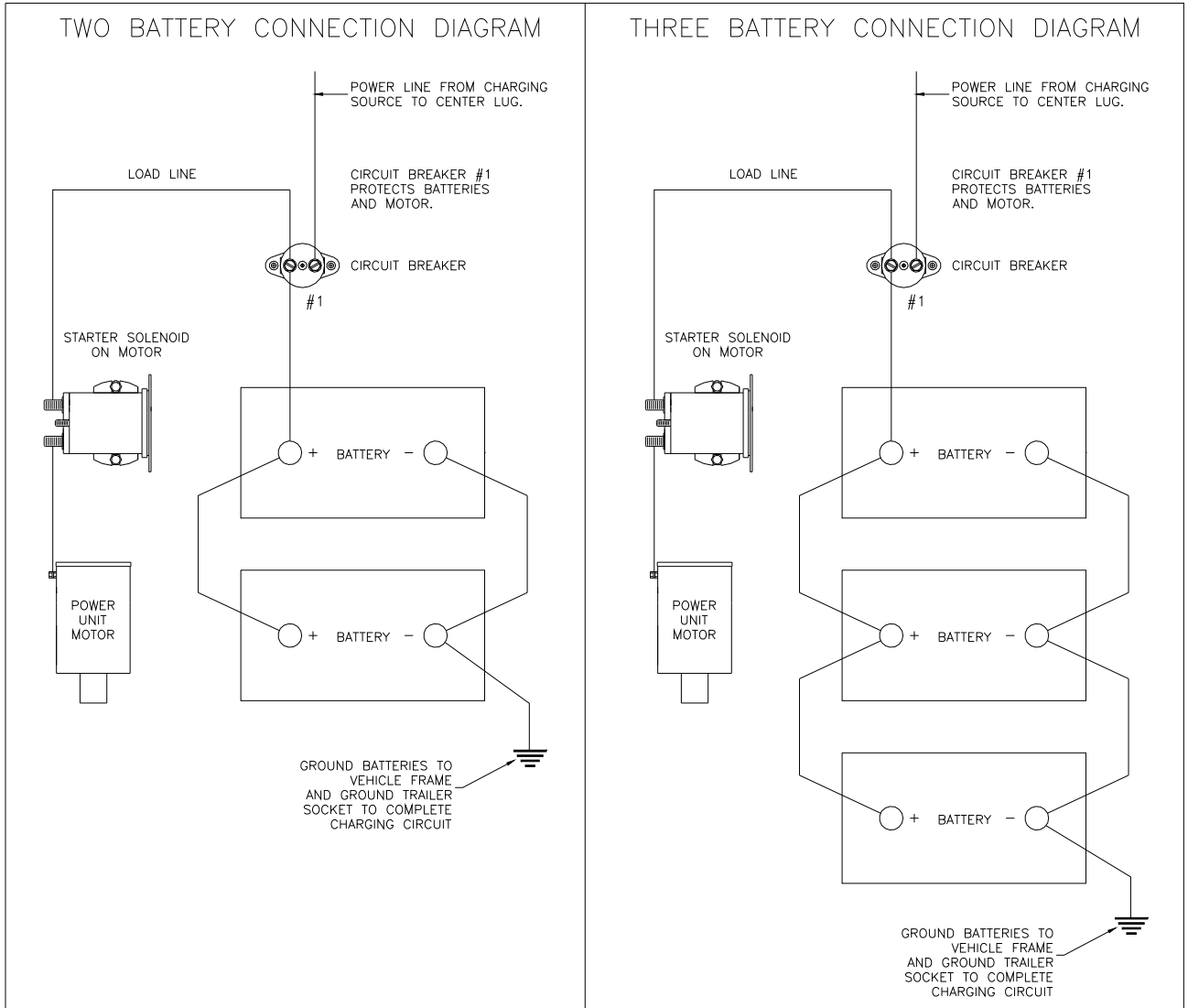

Note: placing the charge line(s), load line(s) and ground cable on the same battery will result in unequal charging and discharging of the batteries. The (+) and (-) connections must be made across the entire battery bank (one connection on the first battery and the other connection on the last battery).

Place rubber pads under each battery to prevent movement, and securely tighten Battery Clamp.

FAILURE TO USE CORRECT BATTERIES WILL VOID WARRANTY

GROUNDING RECOMMENDATION FOR TRACTOR/TRAILER

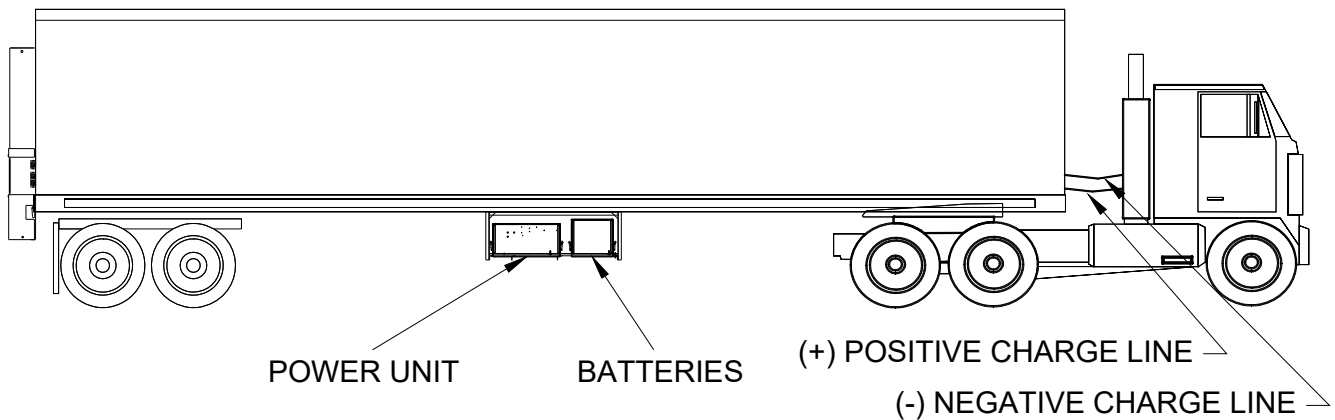

The MAINTENANCE MINDER 2[®] controller requires that a minimum of 8 volts be maintained under load in order for the FXD[®] power unit to operate. Using a single positive cable and utilizing the fifth wheel plate as the ground may not be adequate. Therefore, our recommendation for grounding tractor/trailers with a FXD[®] gate is as follows:

Two (2) cables: one (1) positive and one (1) negative, both running to the tractor batteries.

NOTE:

The use of a battery charger as the sole power source to operate a FXD[®] is unauthorized and will prevent the FXD[®] from working properly. The lift gate must always be operated in conjunction with at least one (1) 12-volt dual purpose heavy-duty lift gate battery. A minimum of 10.5 volts must be maintained in order for the valves to operate.

MAINTENANCE MINDER 2[®] OVERVIEW

Power unit is equipped with the Maintenance Minder 2[®] Controller. It will:

- Automatically keep track of maintenance intervals and warn the user when maintenance is due, based on the number of lifts.
- Record low voltage occurrences.
- Record of high temperature faults.
- Record of maximum run time faults, when a single operation exceeded the maximum continuous run time limit.
- Give helpful trouble-shooting information on MENU 4, “Last Lift Info”.

FAULTS CODES

A decal in the power unit enclosure lists the following signal codes for these faults:

1 BEEP	Service Fault (reached the number of lifts when maintenance is due)
2 BEEPS	Low Voltage Fault (check battery condition and power line connections)
3 BEEPS	Max. Time Fault (exceeded the maximum continuous run time allowed)
4 BEEPS	High Temperature Fault (unit will not run until motor cools)

All fault signals will be repeated FOUR times, except the Service Fault signal. Controller will prevent power unit from operating during the time period when a fault signal is sounding (about 5 to 10 sec.) except for the Service Fault signal. The controller is also equipped with an anti-doorbelling feature, which prevents rapid ON/OFF operation of the power unit.

RESETTING after MAINTENANCE IS PERFORMED

To RESET the Maintenance Minder 2[®] after maintenance has been performed:

1. Go to MENU 2, hit “ENTER”, and toggle down to the “Reset All Info” screen.
2. Press and hold the hidden RESET button under Maintenance Minder 2[®] logo at top of faceplate.
3. Follow the instructions on the screen regarding a second button, which must be pressed to complete the reset operation.



MAINTENANCE MINDER 2® CONTROLLER MENUS

(Press MENU)

MENU 1 – LIFT GATE INFO

(Press ENTER, then ARROW DOWN for each item)

Model Number, Serial Number, Manufacture Date, Vehicle ID, Hardware Version, Firmware Version, Software Version.



(Press MENU and ARROW DOWN once)

MENU 2 – PERIOD INFO (data for current maintenance period)

(Press ENTER, then ARROW DOWN for each item)

Number of Lifts (gives the number during this maintenance interval and the set number when maintenance is due)

Motor ON (total motor run time in minutes for this maintenance period)

Service Fault (number of times gate was operated PAST the maintenance limit)

Max. Time Faults (times motor exceeded its maximum allowable continuous run time)

High Temperature Faults (times thermal switch in motor tripped, if switch provided)

Low Voltage Faults (times low voltage occurred)

Reset all Info (Reset data after performing maintenance, once maintenance limit is reached – see reset instructions on previous page)



MAINTENANCE MINDER 2[®] CONTROLLER MENUS

(Press MENU and ARROW DOWN twice)
MENU 3 – LIFE TIME INFO (data for the total life time of the gate)

(Press ENTER, then ARROW DOWN for each item)

Same items will appear as under PERIOD INFO, except this is LIFE TIME data.

Reset History (reviews history for each maintenance interval)

Press ENTER, then ARROW DOWN to show history. Most recent period is the highest #. Screen shows Period #, # of Lifts, and Total Run Time in minutes.



(Press MENU and ARROW DOWN three times)

MENU 4 – LAST LIFT INFO (Trouble Shooting Screen – it records data that occurred during the last lift made)

(Press ENTER, then ARROW DOWN for each item)

Supply Voltage (first voltage is the minimum voltage that occurred during the last lift – if below 6 volts gate will stop / second voltage is the supply voltage just before gate operation, must be at least 10 volts).

Motor ON (motor run time in seconds during last lift, gate will stop at 180 seconds).

Window Time (time in milliseconds during the last lift that the voltage dropped in between 6 and 8 volts – must not be any longer than 3 seconds or gate will stop).



NOTE:

Controller has an anti-doorbelling feature. Motor will not operate if UP switch is toggled rapidly. This prevents welding of the start solenoid contacts.

BLEEDING THE LIFT CYLINDERS

The FXD® is shipped with the cylinders pre-filled with hydraulic fluid from the factory. *The cylinders must be bled before making any other adjustments.*

To Bleed the Lifting Cylinder – Bottom Side:

1. Unfold and lower the platform to the full down position. **CYLINDERS SHOULD BE EXTENDED TO THEIR FULL LENGTH (GATE EXTENDED DOWN 56") TO REMOVE AS MUCH AIR FROM THE BOTTOM SIDE OF THE CYLINDER AS POSSIBLE. DEPENDING ON THE FLOOR HEIGHT OF THE VEHICLE, IT MAY BE NECESSARY TO RAISE THE BODY OF THE VEHICLE OR LOWER THE GATE PLATFORM INTO A PIT TO ACHIEVE MAXIMUM CYLINDER EXTENSION.**
2. Loosen the plugs in the back ports (ports closest to the vehicle body), but do not remove completely.
3. Activate the pump just long enough to produce an air-free stream of oil from the ports.
4. Re-tighten the plugs in the ports, raise the platform to the full up position, and check the oil level in the reservoir tank. The oil level should be approximately 4" from top of the tank.

To Bleed the Lifting Cylinders – Top Side

1. Unfold and raise the platform to the full up position to remove as much air from the top side of the cylinder as possible.
2. Loosen the plugs in the front ports (ports furthest from the vehicle body) but do not remove completely.
3. Activate the pump (DOWN) just long enough to produce an air-free stream of oil from the ports.
4. Retighten the plugs in the ports, raise the platform to the full up position if not already there, and check the oil level in the reservoir tank. The oil level should be approximately 2" from top of the tank for DUAL power units.

NOTE: FOR POWER DOWN GATES, OIL LEVEL SHOULD ALWAYS BE CHECKED WITH THE PLATFORM UNFOLDED AND RAISED ALL THE WAY UP.

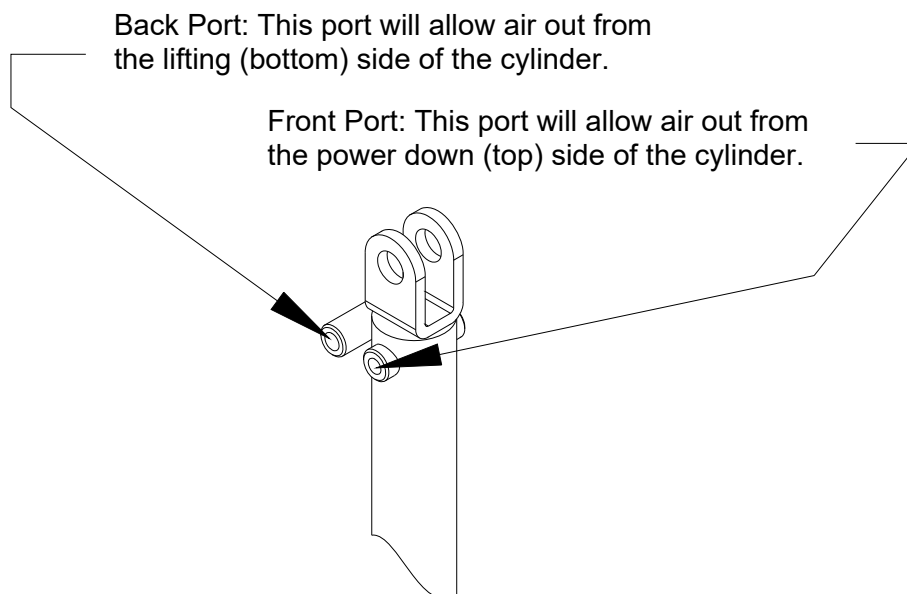

TO BLEED THE POWER FOLD CYLINDER

1. Unfold and lower the platform down to the ground.
2. Loosen the hose at the cylinder but do not remove completely.
3. Activate the pump just long enough to produce an air free stream of oil from the hose.
4. Re-tighten the hose and check the oil level in the reservoir tank. Note: hold line while tightening to ensure it does not twist.
5. Fold and unfold the platform several times. The platform should now fold and unfold smoothly.

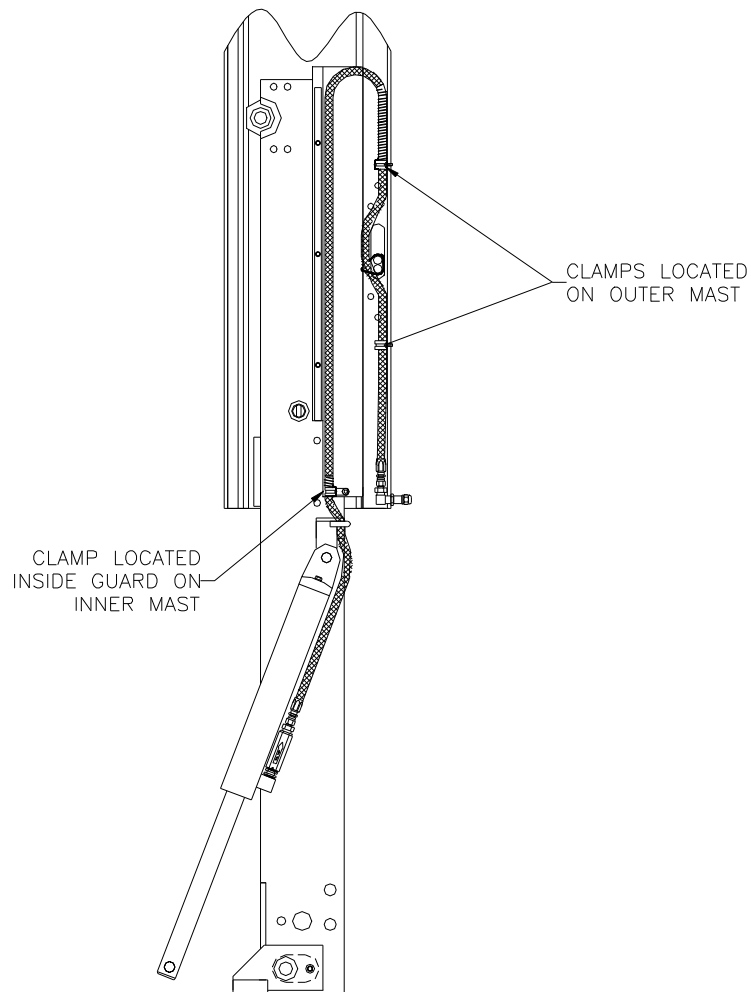

CHECK OIL LEVEL AFTER BLEEDING THE CYLINDER:

Check with platform unfolded and up at bed height.

INNER MAST WEAR PAD ADJUSTMENT

If platform comes down even when **UNFOLDED**, but comes down crooked when **FOLDED**, this could indicate the Inner Mast Wear Pads need adjustment. There is a Wear Pad opposite each roller on the Inner Mast (total of four Wear Pads)

FOLLOW THESE STEPS TO CHECK THE INNER MAST WEAR PAD ADJUSTMENT:

1. **PLATFORM MUST BE UNFOLDED TO MEASURE WEAR PAD CLEARANCE.** Unfold the platform and run lift gate UP and DOWN at least one complete trip to assure rollers are seated in their track. Rollers must be completely seated in order to obtain a correct measurement at each Wear Pad.
2. Measure Wear Pad clearance at each location (total of 4 Wear Pads) with the platform unfolded in three (3) different positions – all the way up, in a middle position, and all the way down on the ground. You will have a total of 12 Wear Pad clearance measurements – three for each Wear Pad. Write the readings down for easy reference.
3. Refer to the diagram on the following page and take clearance measurements at each Wear Pad using a Feeler Gauge. As an example, the top Wear Pad on the curb side might have clearance measurements of 0.080” (gate in top position), 0.092” (middle position), and 0.100” (gate at ground). Slotted Shim AP-999-214 is 0.060” thick, so one more shim can be added, since all three readings for this Wear Pad exceed 0.060”. If any of the three measurements were near 0.060” or less, then no shims could be added.
4. To add shims, loosen the 3/8-16 Hex Head Cap Screws using a 9/16 open end wrench. Insert additional shims, then tighten 3/8-16 screws. The objective is to shim each Wear Pad as close as possible, without the Wear Pad touching the track at any position (top, middle, or ground position).
5. After shim adjustments are complete at all four Wear Pad locations, run platform UP and DOWN unfolded to verify correct operation. Then fold platform and run gate UP and DOWN folded to verify correct operation.

INNER MAST WEAR PAD ADJUSTMENT (cont.)

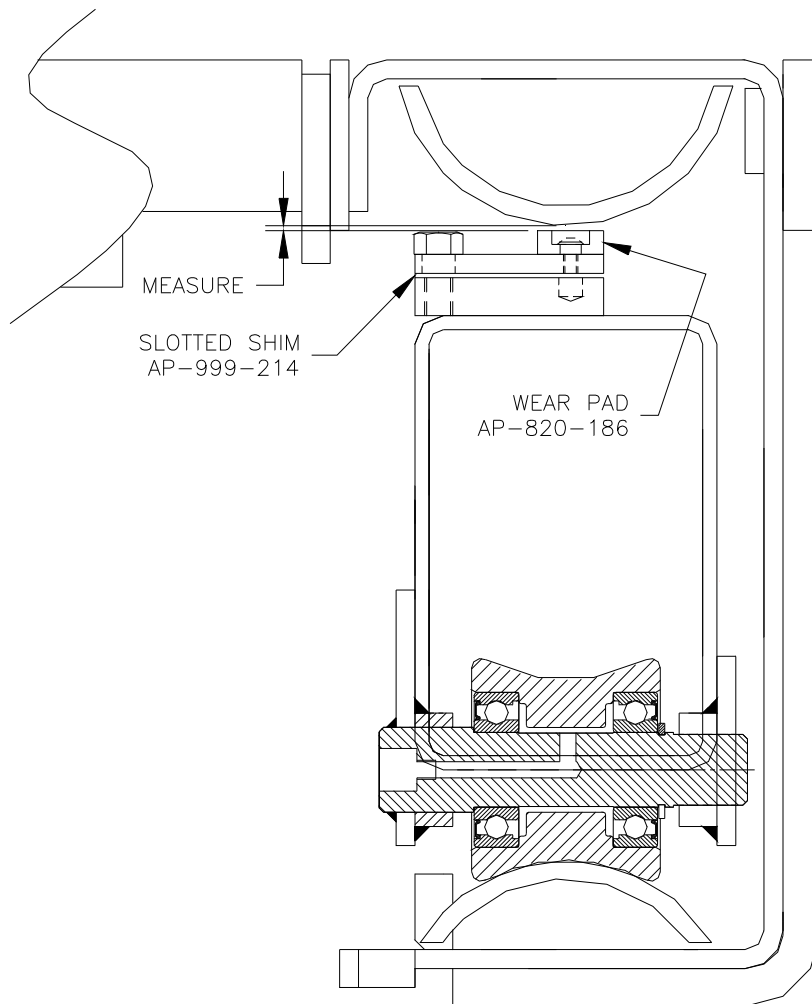

ALL MEASUREMENTS MUST BE
TAKEN WITH PLATFORM UNFOLDED

CURB SIDE MAST VIEWED FROM ABOVE

INNER MAST WEAR PAD PARTS

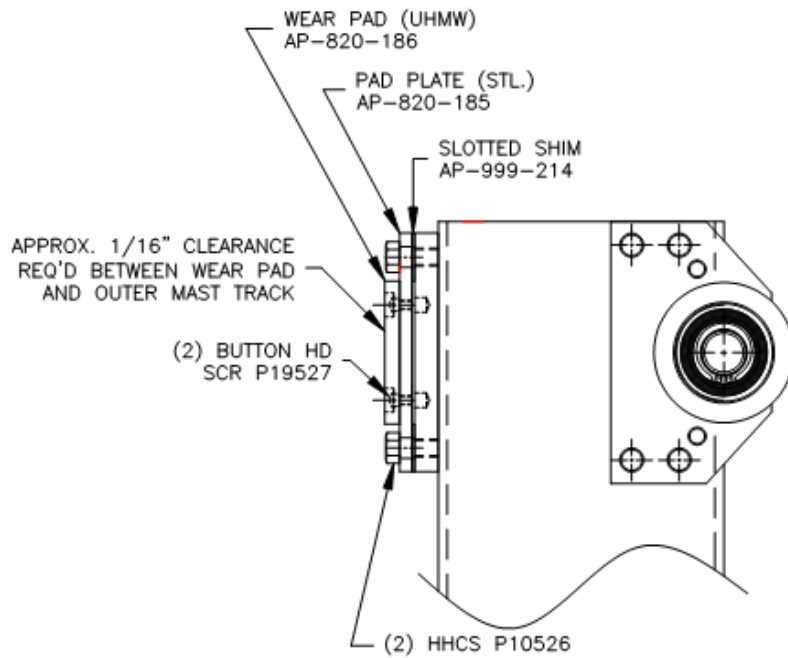

CHECK WEAR PAD CLEARANCE WITH PLATFORM UNFOLDED. RUN PLATFORM UP AND DOWN TO SEAT ROLLERS. CHECK CLEARANCE WITH GATE POSITIONED AT DIFFERENT VERTICAL LOCATIONS.

INNER MAST FOLD STOP PARTS

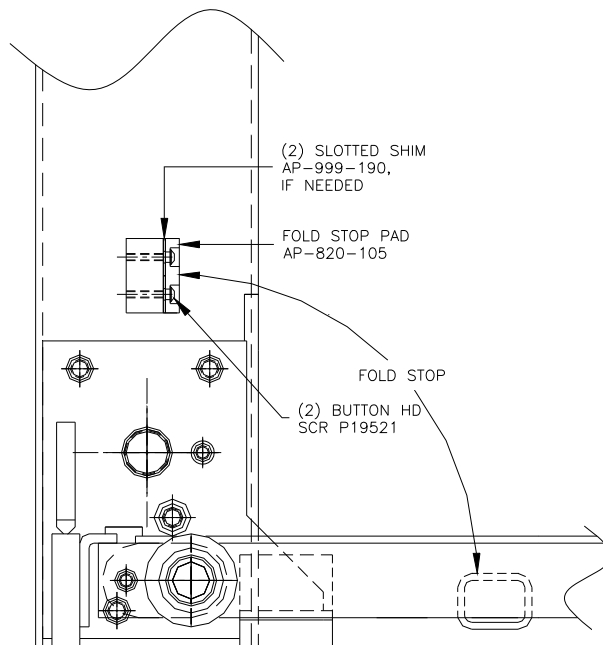

HYDRAULIC PARTS REPLACEMENT

Index No.	Qty Req'd	Part Number	Part Name	Remarks
1	2	P34101	Hyd. Cylinder	SEE NEXT PAGE
2	1	AT-501-354-081	Hydraulic Line Assy.	LH Lifting
3	1	See Chart	Hydraulic Line Assy.	LH "Down" Line
4	1	See Chart	Hydraulic Line Assy.	RH Lifting
5	1	See Chart	Hydraulic Line Assy.	RH "Down" Line
6	2	P34102	Velocity Fuse 4.5 GPM	SEE NEXT PAGE
7	4	P34103	Long Nipple	
8	4	P34015	Elbow	
9	1	P34145	Bulkhead Tee	
10	1	See Chart	Hydraulic Line Assy.	
11	3	P34106	Bulkhead Elbow	
12	4	P34107	ORB Plug	
13	4	P34058	Adapter	
14	1	P34051	Elbow	
Not shown	2	AP-820-203	Ram Mtg. Pin Top	HDW: P47505 Roll Pin
Not shown	2	BA-820-262	Ram Mtg. Pin Lower	HDW: P11021 Bolt
Not shown	2	P43570	Lower Ram Mtg Pin Bushing	1" id x 1/2" long
Not shown	2	P43587	Lower Ram Mtg Pin Bushing	1" id x 3/4" long
Not shown	3	P46497	3/4" Split Loom	24" Lg ea.

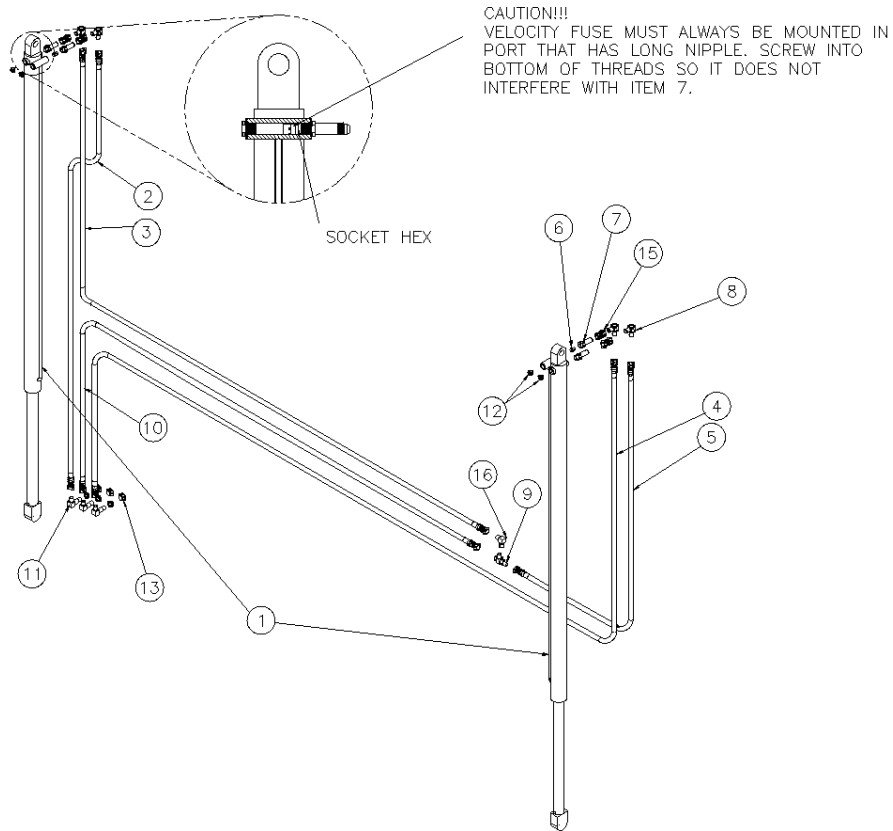

Drawing No.	Gate Width	Qty Req'd	LH "Down" Item 3	RH Lifting Item 4	RH "Down" Item 5	Item 10
CA-820-467	102"	1 ea.	AT-501-365-012	AT-501-354-174	AT-501-354-074	AT-501-354-093
CA-820-466	96"	1 ea.	AT-501-365-011	AT-501-365-014	AT-501-354-074	AT-501-354-089

HYDRAULIC PARTS REPLACEMENT (Cont.)

WARNING! VELOCITY FUSE (HOSE BURST VALVE) MUST BE MOVED FROM OLD TO NEW CYLINDER, WHEN REPLACING LIFT CYLINDER. FAILURE TO FOLLOW THESE INSTRUCTIONS COULD RESULT IN INJURY.

REPLACING LIFT CYLINDER P34101 ON FXD / FDC-CR RAIL GATE

CAUTION!!!
VELOCITY FUSE MUST ALWAYS
BE MOUNTED IN PORT THAT
HAS LONG NIPPLE. REMOVE
VELOCITY FUSE FROM OLD
CYLINDER AND PLACE IN NEW.

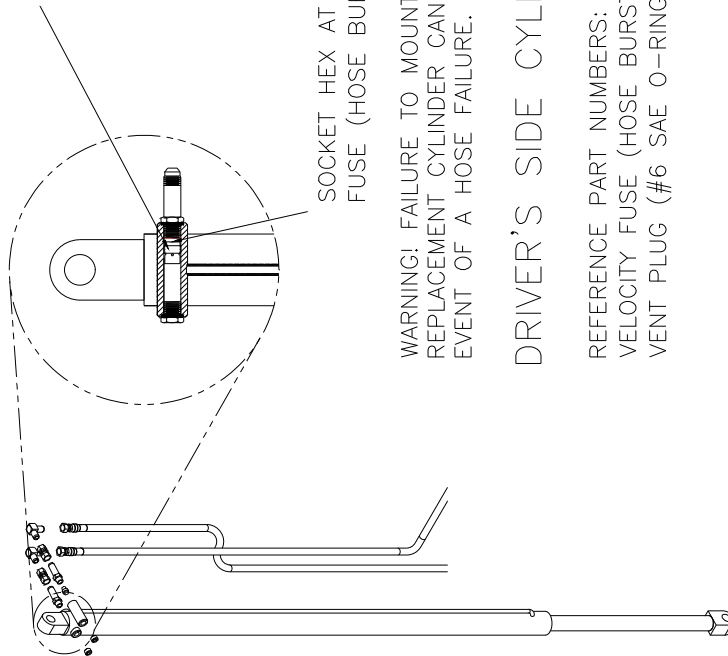

SOCKET HEX AT TOP OF VELOCITY
FUSE (HOSE BURST VALVE).

WARNING! FAILURE TO MOUNT VELOCITY FUSE IN
REPLACEMENT CYLINDER CAN CAUSE INJURY, IN THE
EVENT OF A HOSE FAILURE.

DRIVER'S SIDE CYLINDER SHOWN

REFERENCE PART NUMBERS:

VELOCITY FUSE (HOSE BURST VALVE) P34102

VENT PLUG (#6 SAE O-RING) P34107

CAB20100MAN

POWER FOLD PARTS REPLACEMENT

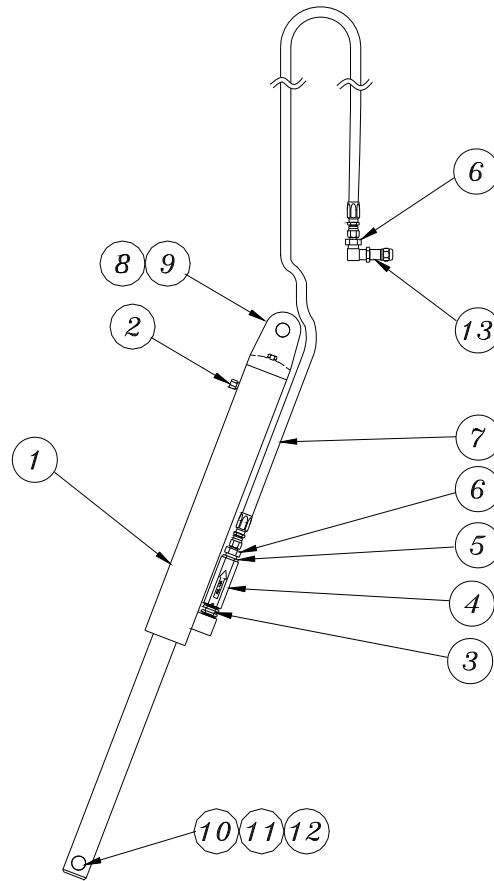

Index No.	Qty Req'd	Part Number	Part Name
1	1	P34108	Hyd. Cylinder
2	1	P33646	Breather Vent – 3/8 NPT
3	1	P34050	Straight Nipple
4	1	P34179	Flow Control Valve – STEEL PLATFORM
4	1	P34159	Flow Control Valve – ALUM. PLATFORM
5	1	P34044	Straight Nipple
6	2	P34110	Adapter
7	1	AT-501-410-079	Hose Assembly (with Spring Guard)
8	1	AP-820-097	Top Ram Pin
9	2	P24019	Retaining Ring
10	1	S754-005.500	Bottom Ram Mtg Pin – STEEL PLATFORM
10	1	AP-451-945	Bottom Ram Mtg Pin – ALUM. PLATFORM
11	1	P47532	Roll Pin – STEEL PLATFORM
11	1	P47538	Roll Pin – ALUM. PLATFORM
12	2	P26019	Washer
13	1	P34106	Bulkhead Elbow

REPLACEMENT ROLLER

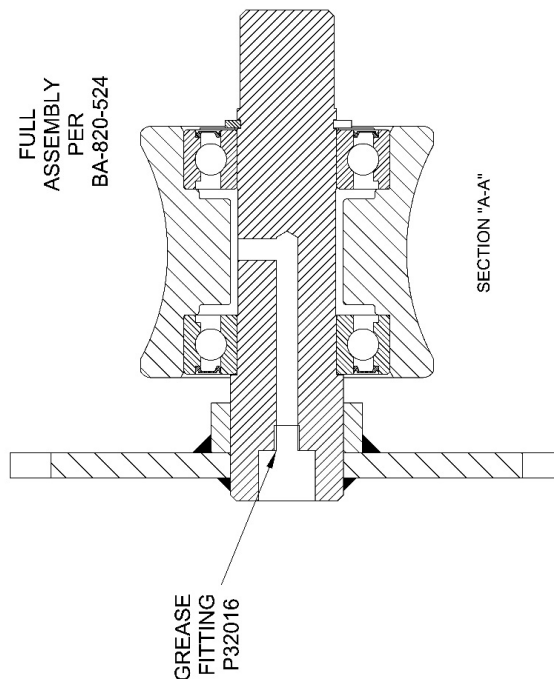
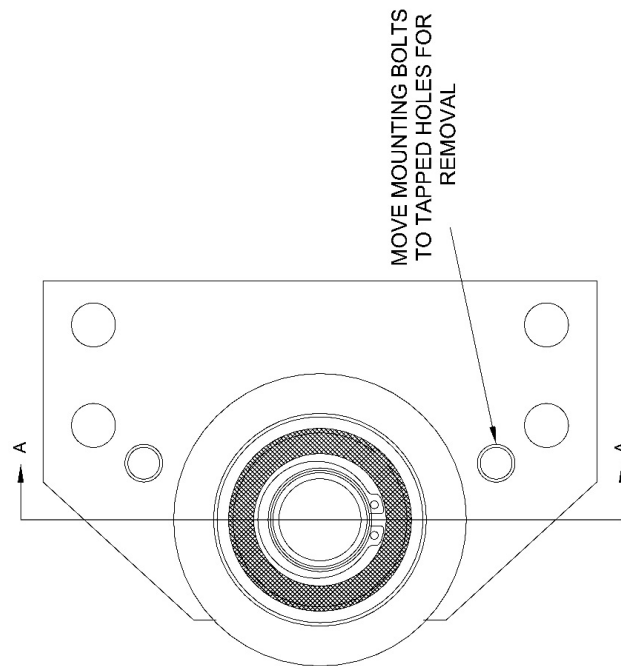

REPLACEMENT ROLLER IS ONLY SOLD AS A COMPLETE ASSEMBLY UNDER PART NO. BA-820-524. SPECIAL EQUIPMENT IS REQUIRED TO MOUNT BEARINGS ON ROLLER AND SHAFT TO AVOID BEARING DAMAGE. THIS CAN ONLY BE PROPERLY DONE AT OUR FACTORY.

PLATFORM PINS AND BUSHINGS

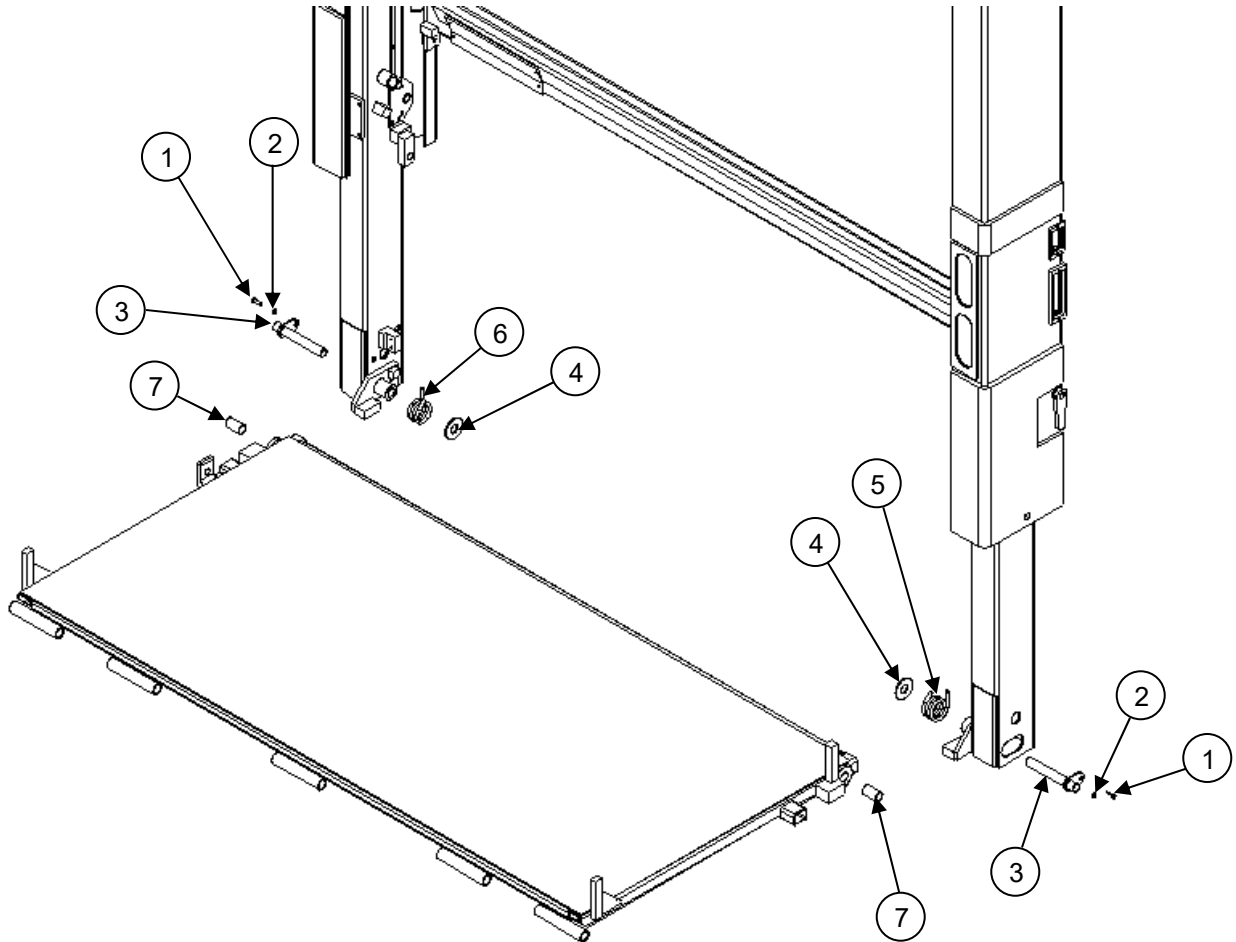

Index No.	Qty.	Part Number	Part Name	Material Size/Notes
1	2	P11021	Bolt	3/8-16 x 1 G5
2	2	P26017	Washer Lock Split 3/8	WASHER LOCK SPLIT 3/8
3	2	BA-820-264	Shaft Assembly	
4	6	P26521	Spacer Washer	1"
5	1	P25217	Torsion Spring RH	
6	1	P25218	Torsion Spring LH	
7	2	P43578	Platform Bearing	

WALK AROUND ELECTRICS

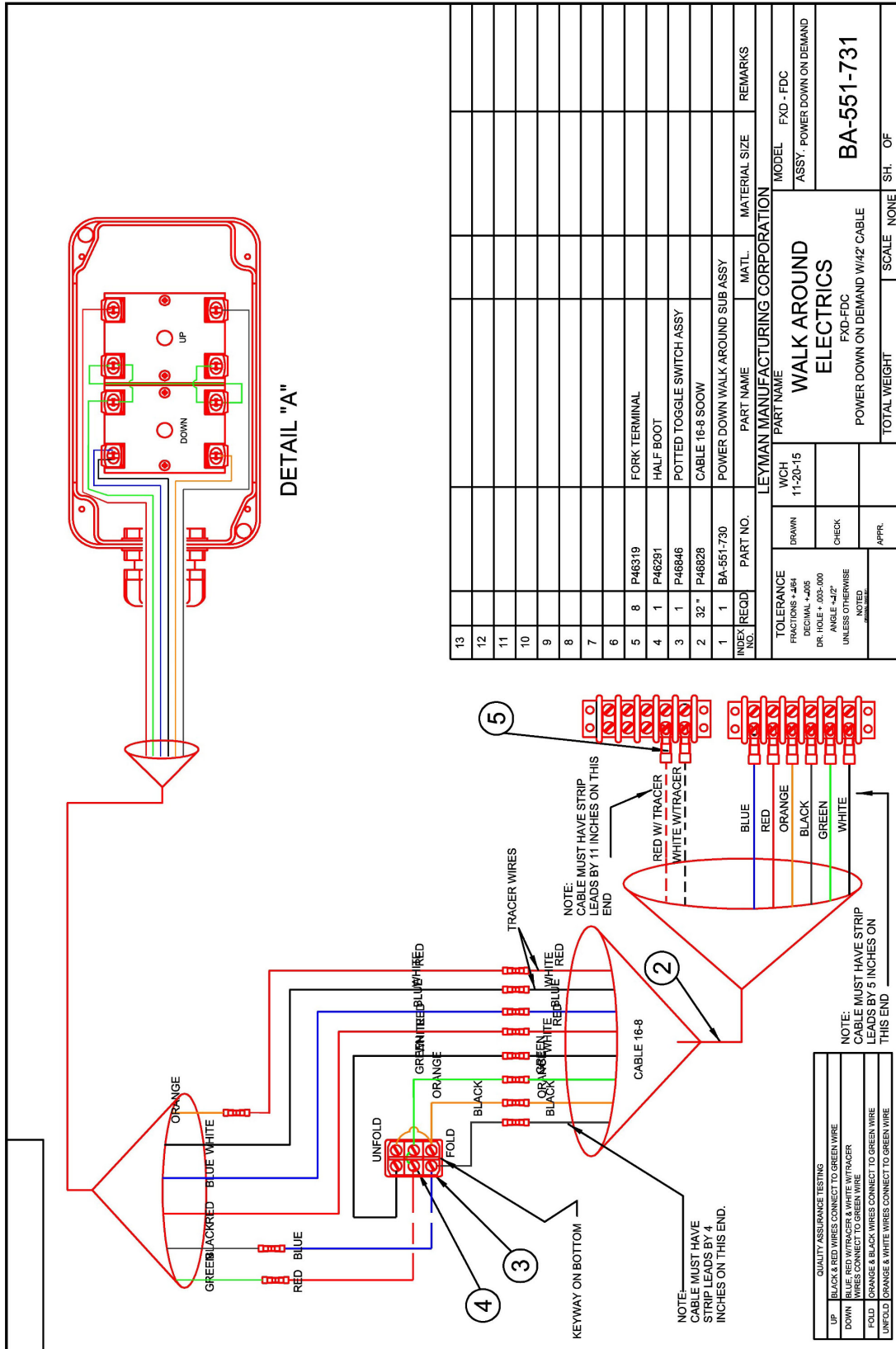

SWITCH WIRING

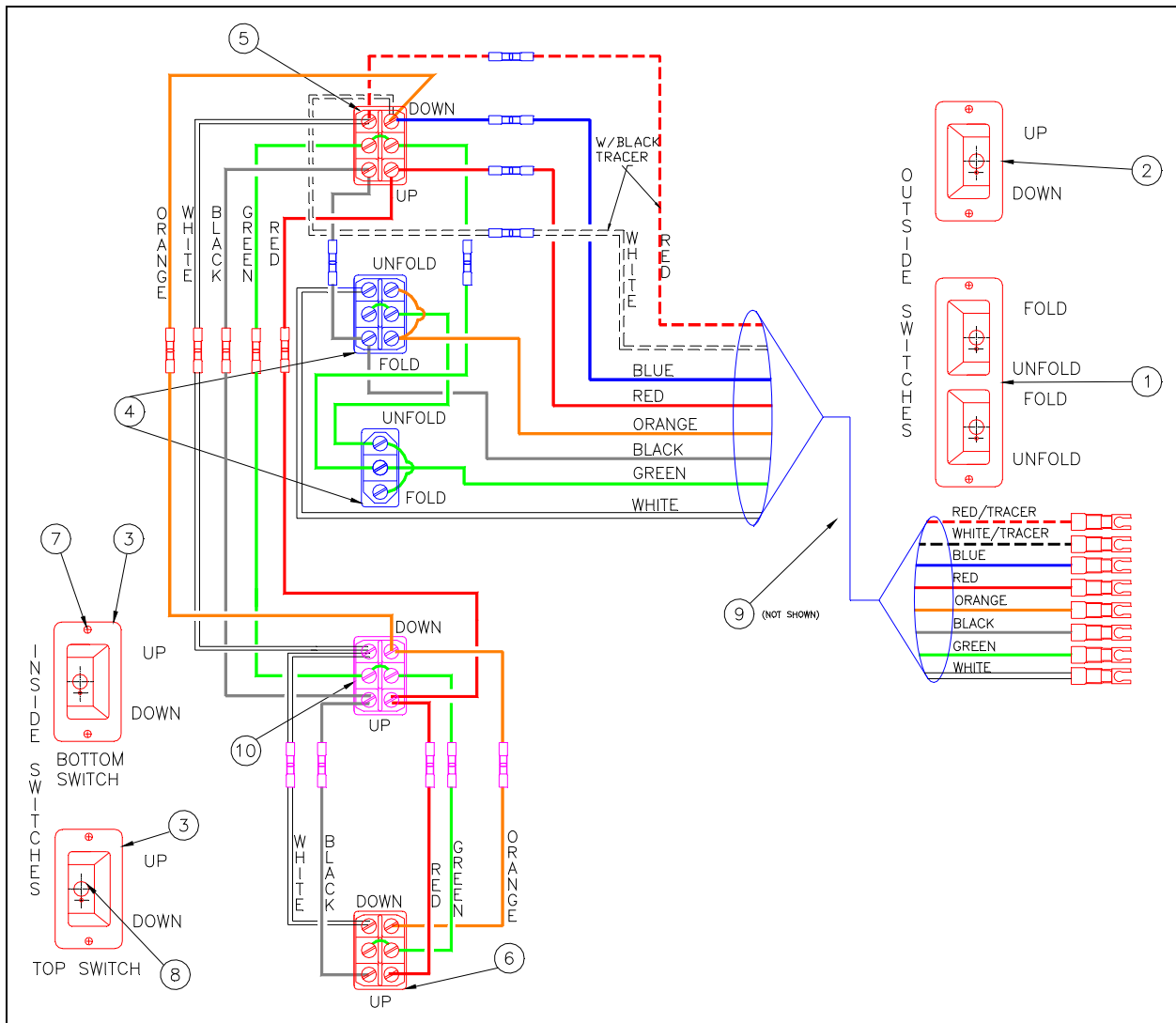

Index No.	QTY	Part Number	Part Name	Description
1	1	BP-820-134	Recessed Switch Plate	Double switch – Fold/Unfold
2	1	BP-820-198	Recessed Switch Plate	Single switch – outer
3	2	BP-820-133	Recessed Switch Plate	Single switch – inner
4	1	AA-551-766	Replacement switch assy DBL.	Outer Fold/Unfold Double Switch
5	1	AA-551-764	Replacement switch assy SGL	Outer Up/Down Single Switch
6	1	AA-551-765	Replacement switch assy SGL	Upper Inner Up/Down Switch
7	6	P19527	Button head cap screw	#10-24 x 3/8
8	3	P46291	Rubber Boot	
9	1	P46445	Cord Grip	1/2 .5-.6 grip range
10	1	AA-551-763	Replacement switch assy SGL	Lower Inner Up/Down Switch

POWER UNIT PARTS

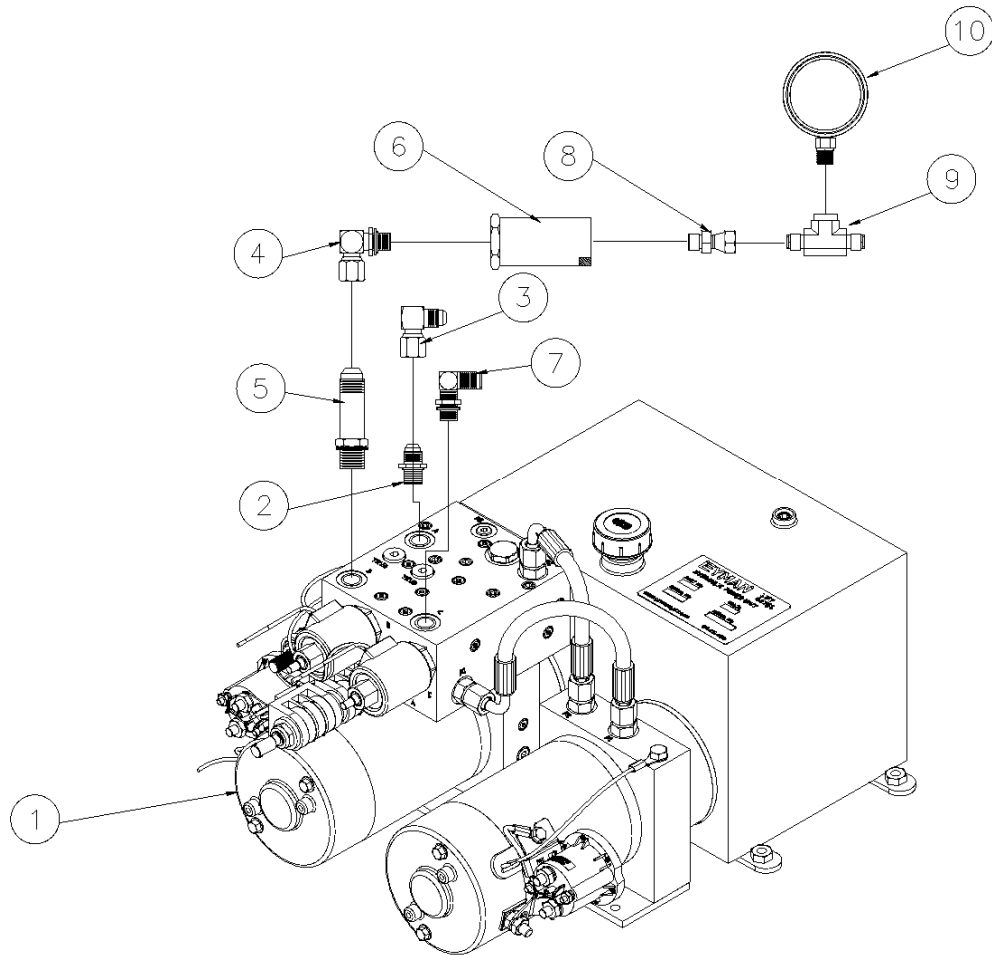

10	1	P34242	PRESSURE GAUGE				
9	1	P34243	TEE		9/16-18 X 9/16-18 X 1/4-18		
8	1	P34042	ADAPTER		9/16 SAE 37 DEG FEMALE TO 9/16 SAE ORB MALE		
7	1	P34020	ELBOW		90 DEG ELB SAE O-RING - 9/16 18M 37 DEG		
6	1	P34046	FILTER				
5	1	P34103	LONG NIPPLE		9/16-18SAEORB M -9/16-18JIC M		
4	1	P34045	ADAPTER		9/16 SAE 37 DEG (F) - TO 9/16 SAE ORB (M)		
3	1	P34051	ELBOW		9/16-18 JIC(M) - 9/16-18 JIC (F)		
2	1	P34044	ADAPTER		9/16 SAE ORB(M) -9/16 JIC (M)		
1	1	P34218	MTE HYDRAULIC PWR UNIT				
INDEX NO.	REQD	PART NO.	PART NAME	MATL.	MATERIAL SIZE	REMARKS	WGT.

POWER UNIT PARTS

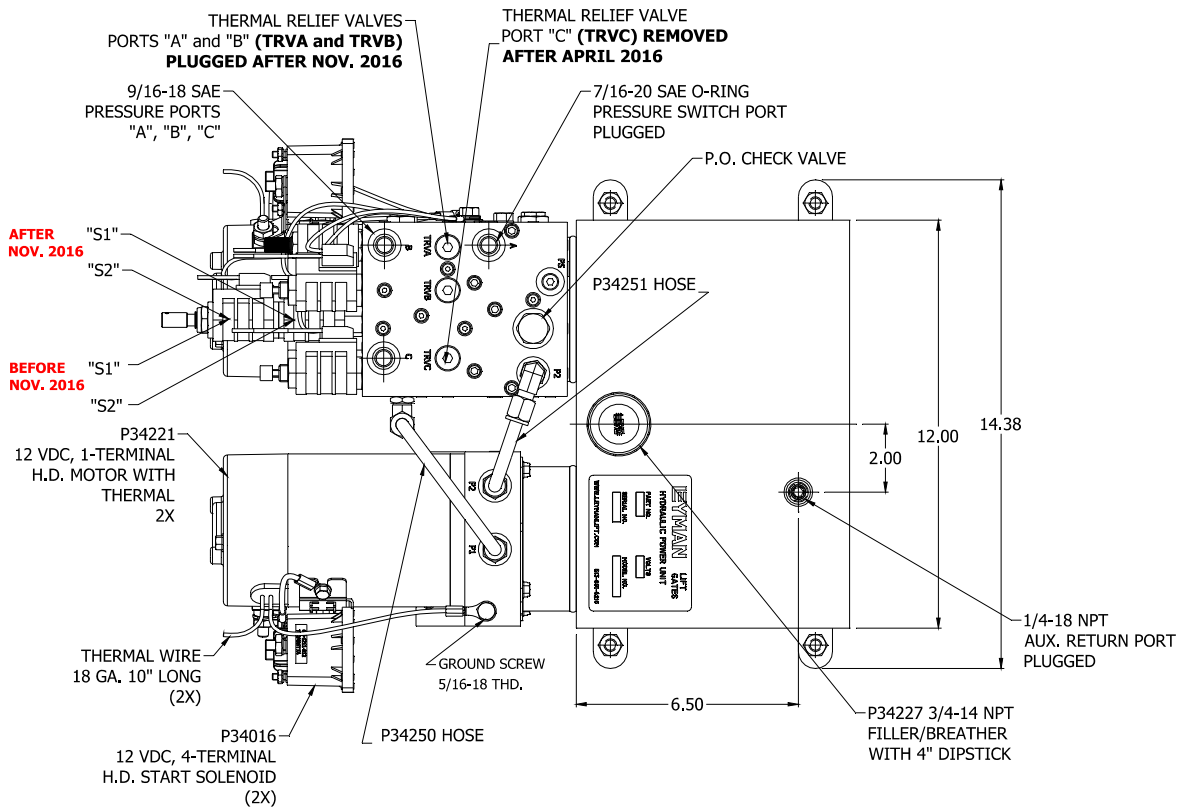

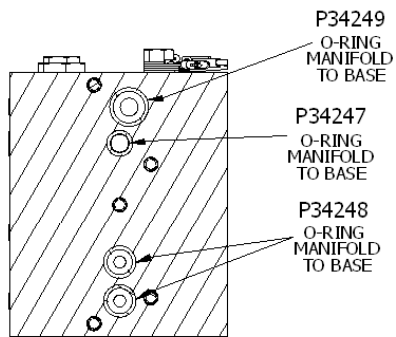
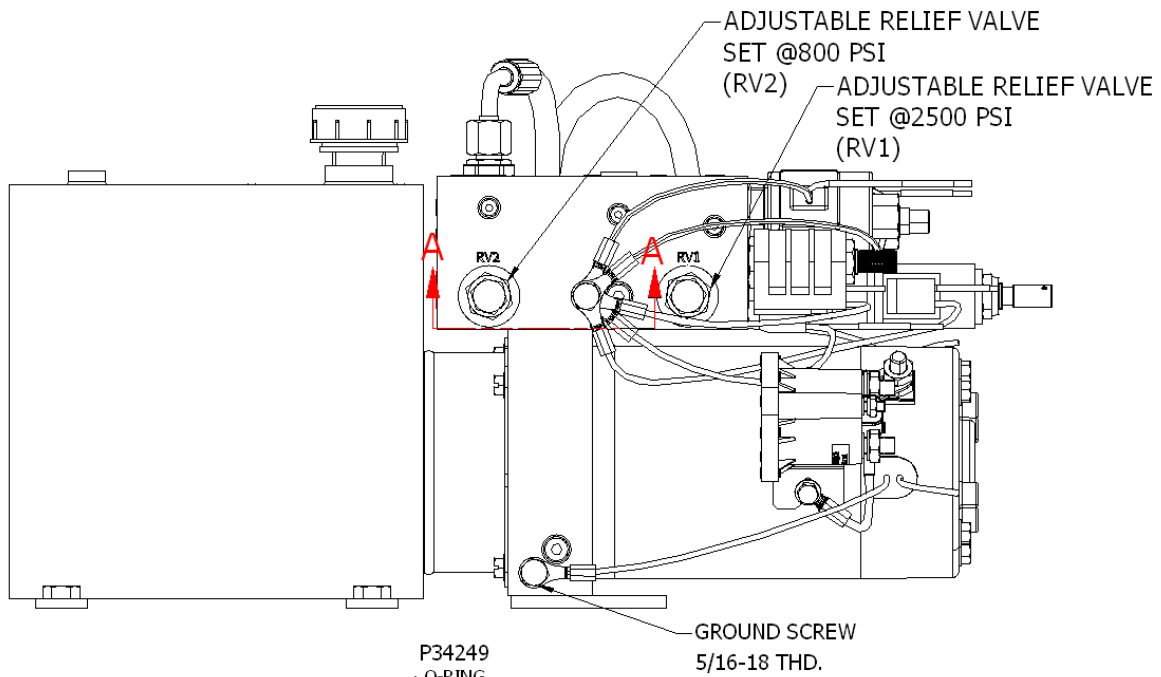

SECTION A-A

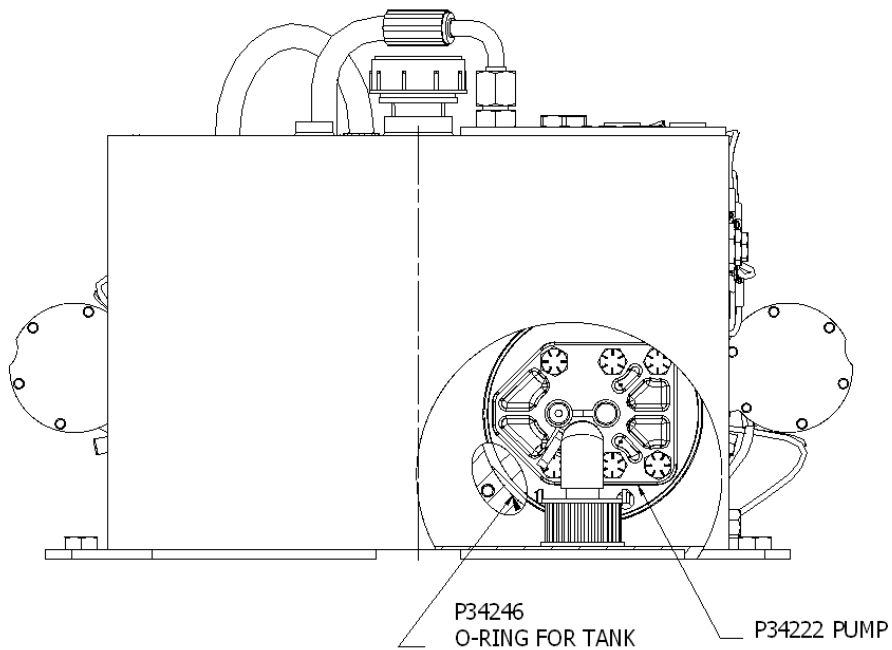

BEFORE NOVEMBER 2016:

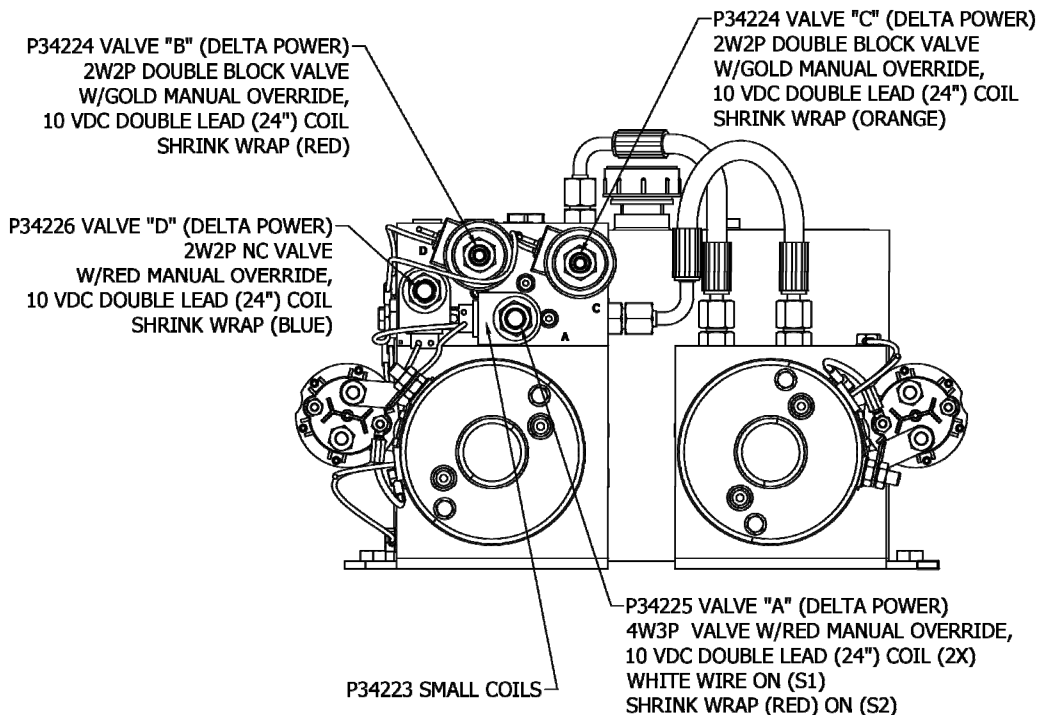

AFTER NOVEMBER 2016:

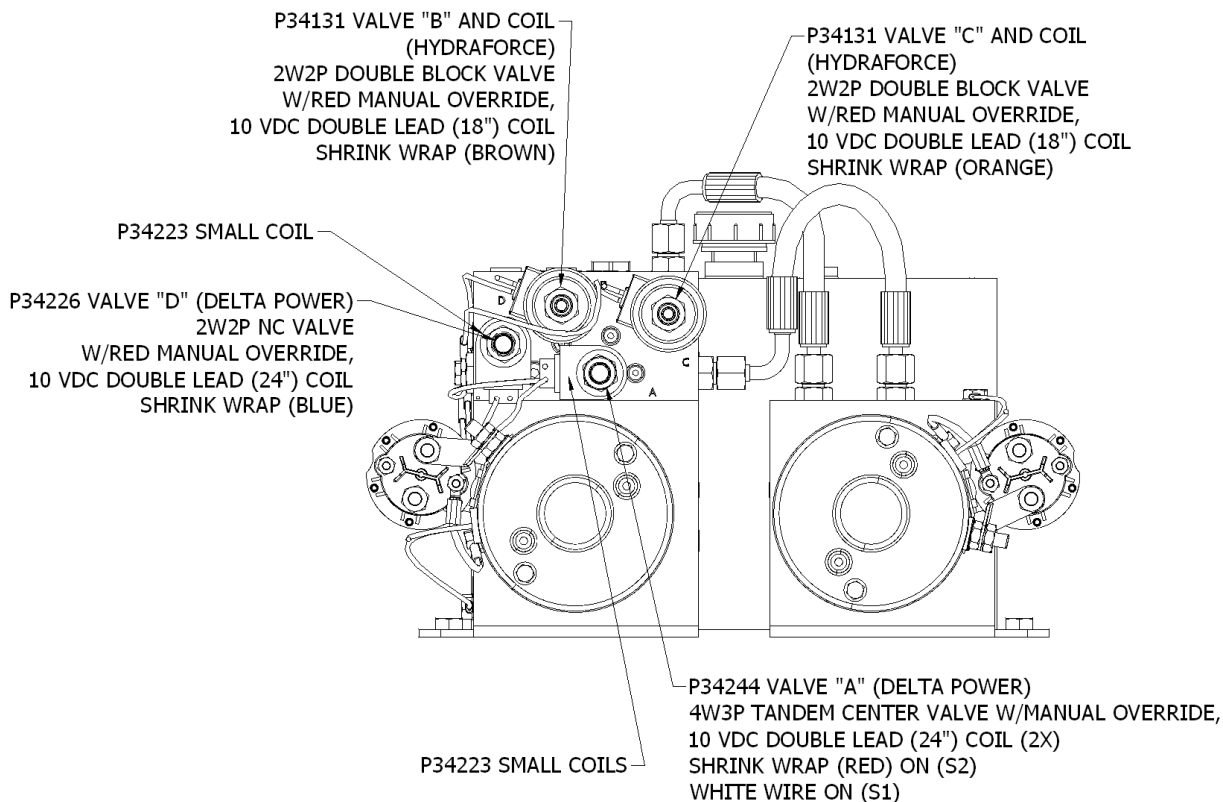

POWER UNIT ASSEMBLY

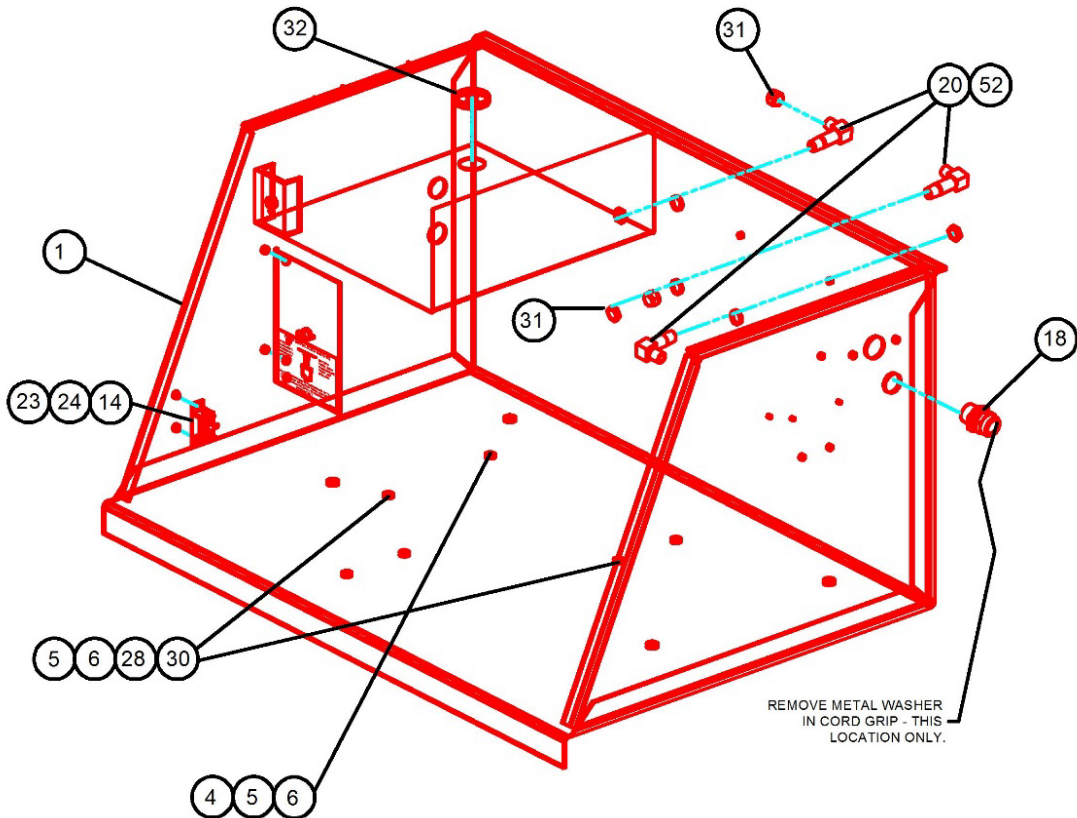
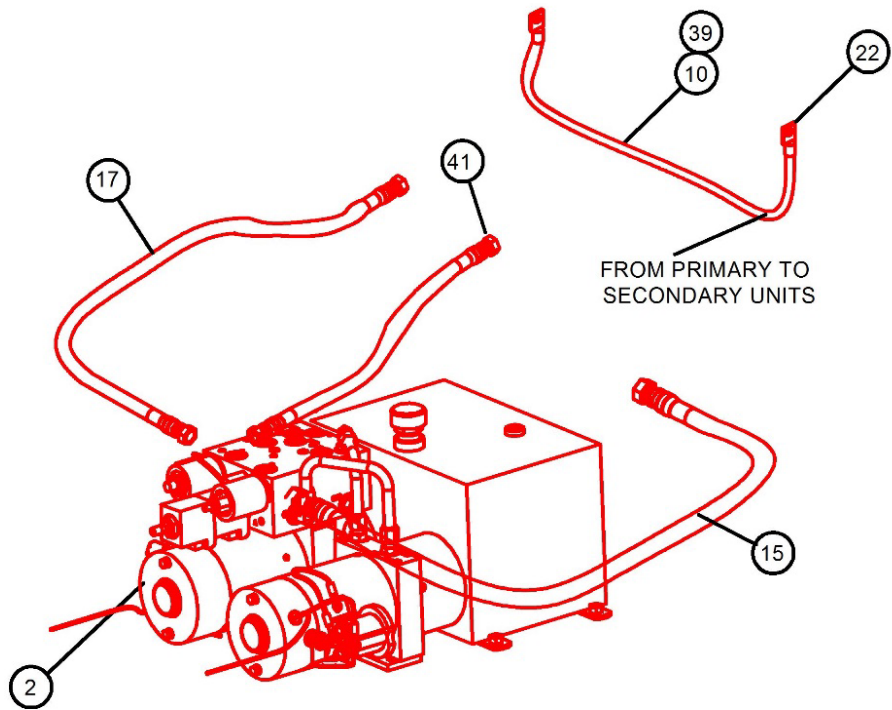

POWER UNIT ASSEMBLY

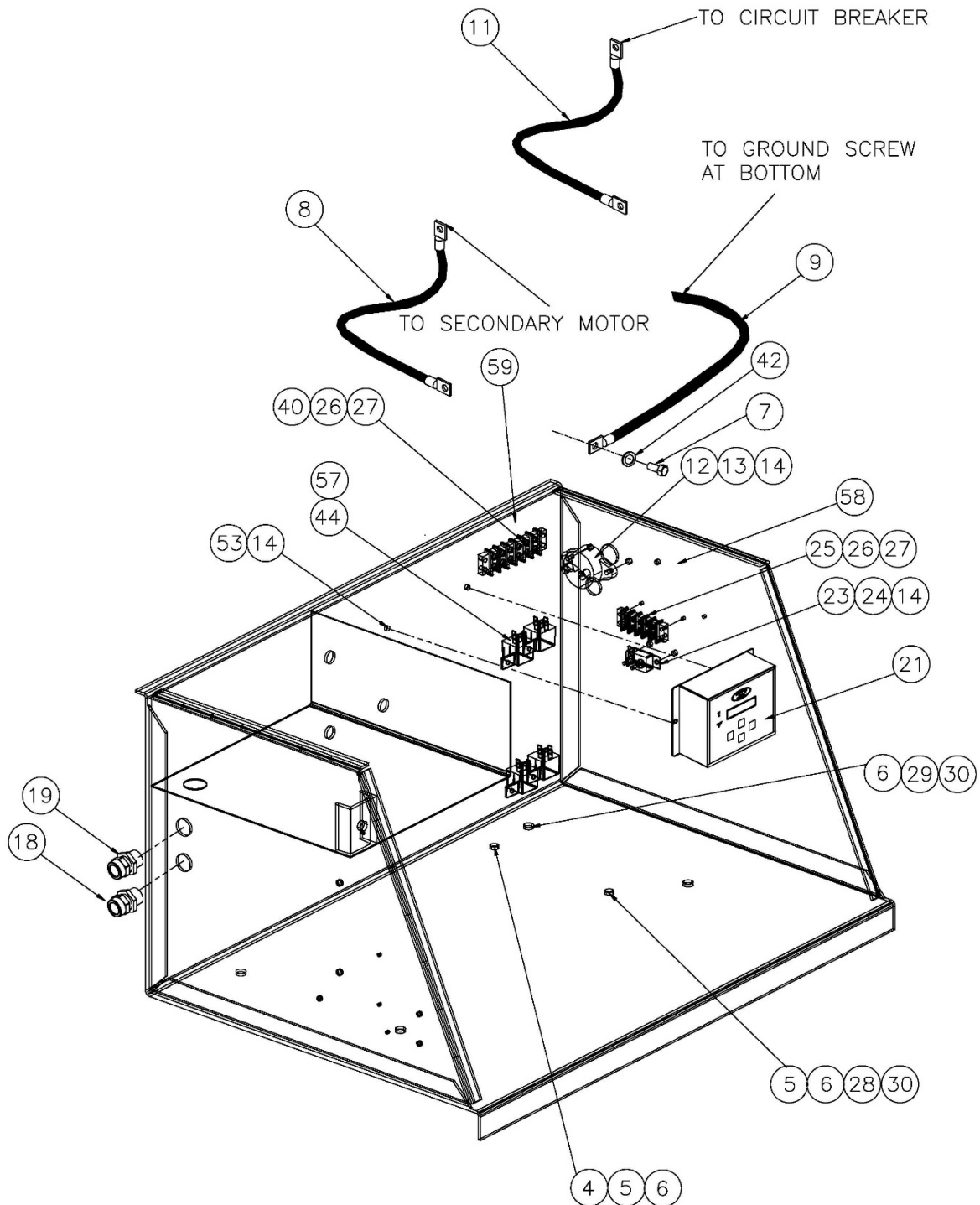

Index No.	QTY	Part Number	Part Name	Description
1	REF	CA-501-377	ENCLOSURE ASSY	
2	1	CA-501-468	POWER UNIT ASSEMBLY	
3				NOT REFERENCED
4	2	P11048	HEX BOLT	3/8-16 X 1-1/4 GR-8 PLATED
5	7	P26017	SPLIT LOCK WASHER	3/8
6	11	P26501	FLAT WASHER	3/8
7	1	P10534	HEX HEAD CAP SCREW	5/16-18 X 3/4
8	1	P46127	BATTERY CABLE - RED	21 IN.
9	1	P46627	BATTERY CABLE - BLACK	12 IN.
10	1	P46127	BATTERY CABLE - RED	26 IN.
11	1	P46127	BATTERY CABLE - RED	12 IN.
12	1	P46864	CIRCUIT BREAKER	150 AMP.
13	2	P18519	SCREW	10-24 X 1
14	8	P23504	LOCK NUT	10-24
15	1	AT-501-354-027	HYDRAULIC HOSE ASSY	UP PORT
16	8	P46279	HEAT SHRINK TUBE	8 PCS – 1 IN. LONG
17	1	AT-501-354-024	HYDRAULIC HOSE ASSY	FOLD PORT
18	2	P46139	CORD GRIP	.4 - .5 GRIP RANGE
19	1	P46445	CORD GRIP	.5 - .6 GRIP RANGE
20	3	P34106	BULKHEAD ELBOW	9/16-18 JIC BOTH ENDS
21	1	P46608H	MAINTENANCE MINDER	PROGRAMMING REQ'D BEFORE SHIPPING
22	8	P46403	BATTERY TERMINAL	4 GA. CRIMP LUG
23	2	P46236	20 AMP CIRCUIT BREAKER	
24	4	P19501	RD HD MACHINE SCREW	10-24 X 1/2
25	1	P46474	TERMINAL BLOCK	
26	4	P19519	RD HD MACHINE SCREW	6-32 X 3/4
27	4	P23535	NYLON INSERT LOCK NUT	6-32
28	6	P11021	BOLT	3/8-16 X 1 GR. 5
29	1	P23538	HEX NUT	3/8-16
30	4	P23501	LOCK NUT	3/8-16
31	2	P34004	CAP NUT 9/16-18 37 DEG	
32	1	P25053	GROMMET	
33	1	CA-551-737	POWER UNIT ELECTRICS ASSY	
34	1	P55337	IMPORTANT INSTRUCT. DECAL	
35	1	P55338	FAULT CODES DECAL	
36	1	P48007	FOAM TAPE	122 IN. LONG
37	1	BA-551-731	WALK AROUND ELECTRICS	W/24FT CABLE
38	1	P55456	ELEC./HYDRAULIC DIAGRAM	
39	1	P46485	1/2 IN SPLIT NYLON LOOM	26 IN.
40	1	P46449	TERMINAL BLOCK	
41	1	AT-501-354-020	HYDRAULIC HOSE ASSY	DOWN PORT
42	1	P27027	LOCK WASHER	5/16
43	1	P55454	GENERAL TIPS DECAL	
44	4	P46487	RELAY	
				ITEMS 45 – 48 NOT REFERENCED
49	1	P55185	FOLD/UNFOLD DECAL	
				ITEMS 50 – 51 NOT REFERENCED
52	3	P26004	FLAT WASHER	1/2"
53	2	P19534	RD HD MACHINE SCREW	10-24 X 3/4
				ITEMS 54 – 55 NOT REFERENCED
56	4	P46818	LOOM CLAMP	1" TO SECURE WIRE BUNDLE
57	4	P17518	SELF TAPPING SCREW	
58	1	P55462	SHORT TERM. STRIP DECAL	
59	1	P55461	LONG TERM. STRIP DECAL	

Adjustable Flow Control Valve in Folding Line (if equipped)

Flow adjustment can be made under pressure. Setting knob can be locked in any desired position with convenient set screw.

Turn knob clockwise to decrease speed when closing platform or turn knob counterclockwise to increase speed when closing platform.

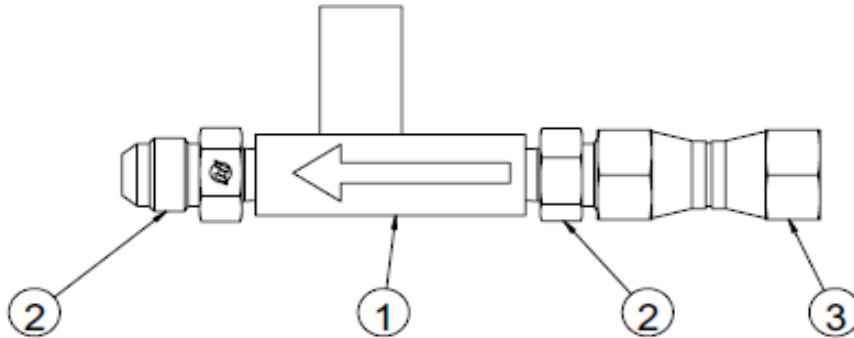

NOTES

- 1.- ADD NPT SEALER BETWEEN ITEMS 1 AND 2.
- 2.- ITEM 3 CONNECTS TO EXISTING FOLD FITTING FROM POWER UNIT. REUTILIZE EXISTING HOSE.

Item No.	Qty	Part	Description
1	1	P34270	ADJ. FLOW CONTROL VALVE
2	2	P34269	STRAIGHT ADAPTER
3	1	P34058	STR ADAPTER 9/16-18 FEMALE

DIVIDER VALVE / FLOW CONTROLS (Before 7-2017)

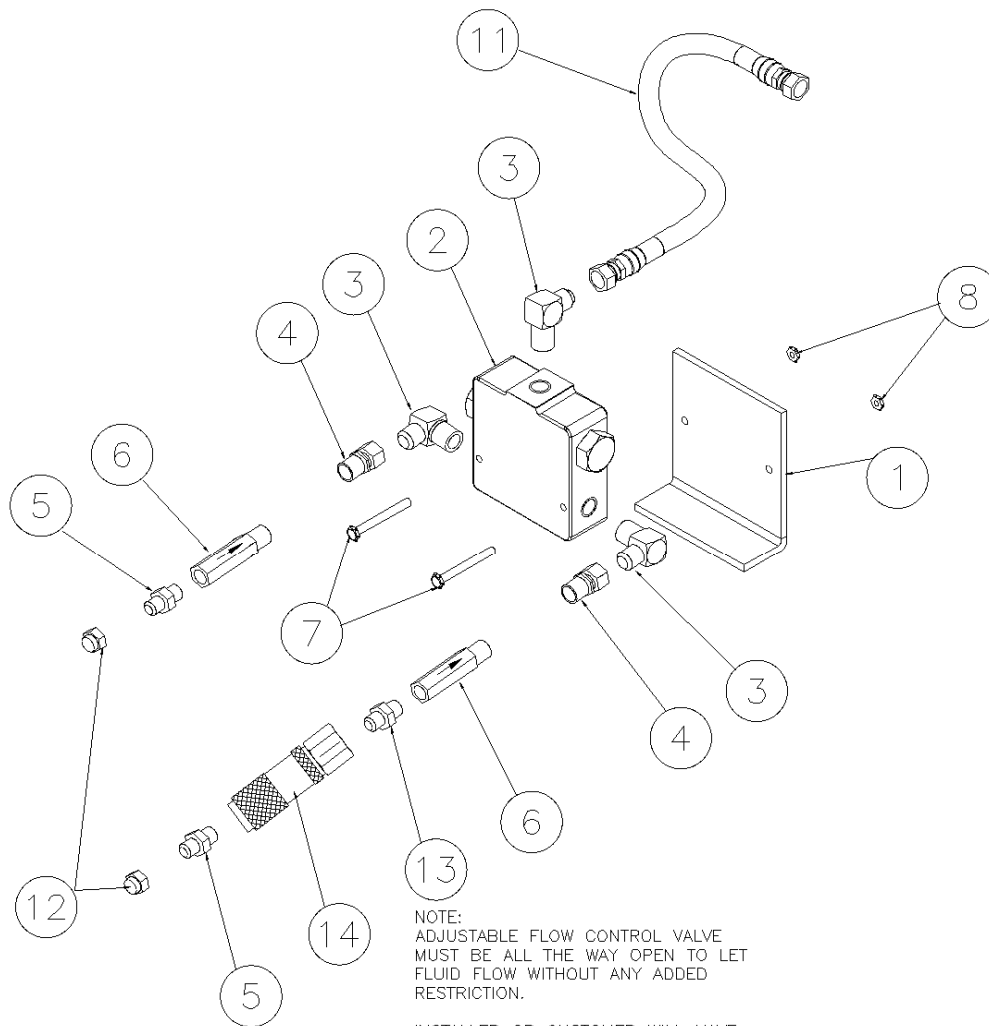

NOTE:
ADJUSTABLE FLOW CONTROL VALVE
MUST BE ALL THE WAY OPEN TO LET
FLUID FLOW WITHOUT ANY ADDED
RESTRICTION.

INSTALLER OR CUSTOMER WILL HAVE
THE LIBERTY TO ADJUST IT AS WELL AS
TO SWITCH IT TO THE OTHER SIDE OF
THE DIVIDER IF NEEDED.

Index No.	QTY	Part Number	Part Name	Description
1	1	AP-811-718	Equalizer MTG Bracket	Ref. only
2	1	P33547H	Equalizer Valve	
3	3	P34128	Elbow	9/16-18 JIC M -3/4-16 ORB(M)
4	2	P34042	Adapter	9/16-18 JIC F to 9/16 SAE ORB M
5	2	P34044	Adapter	9/16 SAE ORB M to 9/16-18 JIC M
6	2	P34159	Flow Control 2.8 GPM	SAE O-ring F, Matched Pair
7	2	P10508	Bolt	1/4-20 x 2-1/2
8	2	P23502	Lock Nut	1/4-20
9				
10				
11	1	AT-501-354-013	Hyd. Hose assembly	
12	2	P34004	Cap Nut	
13	1	P34050	Straight Nipple	9/16 SAE ORB M to 9/16 SAE ORB M
14	1	P34189	Adj. Inline Flow Control	0.5 to 6.0 GPM

DIVIDER VALVE / FLOW CONTROLS (After 7-2017)

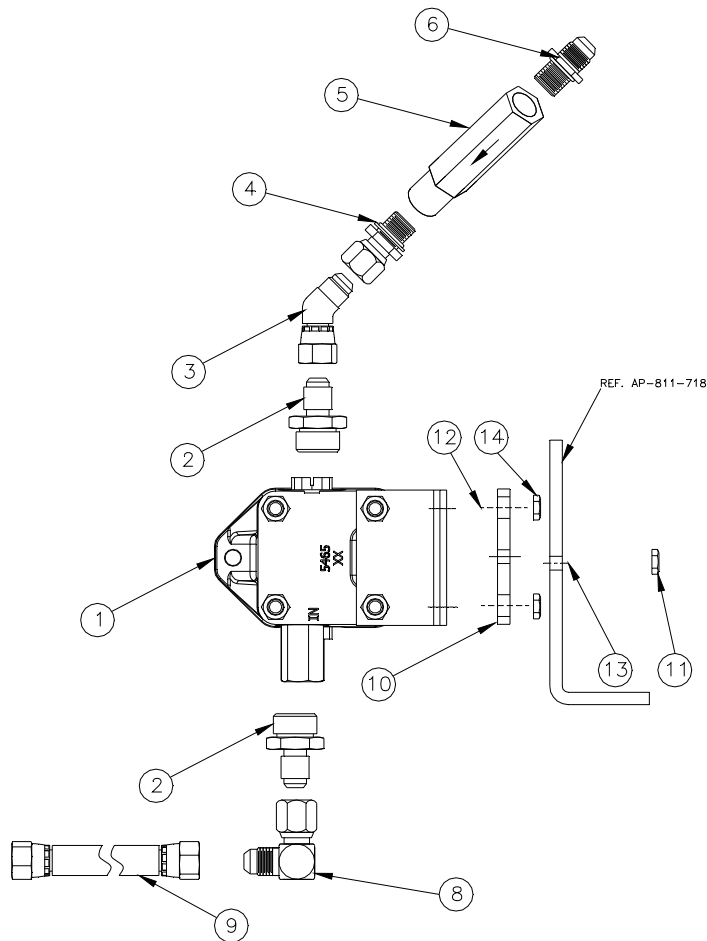

Index No.	QTY	Part Number	Part Name	Description
1	1	P34238	Gear Divider Valve	
2	3	P34240	Straight Adapter Fitting	9/16 MALE JIC X 7/8-14 MALE SAE
3	2	P34228	45° Elbow	
4	2	P34042	Straight Adapter Fitting	9/16 Female JIC to 9/16 Male SAE
5	2	P34159	Flow Control	2.8 GPM
6	2	P34044	Straight Adapter Fitting	9/16 Male JIC to 9/16 Male SAE
8	1	P34051	90° Elbow	9/16 Male JIC to 9/16 Female JIC
9	1	AT-501-354-020	Hyd. Line Assy	20" w/JIC ends
10	1	AP-820-544	Divider Valve Mtg Bracket	
11	2	P23502	Lock Nut	1/4-20
12	4	P11072	Bolt	3/8-16 x 1
13	2	P11073	Bolt	1/4-20 x 1
14	4	P23546	Lock Nut	3/8-16 Large Flange

SAFETY WARNING SIGNS / DECALS

STREET SIDE DECALS

**Warning Signs and Decals will be replaced at any time
FREE OF CHARGE**

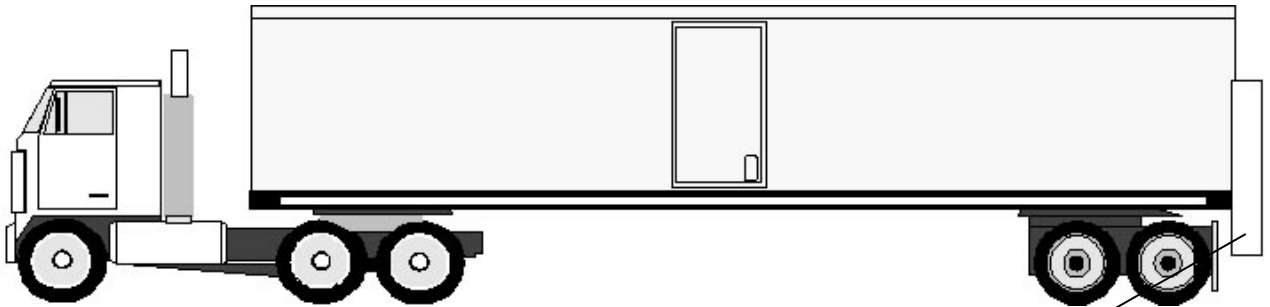

Will receive two of these decals. One goes
on each side at bottom of Outer Mast

P55295

SAFETY WARNING SIGNS / DECALS

CURB SIDE DECALS

**Warning Signs and Decals will be replaced at any time
FREE OF CHARGE**

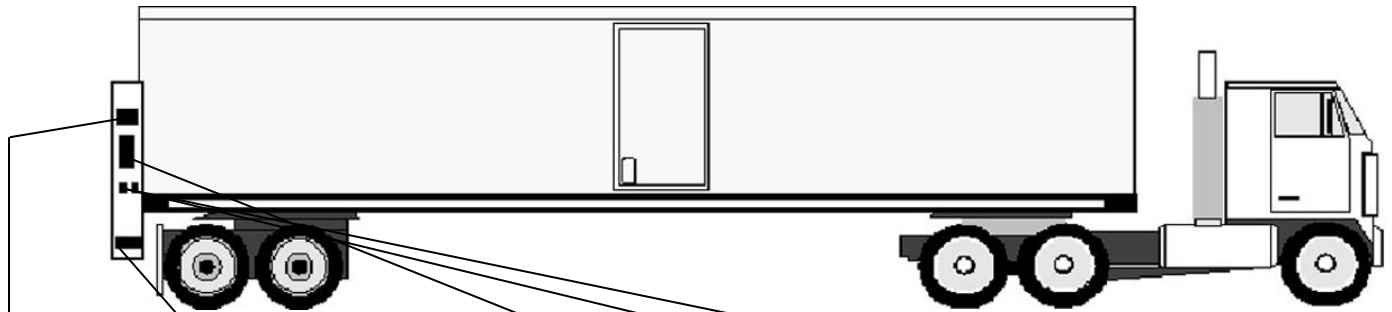

P55295

CAUTION

**DO NOT STAND BEHIND
VEHICLE WHEN OPENING AND OPERATING!
USE SAFETY CART STOP.**

LEYMAN MANUFACTURING CORP. CINCINNATI OHIO

THE SURFACE TO WHICH THIS LABEL IS TO BE APPLIED MUST BE FREE FROM OIL, GREASE AND OTHER CONTAMINANTS.
Read all decal and warning labels. Apply with the finger pressure.
FORM 10001 - 10/06, P.O. Box 10000, CINCINNATI, OH 45227

URGENT WARNING
ELEVATING GATE INSTRUCTIONS
Before Operating Lift, Be Sure You Understand

- Improper operation of this lift can result in serious personal injury. Do not operate unless you have been properly instructed and have read, and are familiar with, the operating instructions. If you do not have a copy of the instructions please obtain them from your employer, distributor, or lessor, as appropriate, before you attempt to operate the lift.
- Be certain the vehicle is properly and securely braked before using the lift.
- Always inspect this lift for maintenance or damage before using it. If there are signs of improper maintenance, damage to vital parts, or slippery platform surfaces, do not use the lift. Do not attempt your own repairs, unless you are specifically trained.
- Do not overload. See the Mfg. Literature and/or Rating Label on the unit for the rated load. Remember that this limit applies to both raising and lowering operations.
- Each load should be placed in a stable position as near as possible to the center of the platform.
- Never stand in or more through or allow anyone else to stand in or move through the area in which the lift may operate or into which an upset load might fall.

P55157

Mount one Max. Cap. decal on outside of Outer Mast near switches. Mount other Max. Cap. decal on Inner Mast just above chain anchor.

OPERATING INSTRUCTIONS
CAUTION

BEFORE OPERATING THE LIFT, READ AND UNDERSTAND THIS DECAL, URGENT WARNING DECAL AND OWNER'S MANUAL.

DO NOT STAND BEHIND LIFT GATE WHILE UNFOLDING OR USING PLATFORM.

TO UNFOLD PLATFORM FROM OVER-THE-ROAD POSITION

- MOMENTARILY FOLD GATE. PUSH THE FOLD AND UP SWITCHES AT THE SAME TIME, AS TO ENSURE GATE IS FULLY FOLDED.
- TO RELIEVE TENSION ON AUTO LOCK, PUSH THE UP SWITCH (GATE WILL GO UP), PULL HANDLE TO RELEASE AUTO LOCK.
- LOWER PLATFORM BY PUSHING DOWN SWITCH SO EARS ARE BELOW THE SAFETY PLATE ON OUTER MAST.
- PUSH THE UNFOLD SWITCH, GATE WILL UNFOLD.

TO DOCK LOAD

- TO RELIEVE TENSION ON AUTO LOCK, PUSH THE UP SWITCH (GATE WILL GO UP), PULL HANDLE TO RELEASE AUTO LOCK.
- LOWER GATE UNTIL EARS ON PLATFORM REST ON STOPS OF OUTER MAST.

TO LOWER PLATFORM, USE DOWN SWITCH ONLY.
TO RAISE PLATFORM, USE UP SWITCH ONLY.

SAFE LOADING OF PLATFORM

- CART STOP OR RETENTION RAMP MUST BE IN PLACE WHENEVER LIFTING OR LOWERING A LOAD. ALSO SEE URGENT WARNING DECAL.

TO FOLD PLATFORM

- RAISE PLATFORM OFF GROUND SO EARS ARE ABOVE THE SAFETY PLATE ON OUTER MAST WHEN PLATFORM FOLDS.
- PUSH THE FOLD AND UP SWITCH AT THE SAME TIME BY USING BOTH HANDS. PLATFORM WILL FOLD. CONTINUE TO RAISE PLATFORM TO THE FULL UP POSITION. AUTO LOCK WILL LATCH.

LEYMAN MANUFACTURING CORPORATION
CINCINNATI, OH 45240 P55214
PHONE: (513) 891-6210

P55433

**6800 lb.
MAXIMUM
CAPACITY**

P55432

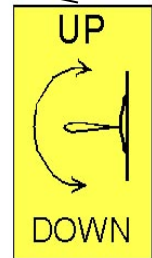
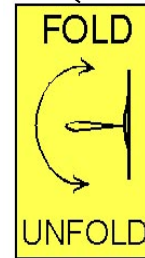

Mount each decal next to the corresponding toggle switch. Make sure you mount three UP / DOWN decals (two on the inside of the Outer Mast). Mount two FOLD / UNFOLD decals (next to the dual switch plate).

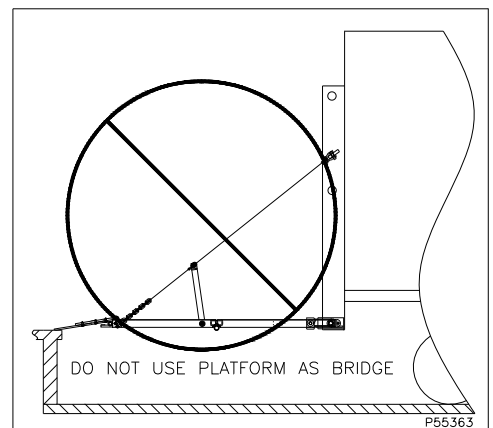

SAFETY WARNING SIGNS / DECALS

REAR OF VEHICLE DECALS

**Warning Signs and Decals will be replaced at any time
FREE OF CHARGE**



Mount P55309 on each outer mast

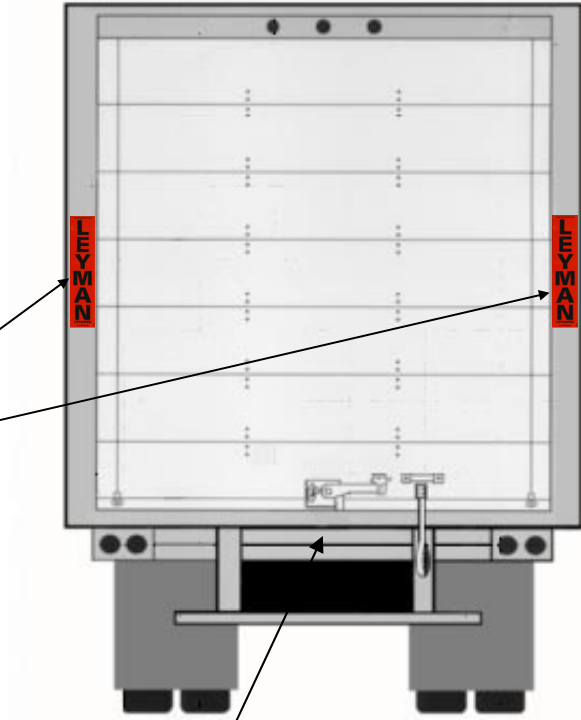

P55138

Decal Part Numbers not listed on diagrams:

- | | | | |
|--------------------------|--------|--------------------|--------|
| (2) 6800 MAX CAP | P55432 | (3) FOLD / UNFOLD | P55185 |
| (3) UP / DOWN | P55221 | (1) URGENT WARNING | P55157 |
| (1) DO NOT USE AS BRIDGE | P55363 | | |

MODEL AND SERIAL NUMBER TAGS

Serial No. is also located in MENU 1 of Maintenance Minder 2®

Serial number tag is located inside power unit box.

LEYMAN  LIFT GATES	
10900 KENWOOD ROAD CINCINNATI, OHIO 45242 513-891-6210 WWW.LEYMANLIFT.COM	
MODEL	FXD68DED-8684RR
SERIAL NO.	289999
CAPACITY	6800 lbs.
MANUFACTURE DATE	08-14-08

Model number tag is located on the left-hand Outer Mast.

LEYMAN  LIFT GATES	
10900 KENWOOD ROAD CINCINNATI, OHIO 45242 513-891-6210 WWW.LEYMANLIFT.COM	
MODEL	FXD68DED-8684RR
CAPACITY	6800 lbs.
MANUFACTURE DATE	08-14-08
PATENTS PENDING	

