



**[ LHLP ]** **HIDE-A-WAY®**  
**TUCKUNDER LIFT**

**LIFTING CAPACITY** Up to **5,500 LBS.**

- Designed to Reduce Road Calls
- Built to Last

LHLP FEATURES	BENEFITS
Level Ride Lift Gate	Provides a Level Working Environment for Driver and Freight
Power Down On Demand	Offers Options to Lower Platform (LHLP4500/LHLP5500 Only)
Aluminum Platform	Inhibits Rust While Reducing Weight
Foot Operated Cart Stops x 2	Increases Safety by Reducing Accidents
Low P.S.I. Due to Larger Piston Area	Creates Lower Pressure, Reduces Wear and Extends Motor Life
Adjusts to Different Chassis Widths	Allows Flexibility of Vehicle Installation Options
Pressure Compensated Flow Control	Steady Hydraulic Pressure for Smooth Operation
Bolt-On Power Pack Enclosure Holds Pump and Motor	Easy Installation and Protection from Moisture
Marine Potted Switches	Watertight Switches – Reduces Electrical Failure
Spring Assisted Opening and Closing	Ease of Use and Reduces Physical Effort to Operate
Maintenance Minder2	Measures and Records Lift Gate Operating Data (LHLP4500/LHLP5500 Standard)

# LEYMAN

## LIFT GATES

DELIVERS DEPENDABILITY

# LHLP

Level Ride Aluminum  
Tuckunder Platform



### LHLP Technical Specs

Model Number	Vehicle Width	Lifting Capacity	Platform Size		Approx. Weight
			W"	D"	
LHLP 5500G	96" 102"	5,500 lbs.	86"	60"	1,150 lbs
LHLP 4500G		4,500 lbs.			1,000 lbs
LHLP 3500G		3,500 lbs.	80"		795 lbs
LHLP 2500G		2,500 lbs.			770 lbs

### POWER KITS

OPTION #	OPTION DESCRIPTION
123-NG	Power Kit: 30' "2" Gauge Cable – NO Trailer Plug
136-NG	Power Kit: 35' "2" Gauge Cable – NO Trailer Plug
257-NG-30	Power Kit: 30' "2" Gauge Cable – Dual Pole with Combo Box (Dual/Single Pole Receptacles)
257-NG-45	Power Kit: 45' "2" Gauge Cable – Dual Pole with Combo Box (Dual/Single Pole Receptacles)
257-NG-60	Power Kit: 60' "2" Gauge Cable – Dual Pole with Combo Box (Dual/Single Pole Receptacles)

### CHASSIS WIDTH REQUIREMENTS

MINIMUM	MAXIMUM
L = 26"	L = 45"

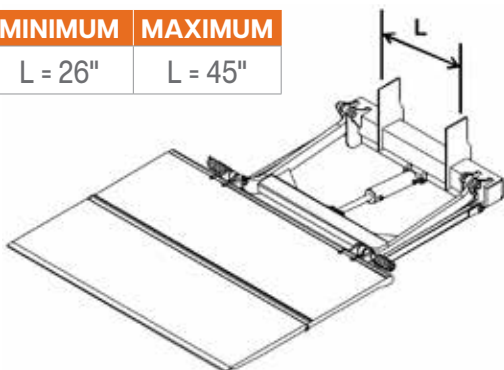

### AVAILABLE OPTIONS

OPTION #	DESCRIPTION
103	Handheld Remote, Plugs Into Receptacle
107	Emergency Hand Pump
111	Additional Circuit Breaker for Supply Line
132-3PL	Plastic Battery Box w/Hold Down Straps (Holds 3 Batteries)
143	Safety Cut Off Switch
145	6" Rubber Dock Bumpers
145-12	12" Rubber Dock Bumpers
188	Trailer Mounting System
194	Threshold Mounting Tube
214	Maintenance Minder2 (LHLP 2500G/3500G)
215	96" Floor Extension
215 BOLT ON	96" Bolt-On Floor Extension
216	102" Floor Extension
216 BOLT ON	102" Bolt-On Floor Extension
219	86" Wide Platform (LHLP 2500G/3500G)
229	I.C.C. Bumper D.O.T. Approved
233	Step with Threshold Tube
233 LHLP	Heavy Duty Steps (Non-Adjustable)
233 ADJ	Heavy Duty Steps (Adjustable)
233ADJ-FLEX	Heavy Duty Wire Rope Steps (Adjustable)
GV	Galvanized Full Gate