

# LEYMAN LIFT GATES®

## Model LHS

LHS 2500  
LLBS 2500

## HIDE-A-WAY®

Standard Duty Tuckunder Style

Wedge  
Platform  
Available!

Power Units have Thermal  
Protection on Motor and  
Marine Grade Toggle Switch!

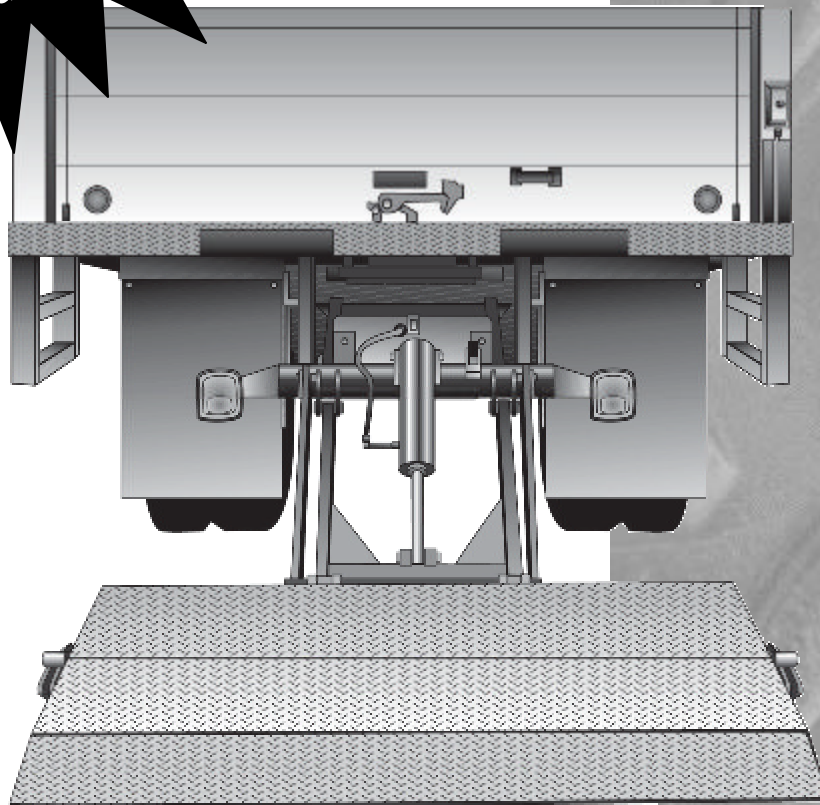

# LEYMAN LIFT GATES®

10900 Kenwood Road • Cincinnati, OH 45242

Phone: 513.891.6210 • Fax: 513.891.4901

[www.leymanlift.com](http://www.leymanlift.com)

[sales@leymanlift.com](mailto:sales@leymanlift.com)

# HIDE-A-WAY®

## Model LHS

### Standard Features

- Greaseless bushings
- Manual transit lock
- Chrome plated pins
- Pressure compensated flow control
- Spring assisted opening and closing
- Low P.S.I. due to larger cylinder surface
- Power pack enclosure for motor and pump
- Marine toggle switch (no linkage)
- Heavy duty platform extension
- Power line 35' "2" gauge

### Optional Features

- Heavy duty steps
- Safety cut off switch
- Circuit breaker for pump motor

### Standard Specifications

#### Model LHS 2500/LHS 2500W

**Capacity:** 2500 lbs.

**Weight:** 750 lbs.  
(approx.)

#### Platform

**Size:** 72" wide x 38" deep + 5" taper  
72" wide x 45" deep (wedge)

#### Floor

**Heights:** 42" - 56"

#### Model LLBS 2500/LLBS 2500W (Low Floor Applications)

**Capacity:** 2500 lbs.

**Weight:** 675 lbs.  
(approx.)

#### Platform

**Size:** 72" wide x 29" deep + 7" taper  
72" wide x 35" deep (wedge)

#### Floor

**Heights:** 36" - 49"

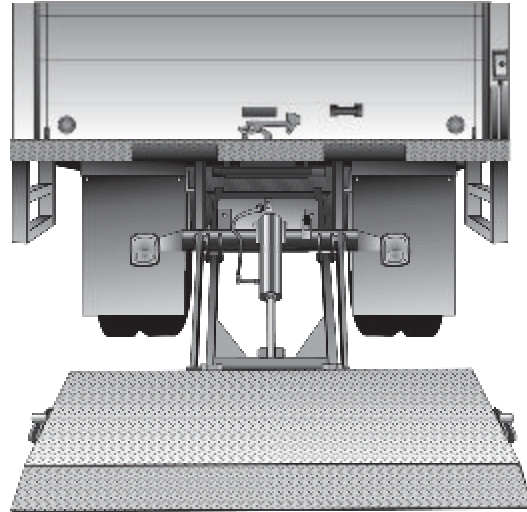

### Lowered Position

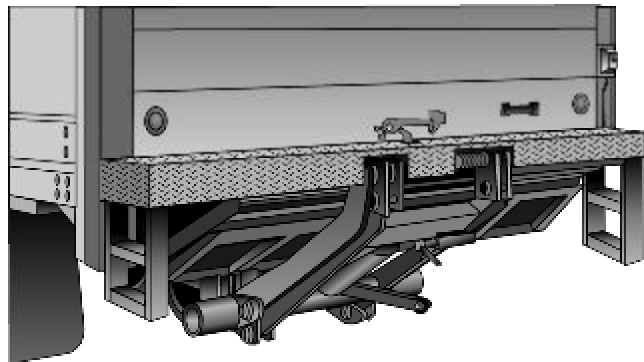

### Over the Road Position

**LEYMAN**  **LIFT GATES®**

10900 Kenwood Road • Cincinnati, OH 45242

Phone: 513.891.6210 • Fax: 513.891.4901

[www.leymanlift.com](http://www.leymanlift.com)

[sales@leymanlift.com](mailto:sales@leymanlift.com)

LML00339-6/9/09