

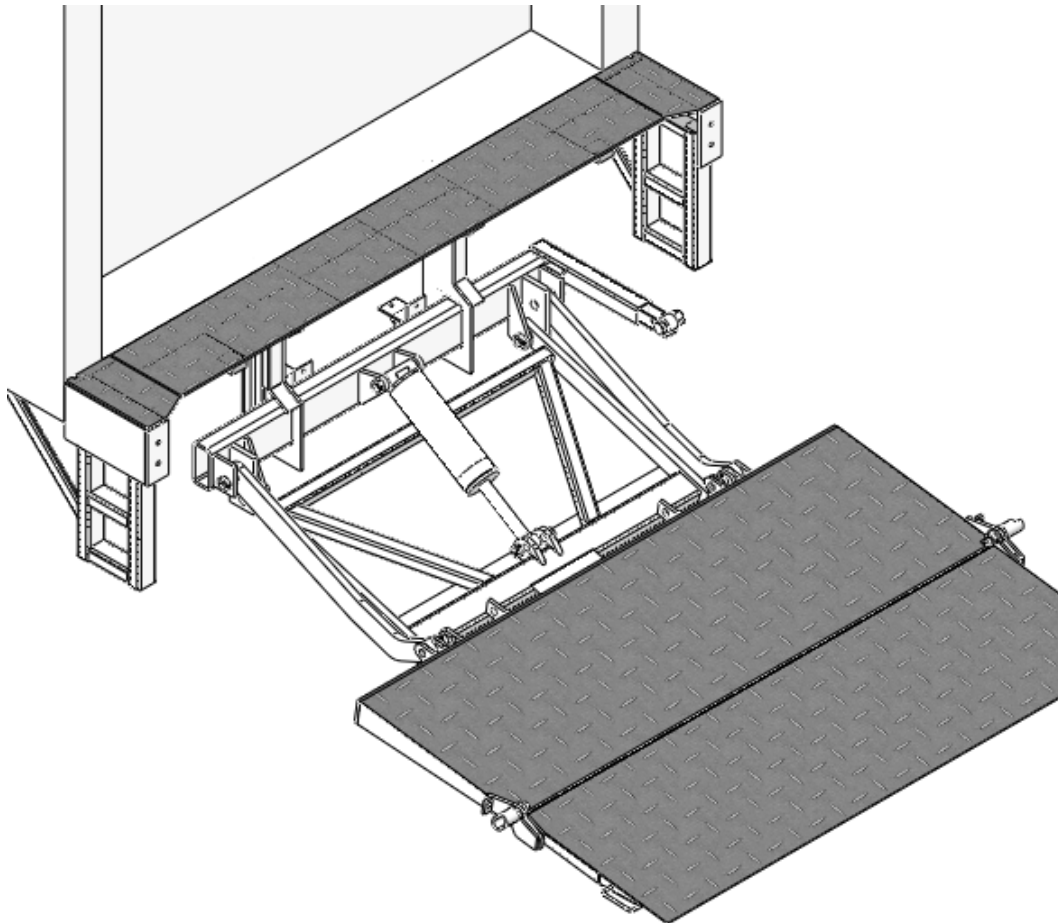

Owner's Manual

SLP Hide-A-Way[®]

Tuckunder Style



10900 Kenwood Road • Cincinnati, OH 45242
Ph: 513-891-6210 • Toll-Free: 866-539-6261
Fax: 513-891-4901
www.leymanlift.com • sales@leymanlift.com

TABLE OF CONTENTS

Introduction	3
Words of Caution	4
Operation of the Lift Gate	5
Preventative Maintenance	6
Troubleshooting Chart	7
Replacement Parts	8-9
SLP Wiring and Power Unit	10-11
Recommended Hydraulic Oils	12
Decal replacement	13

INTRODUCTION

This manual contains the operating procedures on the equipment your company is using that was manufactured by Leyman Manufacturing Corporation.

Past experience has indicated that it is most unwise to operate these units without proper instructions, which should be instituted by the purchaser.

While these products have certain safety features engineered into their design, they are all operated by human beings. Therein lies the problem of safety and one should always have caution in mind when operating this or any other machine that has parts that weigh several hundred pounds.

Again, let us remind you that there are moving parts on this product that weigh several hundred pounds. These parts, when not under proper control, can cause physical damage to the operator. Because of the weights that are involved; carelessness and neglect of training can make these units dangerous.

Do not overload this product. Maintain it properly. Stand clear of moving parts. Operate as instructed.

This lift gate has a long life expectancy and will take some abuse. Use good judgment when operating this equipment.

PLEASE FILL IN FOR YOUR RECORDS

Customer:	_____
Model:	_____
Capacity:	_____
Type:	_____
Power:	12 volt
Platform:	_____
Serial #:	_____
Options:	_____ _____ _____
Maximum Height:	56"
Hydraulic Pressure:	2,500 PSI at the pump, by-passing
AMP Draw:	Loaded 210, Unloaded 100

When placing parts order, you will need the serial # and model # of the lift gate.

WORDS OF CAUTION

1. Before any maintenance is performed on this unit, read and understand this manual completely.
2. Do not stand on or behind the platform when operating gate in the folded position.
3. Make sure the ground is clear under the platform when lowering.
4. Do not stand in front of platform when lowering from vertical position or operating in any manner.
5. Never exceed the rated load capacity of this gate.
6. Do not allow persons to operate the unit unless they have been properly trained to do so.
7. Use only factory authorized parts for replacement.
8. Check the area around the unit for persons before operating the lift gate.
9. This lift gate should operate smoothly and the only noise that should be heard is the power unit. Any audible sounds other than the normal power unit operation sound should be thoroughly inspected and the cause of the noise should be pin-pointed and corrected.
10. Do not over load – the maximum rated capacity is based on an evenly distributed load all over the platforms flat surface.
11. Always load as close to the center of the platform and as close to the center of the truck sill as possible.
12. 150 Amp circuit breaker (not supplied) must be installed between the starter solenoid and the battery source.
Order from factory as option #111-Circuit Breaker.

We urge the installation of a safety cut-off switch for all truck mounted lift gates. These are installed in the cab of the vehicle, so the power to the lift gate can be turned on/off.

WARNING: Pressure relief valve in power unit must NEVER be set above 2500 psi. Pressure above 2500 psi can damage lifting arms. Failure to follow this warning could result in accident or injury.

WARNING: Since this gate has greaseless bearings in the main pivot points, (tension and compression arms and platform parts) any welding on these parts must be grounded or you will damage the cylinder.

OPERATION OF THE LIFT GATE

- Before operating the lift, read and understand this decal, urgent warning decal, and the Owner's Manual.
- Do not stand behind the lift gate while unfolding or using the platform.

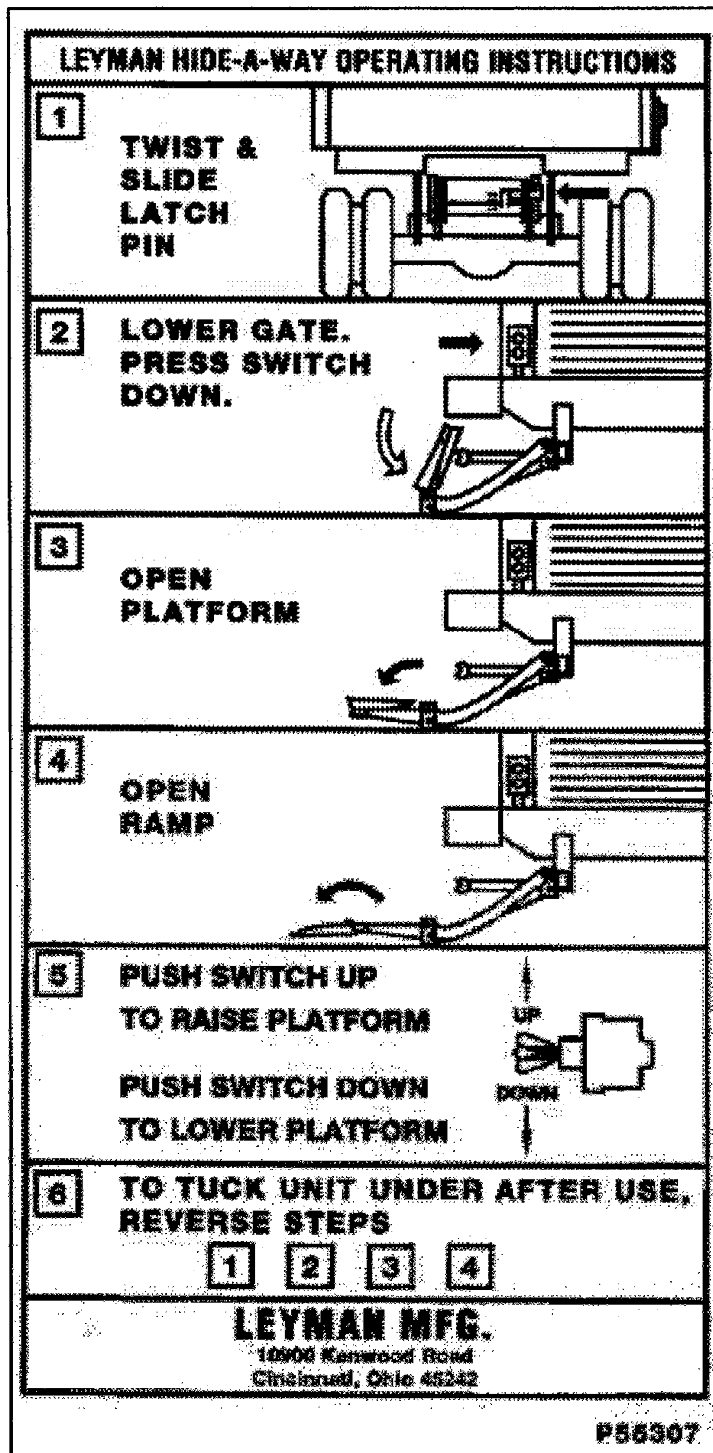



10900 Kenwood Road • Cincinnati, OH 45242
 Ph: 513.891.6210 • Toll-Free: 866.539.6261 • Fax: 513.891.4901

SAFETY AND PREVENTIVE MAINTENANCE INSPECTION
 HIDE-A-WAY™ TUCK-UNDER STYLE GATE MODEL LH/LHR/LLB/SLP/TSG
 Maintenance by Months

CUSTOMER:		
LOCATION:		
VEHICLE#:	LIFT GATE MODEL#:	LIFT GATE SERIAL#:

√ = OK A = ADJUSTED N = NOT APPLICABLE X = WRITE UP REPAIR

3 MO	6 MO	12 MO	MOTOR – PUMP AND COMPONENTS
			Check that battery holds downs are anchored securely
			Check battery(ies) for proper charge level. PROPER CHARGE LEVEL:
			Check all wiring connections for tightness (batteries, switches, etc.)
			Check solenoids for loose fittings and operation.
			Check reservoir for correct amount of fluid (platform should be down when checking)
			Inspect and check all circuit breakers. Replace if necessary.
			Check the charge line/power line for proper operation and connections at both ends.
			Remove and clean all pump solenoid cartridges.
			Replace hydraulic fluid in reservoir (see owners manual for recommended fluids).
			Check and adjust the relief valve setting (2500 psi max.). See Warning on Page. 4.
			Check brushes and armature in motor. Replace if necessary.
			Check amperage draw of motor (see owners manual for recommended amp draw)
3 MO	6 MO	12 MO	LUBRICATION
			Lightly lubricate platform and ramp hinges.
			Lubricate all zerk fittings, if present. Greaseless gates have greaseless bushings.
3 MO	6 MO	12 MO	LIFT GATE STRUCTURE INSPECTION
			Raise and lower lift gate. Observe for correct operation.
			Check hoses and fittings for chaffing, rubbing and leaks.
			Check all pivot pins and bushings for wear. Repair immediately. See Warning below .
			Check operation of transit latch (safety latch). Repair as necessary.
			Check up and down cylinder for leaks. Repack or replace cylinder.
			Inspect for broken and/or missing roll pins.
			Steam clean gate. Repair any structural welds as needed.
			Repaint where needed and replace and worn or missing safety decals.

SERVICED BY: _____ DATE: _____ Form June-07

WARNING: Worn pivot pins or missing bushings must be replaced immediately. Failure to follow this warning could result in accident or injury.

TROUBLE SHOOTING CHART

ALL SLP MODELS

<i>PROBLEM</i>	<i>PROBABLE CAUSE</i>	<i>REMEDY</i>
The motor is running, but the platform will not go up, or reach floor of vehicle or gate will not lift rated load.	<ol style="list-style-type: none"> 1. Insufficient oil in power unit tank. 2. Lowering valve stuck partially or fully open. 3. Power unit relief valve is set too low. 	<ol style="list-style-type: none"> 1. Fill tank. 2. Clean or replace. 3. Turn screw in all the way, then back off one turn.
The platform will not go up or reach floor level and the motor does not run.	<ol style="list-style-type: none"> 1. Battery is low. 2. Power line is loose. 3. Poor switch connections. 4. Cab switch is turned off. 5. Defective starter solenoid. 6. Tripped circuit breaker. 	<ol style="list-style-type: none"> 1. Recharge the batteries. 2. Check the connection, if loose tighten. Also, check for corrosion and clean if necessary. 3. See #2. 4. Turn the switch on. 5. Replace part. 6. Reset the circuit breaker.
Platform will not lower.	<ol style="list-style-type: none"> 1. Battery is low. 2. Bad ground or electrical connection. 3. Lowering valve is bad. 	<ol style="list-style-type: none"> 1. Recharge the batteries. 2. Check for corrosion and tighten. 3. Check the coil.
Platform creeps downward.	<ol style="list-style-type: none"> 1. Defective cylinder or piston seal. 2. Lowering valve is not seating or is partially open. 	<ol style="list-style-type: none"> 1. Remove breather – activate to see if there is a continuous flow of oil. 2. Clean and inspect.
Platform goes down slowly.	<ol style="list-style-type: none"> 1. Lowering valve not fully open or is clogged. 2. Lines are restricted or flow control is clogged. 	<ol style="list-style-type: none"> 1. Clean and replace the lowering valve. 2. Check for bent or pinched lines. Clean or replace the flow control.
Bent latch pin.	<ol style="list-style-type: none"> 1. Latch block welded too far from the latch pin-allows mechanism to bounce. 2. Cylinder piston seal leaking. 	<ol style="list-style-type: none"> 1. Weld block 1/16 away from pin. 2. Remove vent line – activate to see if there is a continuous flow of oil. Replace cylinder.
Hydraulic oil leak from cylinder rod end.	<ol style="list-style-type: none"> 1. Gland nut too loose. 2. Cylinder rod pitted. 	<ol style="list-style-type: none"> 1. Turn gland nut 1/2 turn – do not over tighten. Some cylinders do not have gland nuts. 2. Replace cylinder.

REPLACEMENT PARTS

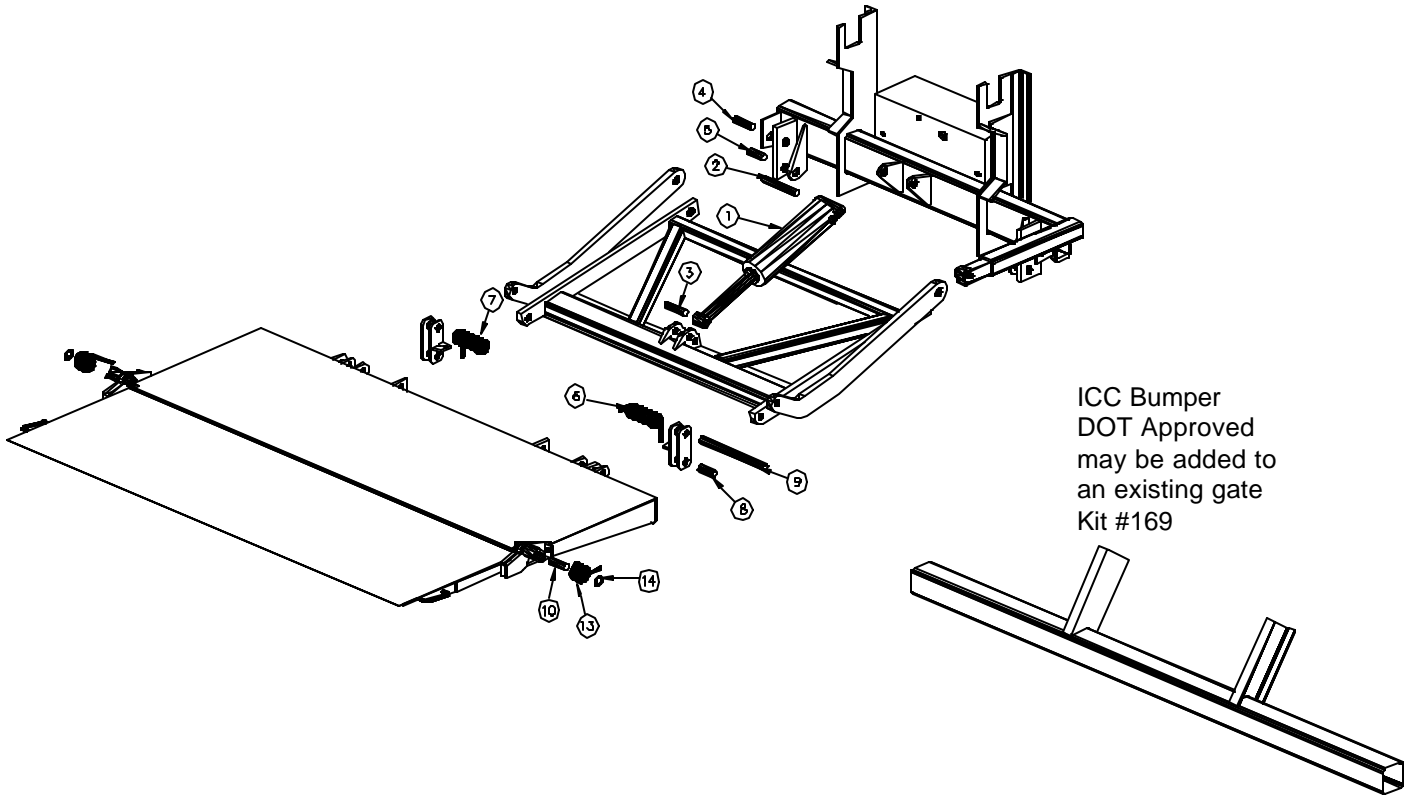

Item #	Part #	Qty	Description
1	P33989	1	Cylinder 2500 / 3000 gate
1	P33990	1	Cylinder 3500 gate
	P43578	3	Cylinder bushing (for all cylinders)
2	AP-800-227	1	Shaft assembly for cylinder base end
3	AP-800-233	1	Shaft assembly for cylinder rod end
4	AP-800-229	2	Shaft assembly for tension arms
5	AP-800-231	2	Shaft assembly for comp. arm assembly
6	P25179	1	Spring RH (1850 has RH spring only)
7	P25178	1	Spring LH
8	AP-800-235	2	Cam plate pin
9	AP-800-237	2	Platform cam pin
10	AP-800-486	2	Ramp pin
11	P43575	4	Greaseless bearings (1" ID)
12	P43576	4	Greaseless bearings (1-1/4" ID)
13	P25219	2	Ramp Spring
14	P26020	2	Washer
	P47531	12	Roll Pin ¼ x 1-3/4
	P47532	2	Roll Pin ¼ x 2-1/4

CYLINDER SEAL KITS

Gate	Part #	Part Name and Description
2500 / 3000	P33875	Complete seal kit
3500	P33876	Complete seal kit

COMPONENTS NOT SOLD SEPARATELY

COMPLETE SEAL KIT CONSISTS OF:

1. Wiper
2. Packing Gland Nut
3. "V" Packing Kit
4. Piston Seal

Some cylinders do not have gland nuts and "V" packing for rod seal.

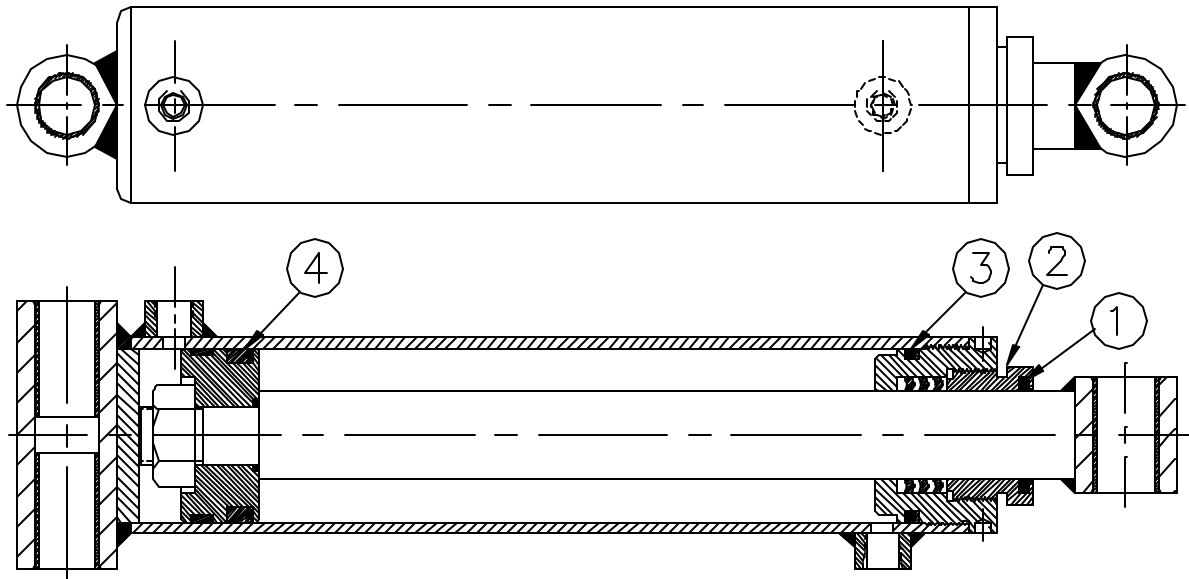

MONARCH POWER UNIT (Gold/Silver Motor with Thermal Switch Protection)

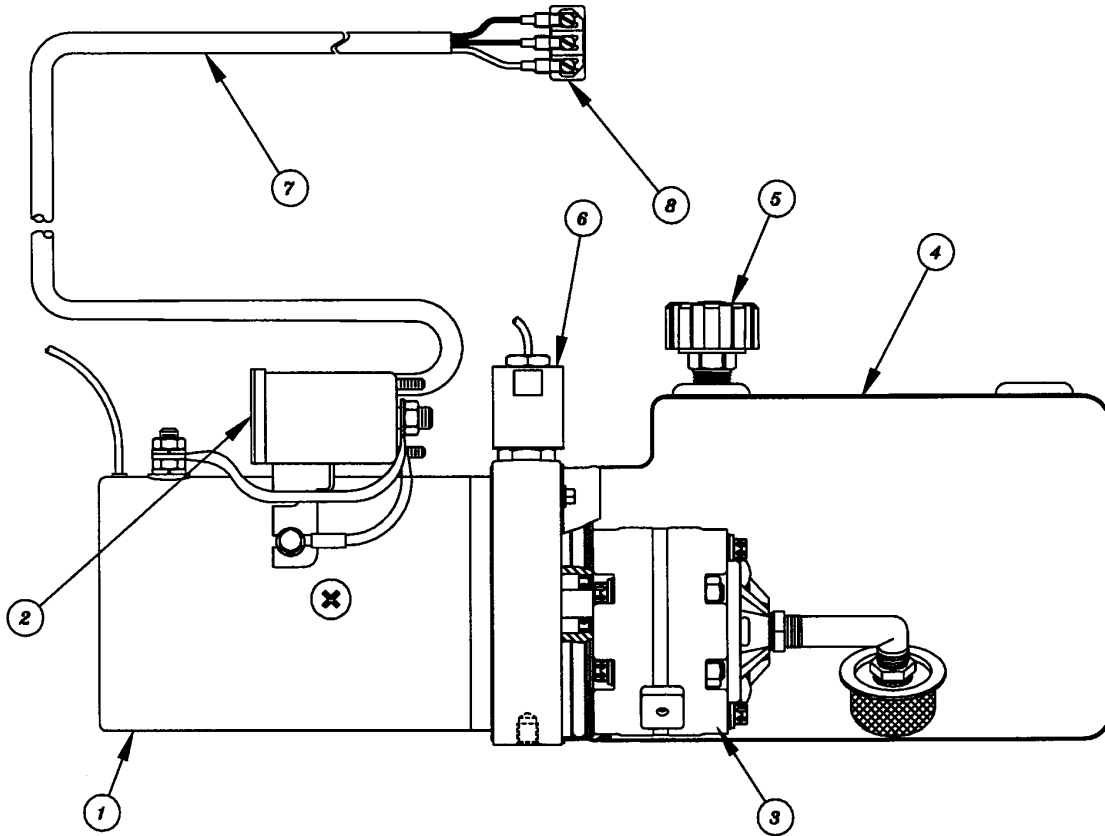

Item #	Part #	Description
	AA-501-407	Power unit (complete)
1	P33992A	Motor
2	P34016	Starter solenoid
3	LH150003	Pump
4	P34018	Tank
5	LH150015	Breather cap
6	LH121	Drain valve
7	P46600	Wire harness w/switch
8	AA-551-547	Potted Switch

SLP WIRING

SLP Gates with Monarch (Gold/Silver Motor) Power Unit – Thermal Switch in Motor (P33991)

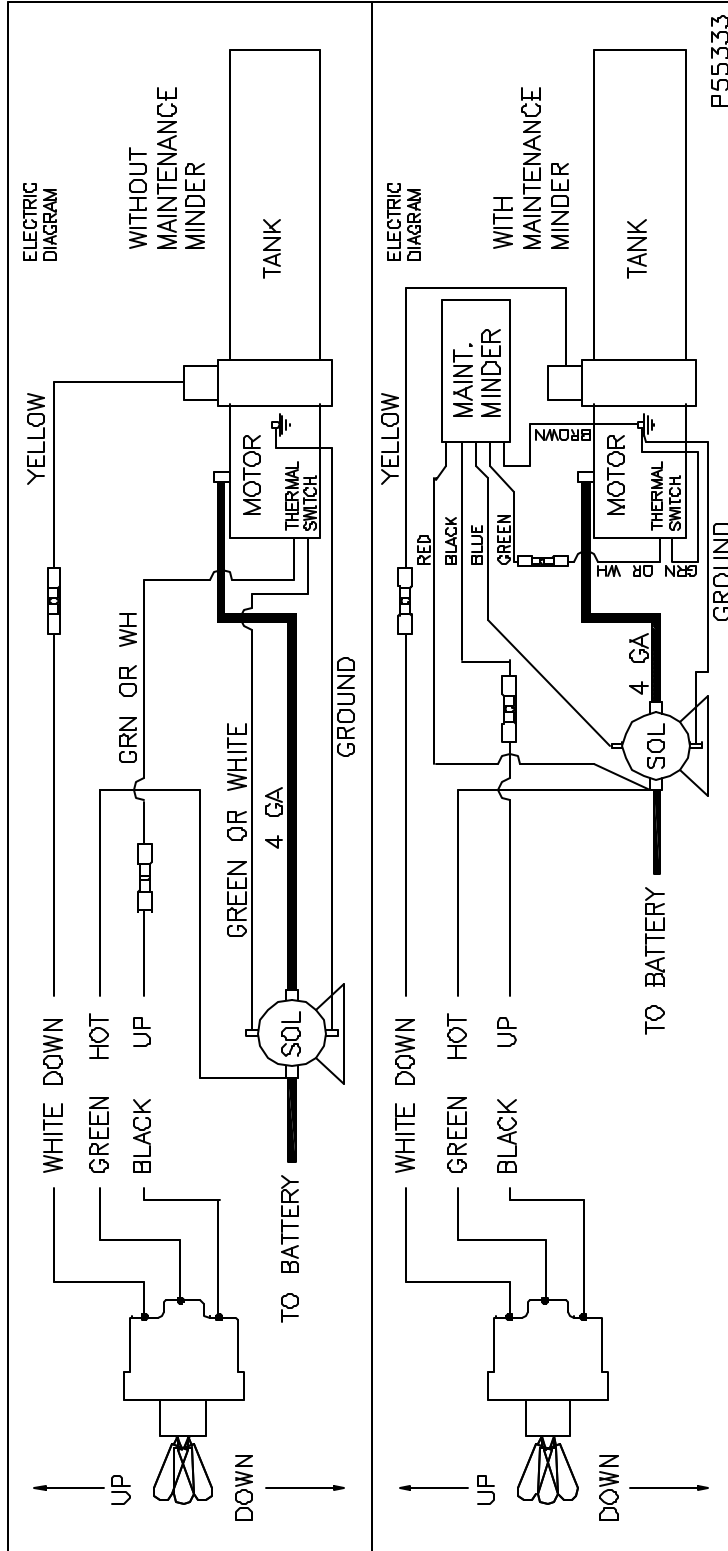

RECOMMENDED HYDRAULIC OILS

Level 1

Normal Conditions

<u>Manufacturer</u>	<u>Type</u>	<u>Temperature Range</u>
Chevron	RYKON ISO-15	-15°F to + 150°F
Mobil	DTE-11	-15°F to + 150°F
Shell	TELLUS-T15	-15°F to + 150°F

Level 2

Cold Conditions

<u>Manufacturer</u>	<u>Type</u>	<u>Temperature Range</u>
Chevron	AVIATION-A	-50°F to + 80°F
Mobil	AERO-HFA	-50°F to + 80°F
Shell	AERO FLUID #4	-50°F to + 80°F
Mil	H-5606	-50°F to + 80°F

DECAL REPLACEMENT

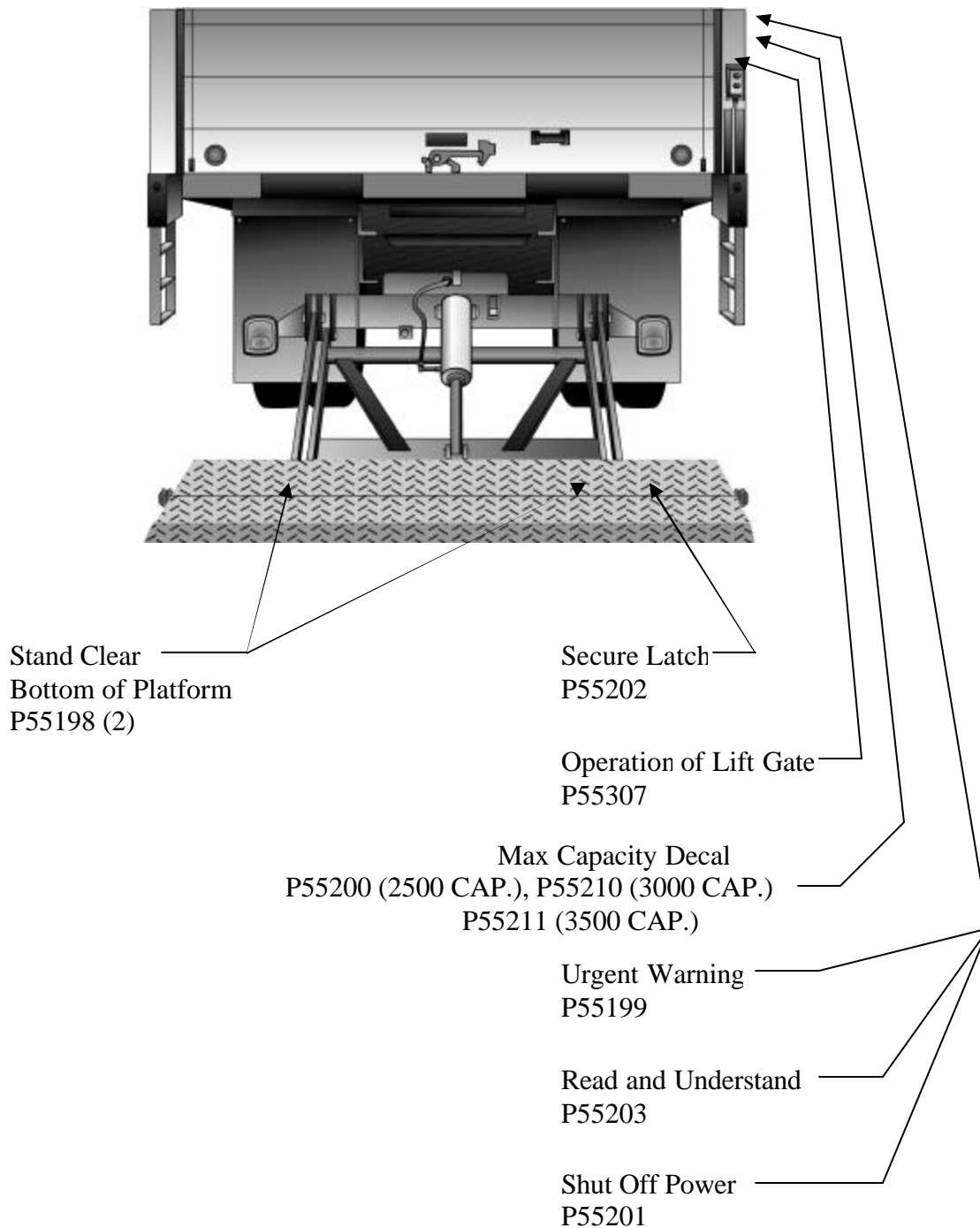

LEYMAN WILL REPLACE ANY DECAL AT NO CHARGE