

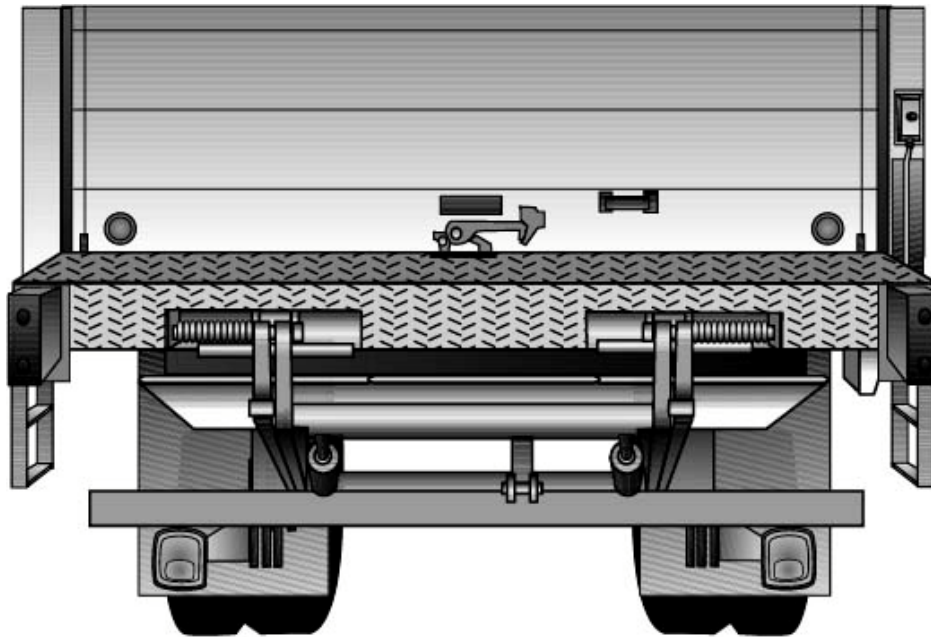

Owner's Manual

LHLP-4500 Hide-A-Way™

Tuckunder Style



LEYMAN MANUFACTURING CORPORATION

10900 Kenwood Road
Cincinnati, OH 45242

1-866-LEYMAN-1 · 1-866-539-6261 · 513-891-6210

Fax 513-891-4761

www.leymanlift.com

sales@leymanlift.com

LML00146-6/7/07

TABLE OF CONTENTS

Introduction	2
Words of Caution	3
Operation of the Lift Gate	
LHLP4500 Operation	4
Hand Pump Operation	5
Maintaining the Lift Gate	
Recommended Oils and Lubrication	6
Preventative Maintenance Schedule	7
Trouble Shooting	
Trouble Shooting Chart	8
Electric Diagram – Hydraulic Diagram	9
Walk Around Push Button Option	10
Emergency Hand Pump Option	11
Battery Hook Up	12
Grounding Recommendations	13
Maintenance Minder2™ Overview	14
Maintenance Minder2™ Controller Menus	15
Parts Replacement	
Power Unit Parts	17
Motor Replacement	18
Hydraulic Assembly	19
Pivot Pins, Bushings, Springs	20-21
Installation Safety Decals	22
Notes	23

INTRODUCTION

This manual contains the operating procedures on the equipment your company is using that was manufactured by Leyman Manufacturing Corporation.

Past experience has indicated that it is most unwise to operate these units without proper instructions which should be instituted by the purchaser.

While these products have certain safety features engineered into their design, they are all operated by human beings. Therein lies the problem of safety and one should always have caution in mind when operating this or any other machine that has parts that weight several hundred pounds.

Again, let us remind you that there are moving parts on this product that weight several hundred pounds. These parts, when not under proper control can cause physical damage to the operator. Because of the weights that are involved: carelessness and neglect of training can make these units dangerous.

Do not overload this product. Maintain it properly. Stand clear of moving parts. Operate as instructed.

This lift gate has a long life expectancy and will take some abuse. Use good judgment when operating this equipment.

PLEASE FILL IN FOR YOUR RECORDS

Customer:	
Model:	LHLP4500-8663CS
Capacity:	4500 lbs.
Type:	Hide-A-Way
Power:	12 volts
Platform:	Two piece
Serial #:	
Options:	 <hr/> <hr/> <hr/>
Maximum Height:	60 in
Hydraulic Pressure:	2,500 psi MAX. LIFT 500 psi MAX. POWER DOWN

WHEN PLACING PARTS ORDER, YOU WILL NEED THE SERIAL NUMBER AND MODEL OF THE LIFT GATE.

WORDS OF CAUTION

1. Before any maintenance is performed on this unit, read and understand this manual completely.
2. Do not stand in front or behind the platform when lowering from the stored position or when operating the gate in folded position.
3. Make sure the ground is clear under the platform when lowering, check the area around the gate for any persons before operating the gate.
4. This lift gate should operate smoothly and the only noise that you should be heard is the power unit. Any audible sounds other than normal power unit operation sound should be thoroughly inspected and the cause of noise should be pinpointed and corrected.
5. Never exceed the rated load capacity of this gate.
6. Always load as close to the center of the platform and close to the truck or trailer sill.
7. Do not allow persons to operate the unit unless they have been properly trained to do so.
8. Inspect the hydraulic cylinders seals for leakage every six (6) months.
9. Inspect hydraulic lines for cracks or deterioration every six (6) months.
10. Check the level of the hydraulic oil in the power unit tank once a month.
11. Clean the hydraulic power unit strainer and in-line filter every three (3) months.
12. Always disconnect the battery from the power source before servicing the unit.
13. Use only factory authorized parts for replacement.

WARNING: SINCE THIS GATE HAS POLYMER GREASELESS BEARINGS IN THE MAIN PIVOT POINTS, (TENSION ARM, COMPRESSION ARM AND CYLINDER PIVOTS) ATTACH GROUND WIRE CLOSE TO WHERE YOU ARE WELDING OR YOU WILL DAMAGE CYLINDER AND OTHER COMPONENTS.

LHLP 4500 OPERATING INSTRUCTIONS

- Before operating the lift gate, read and understand this decal, urgent warning decal and the Owner manual.
- Do not stand behind the lift gate while unfolding or using the platform.

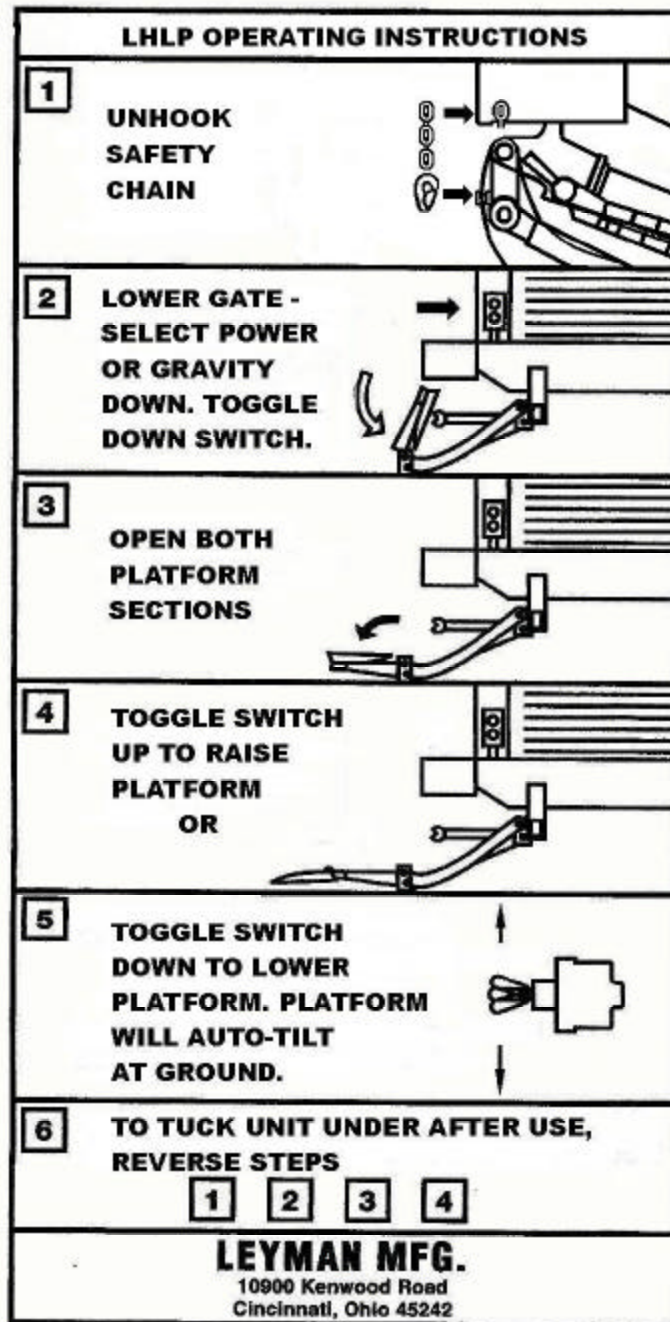

P55329

OPERATING THE HAND PUMP (OPTIONAL)

1. Inside the power unit enclosure, turn the ball valve (plastic covered handle) 90° to the full open position. The handle will be inline with the valve body and hose when fully open.
2. Using the handle, slowly turn the valve located on the hand pump to let the lifting gear down. Fold platform closed. Close valve at pump base.
3. Insert the handle into the pump and pump to raise lifting gear.
4. Latch over-the-road safety chain. Close ball valve in power unit.

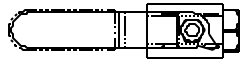

BALL VALVE CLOSED
(HANDLE IN-LINE WITH BODY)

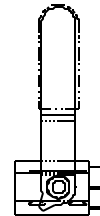

BALL VALVE OPEN
(HANDLE PERPENDICULAR TO BODY)

RECOMMENDED OILS AND LUBRICATION

HYDRAULIC OILS	MANUFACTURER	TYPE	TEMP. RANGE
Level 1 Normal Conditions	Mobile	DTE 11	-15° F to + 150° F
	Shell	TELLUS-T15	-15° F to + 150° F
	Exxon	UNIVIS N15	-15° F to + 150° F
	Chevron	RYKON ISO-15	-15° F to + 150° F
Level 2 Cold Conditions	Mobile	AERO-HFA	-50° F to + 80° F
	Shell	AERO FLUID#4	-50° F to + 80° F
	Exxon	UNIVIS HVI 13	-50° F to + 80° F
	Chevron	AVIATION-A	-50° F to + 80° F
	Mil	H-5606	-50° F to + 80° F

HYDRAULIC TANK CAPACITY
3.8 quarts

LUBRICATION	
Grease	Multi Purpose #35

BATTERIES
Two (2) 12 V D.C. Group 31 Deep Cycles

ELECTRICAL COMPONENTS CONNECTIONS
Use Battery terminal protection Bowman Part#21948

AMPERAGE DRAW OF MOTOR
When raising platform (empty) approximately 120 AMP @ 12 volts. At bypass approximately 180 AMP @ 12 volts

LIFTING PRESURE SETTING
With platform at floor level and pump in bypass 2500 psi

MINIMUM VEHICLE FLOOR HEIGHT LADEN
47" vehicle floor height

MAXIMUM VEHICLE FLOOR HEIGHT UNLADEN
60" vehicle floor height

APPROXIMATE TIME EMPTY AT 80° F WITH 2 153 AMP HOUR BATTERIES
Time up: 17 – 19 seconds Time down: 17-19 seconds (power down)

PREVENTATIVE MAINTENANCE SCHEDULE

MAINTENANCE by CYCLES

MODELS LHL P4500 AND LHL P5500

CUSTOMER:			
LOCATION:			
VEHICLE #:	GATE MODEL #:	GATE SERIAL #:	

v = OK A = ADJUSTED N = NOT APLICABLE X = REPAIR

2000 CYCLES	MOTOR / PUMP COMPONENTS		
	Check batteries for corroded, loose, or broken connections		
	Check batteries for proper voltage level and charging		
	Check all wiring in pump box for corroded, loose, or broken connections		
	Check pop-it solenoids for proper operation		
	Check reservoir for proper oil level (Gate down on the ground and tilted 1" from top of tank)		
	Inspect circuit breakers and fuses for proper operation		
	Check charge line / power line for corroded, loose or broken connections at both ends		
	Check amp draw of motor with batteries fully charged batteries and tight clean connections		
	Check all ground wires for corroded, loose, or broken connections		
	Check pressure setting of relief valve		
	Clean and all wiring connections in pump and battery box and spray with Bowman # 21948 connection protection or equivalent		
	STRUCTURE COMPONENTS		
	Check for proper operation of gate up/ (power and gravity) down, fold/unfold		
	Check platform and lifting gear for any impact damage		
	Check cylinders and hydraulics line for leaks, abrasions, cuts, or broken lines and fittings		
	Check all cylinder pins for loose, broken, or missing roll pins		
	Check all pivot pins for loose, broken, or missing roll pins and snap rings		
	Adjust platform level at adjusting screws on compression arms at platform as needed		
	Adjust alignment bolts as needed between primary and secondary platforms		
	Steam / pressure wash all components as needed		
	Check proper operation of cart stops		
	LUBRICATION		
	Gates used infrequently may need penetrating oil at pivot bushings		
	Grease power unit and battery box door hinges		
12000 CYCLES	PERIOICAL CHECK LIST		
	Check pivot point bushings for wear or damage		
16000 CYCLES			
	Flush hydraulic system and change hydraulic oil		
	Clean and repaint as necessary		
MAINTENANCE MINDER ² READINGS MENU 2			
Screen 1 # Lifts	Screen 3 Service Faults	Screen 4 Low Voltage Faults	Screen 6 High Temperature Faults

Check owner's manual for proper hydraulic oil, motor amp draw, and pressure setting of power unit

Service By: _____

Date: _____

TROUBLE SHOOTING CHART LHLP-4500

PROBLEM	POSIBLE CAUSE	SOLUTION
The platform will not go up or reach floor level.	<ol style="list-style-type: none"> 1. Battery is low 2. Slave line is disconnected or connections are loose (battery and motor). 3. Insufficient oil in power unit tank 4. Poor switch connections 	<ol style="list-style-type: none"> 1. Recharge battery 2. Connect the slave line property. 3. Fill the power unit tank 4. Clean and check switch connections.
Platform will not lower	<ol style="list-style-type: none"> 1. Battery is low 2. Poor switch connections 3. Check lowering valve (2 way). 	<ol style="list-style-type: none"> 1. Recharge battery 2. Clean and check switch connections. 3. Clean/replace as necessary.
Platform creeps down	<ol style="list-style-type: none"> 1. Dirt under the ball of the check valve, the ball is pitted, worn or the spring is weak. 2. Hydraulic leak. 3. Cylinder piston seals failing. 	<ol style="list-style-type: none"> 1. Clean 2. Check all hoses and fittings. 3. Replace cylinder seals.
Platform goes down slowly	<ol style="list-style-type: none"> 1. Excessive wear of mechanical components. 2. Restriction in hydraulic system. 3. Incorrect hydraulic oil in system for cold weather. 	<ol style="list-style-type: none"> 1. Insure free movement of all mechanical parts. 2. Check strainers on valve stems. 3. Use Mobile Aero-HFA in cold weather.
Platform comes down crooked	<ol style="list-style-type: none"> 1. Flow control valve problem. 2. Air in system. 	<ol style="list-style-type: none"> 1. Replace flow control/valves in pairs. 2. Bleed cylinder.
Gate will not lift the rated load.	<ol style="list-style-type: none"> 1. Hydraulic pump is worn. 2. Battery is too low. 	<ol style="list-style-type: none"> 1. Change the pump. 2. Recharged the battery to full charge.
Pump will not operate	<ol style="list-style-type: none"> 1. Battery too low. 2. Electrical hookup to motor not making contact. 3. Control switches are not making good contact. 4. Maintenance Minder2 controller has shut down the system due to the low voltage. Must maintain 8 volts minimum under load. 	<ol style="list-style-type: none"> 1. Recharge the battery and check to be sure that slave line has a good connection. 2. Clean connection and re-tighten. 3. Clean and check the connections. 4. Use the "Last Lift Menu" data on screen to read maximum and minimum voltages, recharge battery.

ELECTRICAL & HYDRAULIC DIAGRAM

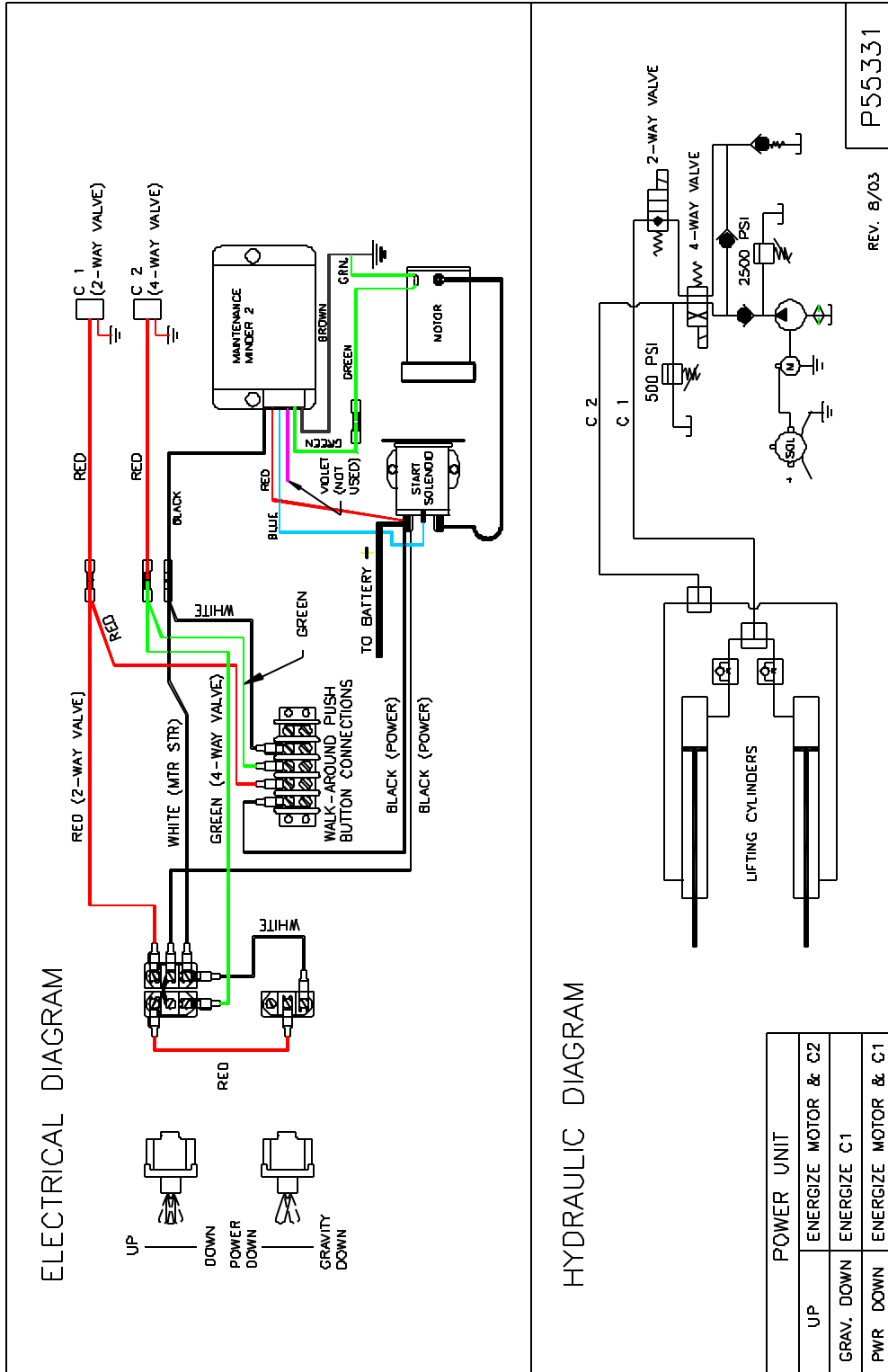

WALK AROUND PUSH BUTTON OPTION

CHANGES	
A	ADDED R/W 5/1/06
B	ADDED R/W 4/13/07

INSTALLATION INSTRUCTIONS:

- 1) SELECT A LOCATION FOR MOUNTING THE 4 WAY FEMALE PLUG AND WELD THE MOUNTING PLATE IN PLACE.
- 2) CONNECT THE 16-4 CABLE WIRES TO THE FEMALE PLUG AS SHOWN IN THE DIAGRAM. ADD DIELECTRIC GREASE TO CONNECTIONS, THEN INSTALL HEAT SHRINK TO SEAL CABLE AND FEMALE SOCKET.
- 3) MOUNT PLUG AND RUN CABLE TO POWER UNIT. SUPPORT CABLE USING LOOM CLAMPS AND SCREWS.
- 4) ASSEMBLE CORD GRIP IN POWER UNIT BOX HOLE. INSERT CABLE THRU CORD GRIP AND CUT TO REQUIRED LENGTH. INSTALL FORK TERMINALS WITH HEAT SHRINK SEALS. CONNECT TO TERMINAL STRIP BY MATCHING WIRE COLORS.
- 5) SELECT A LOCATION FOR PUSH BUTTON HOOK ASSEMBLY AND MOUNT.

14	1	AA-999-180	P B HOOK ASSY.			NOT SHOWN
13	1	P48856	HEAT SHRINK 1.1" DIA.		1 PC - 3 IN.	
12	1	P48567	DIELECTRIC GREASE PACKET			NOT SHOWN
11	5	P17518	SELF TAPPING SCREW			NOT SHOWN
10	5	P48250	LOOM CLAMP			NOT SHOWN
9	1	P48139	CORD GRIP			NOT SHOWN
8	4	P48476	LOCKING FORK TERMINAL			NOT SHOWN
7	1	BA-551-352	WAPB ASSEMBLY			NOT SHOWN
6	1	P48314	JACKETED WIRE	16-4	120" LONG	
5	2	P23502	LOCK NUT		1/4	
4	2	F28007	FLAT WASHER		1/4	
3	2	P10517	BOLT		1/4-20 X 5/8	
2	1	P48329	4 WAY PLUS CONN. FEMALE			
1	1	AP-551-236	MTC PLATE			

TOLERANCE		LEVMAN MANUFACTURING CORPORATION	
FRACIONS : 1/64	DECIMALS : 0.0005	DATE : 1/2/03	MODEL : LH1550D
...	...		ASSY : WAPB OPTION
...	...		BA-551-353
...	...		SCALE : 1/4
...	...		TOTAL WEIGHT
...	...		SH. OF

VIEWED FROM BACK

EMERGENCY HAND PUMP OPTION

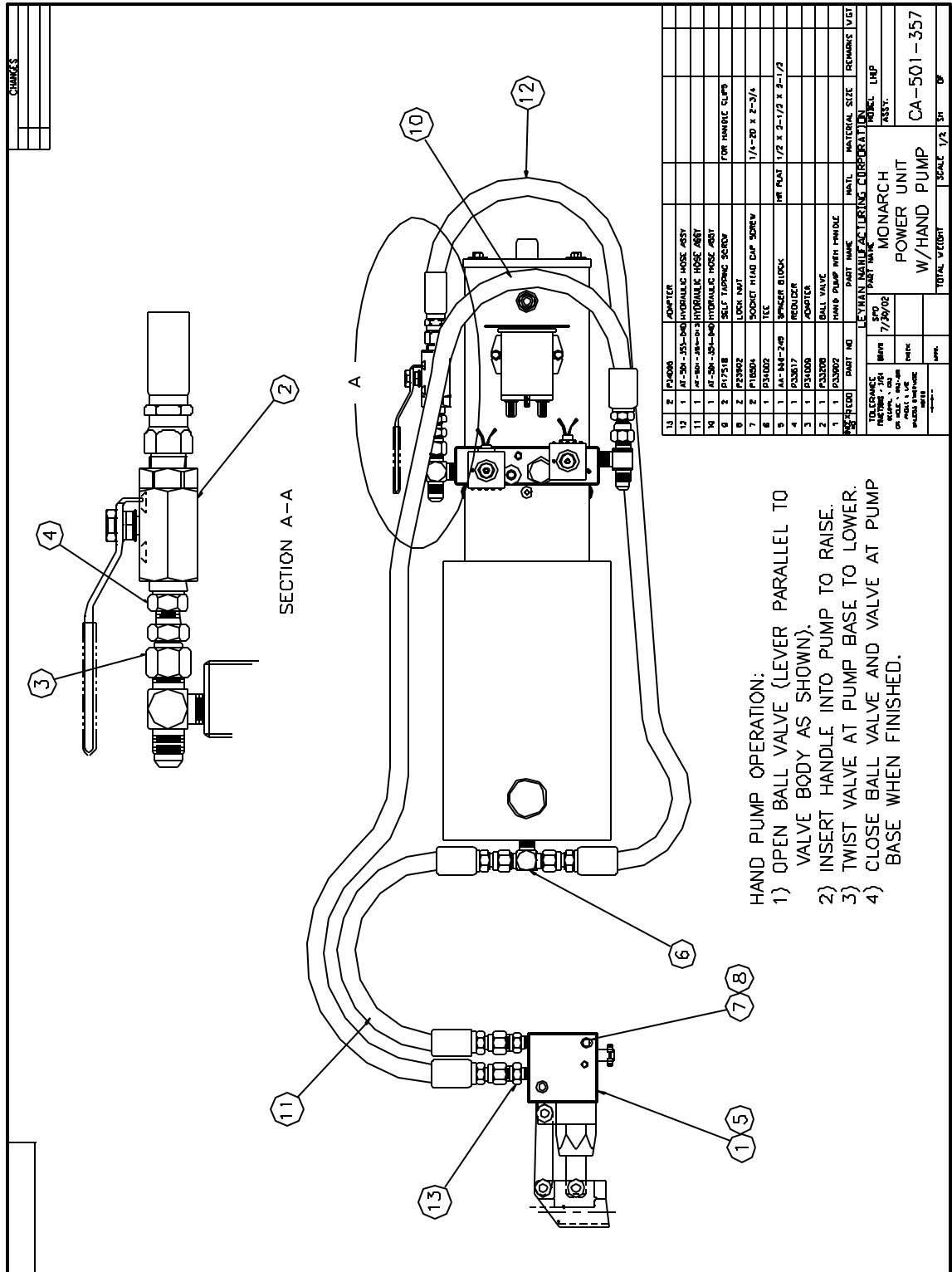

BATTERY HOOK UP

WE RECOMMEND BATTERIES WITH THE FOLLOWING SPECIFICATION:

- 12 Volt Deep Cycle
- B.C.I. Group - Size 31
- Terminal Type - TS
- Cold Cranking Amp -580

ONE CIRCUIT BREAKER
WIRING DIAGRAM

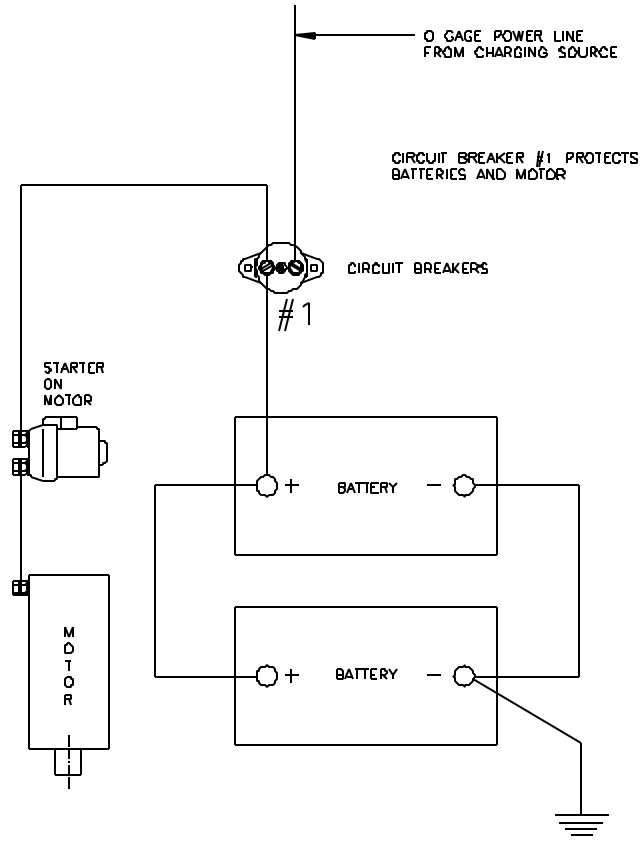

**FAILURE TO USE CORRECT BATTERIES WILL VOID
WARRANTY**

GROUNDING RECOMMENDATIONS

FOR TRACTOR & TRAILER

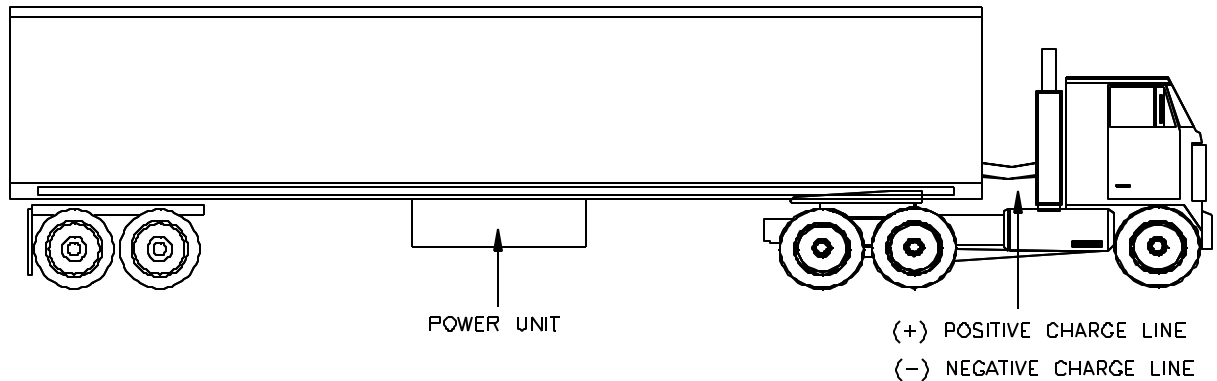

Utilization of a single positive cable does not provide sufficient ground. Therefore, our recommendations for grounding trailers with a LHLP™ gate are as follow:

Two (2) cables: one (1) positive and one (1) negative, both running to the tractor batteries.

The Maintenance Minder 2 controller (optional) requires that a minimum of 8 volts be maintained under load in order for the LHLP 4401 to operate.

NOTE:

The use of a battery charger as the sole power source to operate the LHLP™ is **unauthorized** and will prevent the LHLP™ from working properly. The lift gate must always be operated in conjunction with a least one (1) 12 volt heavy duty lift gate battery. The LHLP Power Unit must be properly grounded. A 5/16" Ground Screw is provide on the pump block to connect a ground wire to the vehicle frame.

MAINTENANCE MINDER 2 CONTROLLER MENUS

Power unit is equipped with the Maintenance Minder 2 Controller. It will:

- Automatically keep track of maintenance intervals and warn the user when maintenance is due, based on the number of lifts.
- Record low voltage occurrences.
- Record of high temperature faults.
- Record of maximum run time faults, when a single operation exceeded the maximum continuous run time limit.
- Give helpful trouble-shooting information on MENU 4, "Last Lift Info".

FAULTS CODES

A decal in the power unit enclosure lists the following signal codes for these faults:

1 BEEP	Service Fault (reached the number of lifts when maintenance is due)
2 BEEPS	Low Voltage Fault (check battery condition and power line connections)
3 BEEPS	Max. Time Fault (exceeded the maximum continuous run time allowed)
4 BEEPS	High Temperature Fault (unit will not run until motor cools)

All fault signals will be repeated FOUR times. Controller will prevent power unit from operating during the time period when a fault signal is sounding (about 5 to 10 sec.) The controller is also equipped with an anti-doorbelling feature, which prevents rapid ON/OFF operation of the power unit.

RESETTING after MAINTENANCE IS PERFORMED

To RESET the Maintenance Minder 2 after maintenance has been performed:

1. Go to MENU 2, hit "ENTER", and toggle down to the "Reset All Info" screen.
2. Press and hold the hidden RESET button under Maintenance Minder 2 logo at top of faceplate.
3. Follow the instructions on the screen regarding a second button, which must be pressed to complete the reset operation.



MAINTENANCE MINDER 2 CONTROLLER MENUS

(Press MENU)

MENU 1 – LIFT GATE INFO

(Press ENTER, then ARROW DOWN for each item)

Model Number, Serial Number, Manufacture Date, Vehicle ID, Hardware Version, Firmware Version, Software Version.



(Press MENU and ARROW DOWN once)

MENU 2 – PERIOD INFO (data for current maintenance period)

(Press ENTER, then ARROW DOWN for each item)

Number of Lifts (gives the number during this maintenance interval and the set number when maintenance is due)

Motor ON (total motor run time in minutes for this maintenance period)

Service Fault (number of times gate was operated while PAST the maintenance limit)

Low Voltage Faults (times low voltage occurred)

Max. Time Faults (times motor exceeded its maximum allowable continuous run time)

High Temperature Faults (times thermal switch in motor tripped, if switch provided)

High Pressure Faults (not being used, no sensor available)

Reset all Info (Reset data after performing maintenance, once maintenance limit is reached – follow instructions for Resetting after Maintenance is PERFORMED.)



MAINTENANCE MINDER 2 CONTROLLER MENUS

(Press **MENU** and **ARROW DOWN** twice)
MENU 3 – LIFT GATE INFO (data for the total life time of the gate)
(Press **ENTER**, then **ARROW DOWN** for each item)

Same items will appear, as under PERIOD INFO, except this is LIFE TIME data.

Reset History (reviews history for each maintenance interval)

Press **ENTER**, then **ARROW DOWN** to show history. Most recent period is highest#. Screen shows Period #, # of Lifts, and Total Run Time in minutes.



(Press **MENU** and **ARROW DOWN** three times)

MENU 4 – LAST LIFT INFO (Trouble Shooting Screen – it records data that occurred during the last lift made)

(Press **ENTER**, then **ARROW DOWN** for each item)

Supply Voltage (first voltage is the minimum voltage that occurred during the last lift – if below 6 volts gate will stop / second voltage is the supply voltage just before gate operation, must be at least 10 volts).

Motor ON (motor run time in seconds during last lift, gate will stop at 180 seconds).

Window Time (time in milliseconds during the last lift that the voltage dropped in between 6 and 8 volts – must not be any longer than 3 seconds or gate will stop).



NOTE:

Controller has an anti-doorbelling feature. Motor will not operate if UP switch is toggled rapidly. This prevents welding of the start solenoid contacts.

POWER UNIT PARTS

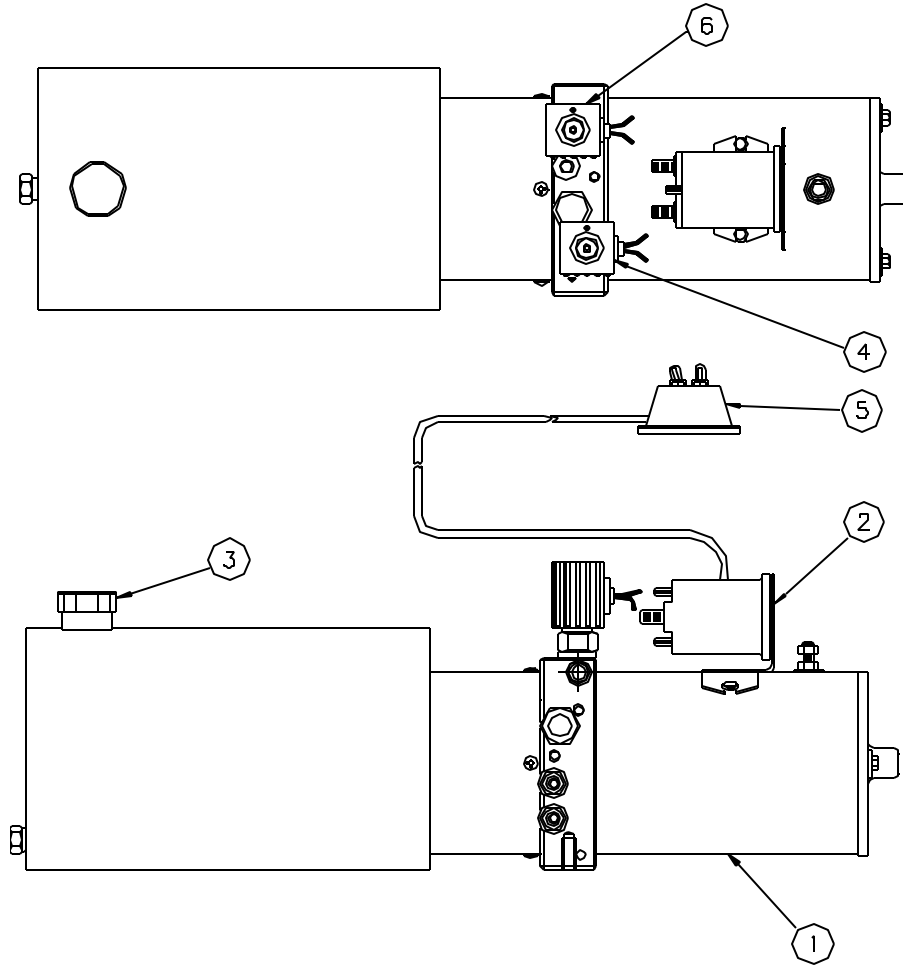

ITEM NO.	PART NO.	DESCRIPTION
	P34000	Power Unit Complete – before 1/1/2004
	P34000A	Power Unit Complete – from 1/1/2004 – 6/1/2007
	P34000B	Power Unit Complete – after 6/1/2007
1	P34027	Motor – before 6 /1/2007
1	P34027A	Motor – after 6/1/2007
2	P34016	Start Solenoid
3	LH150015	Breather Cap
4	P34025	C1, 2 Way, 2 Pos. Solenoid Valve
5	P34001	Wire Harness w/ Switch
6	P34026	C2, 4 Way, 2 Pos. Solenoid Valve

MOTOR REPLACEMENT

P34027A MOTOR
AFTER 6/1/2007 GOLD
WITH SILVER END CAP

P34027 MOTOR
BEFORE 6/1/2007
BLACK OR SILVER

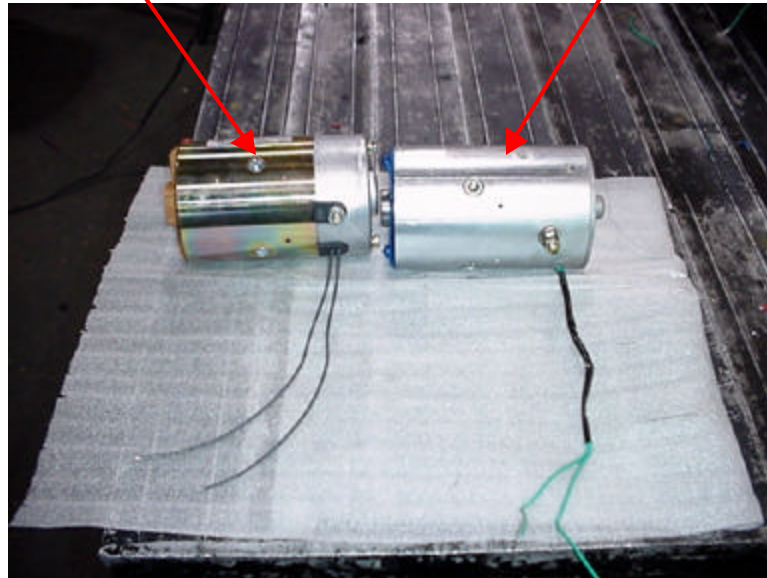

TEMP. SWITCH

P34130 TEMP. SWITCH
WITH BRUSH KIT AFTER
6/1/2007

P34054 TEMP. SWITCH
BEFORE 6/1/2007

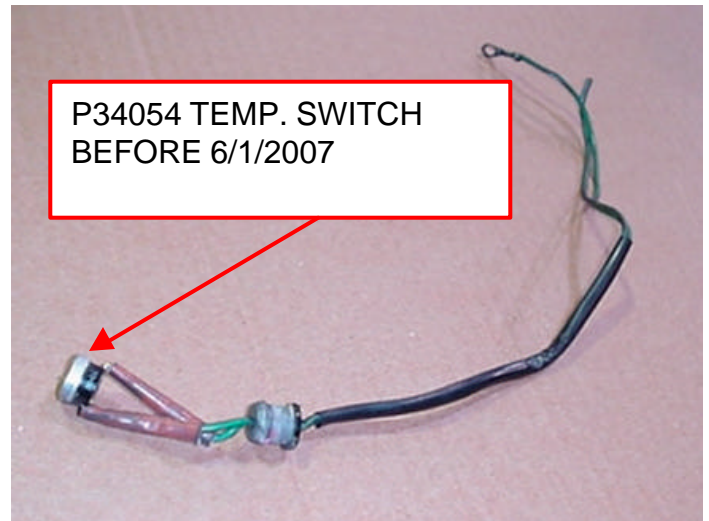
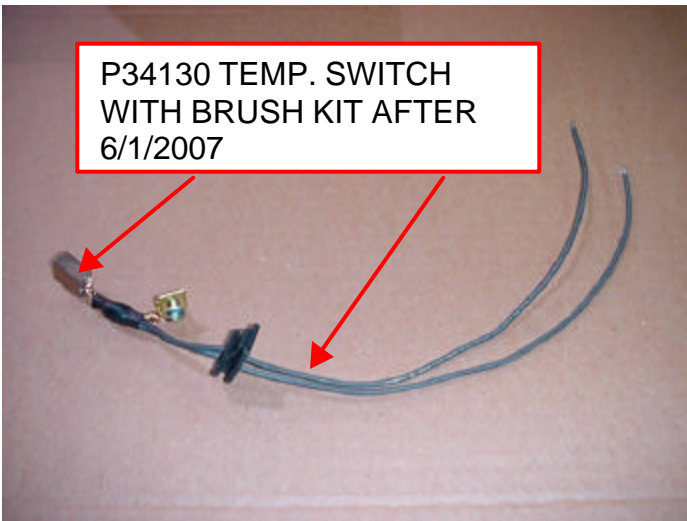

HYDRAULIC ASSEMBLY

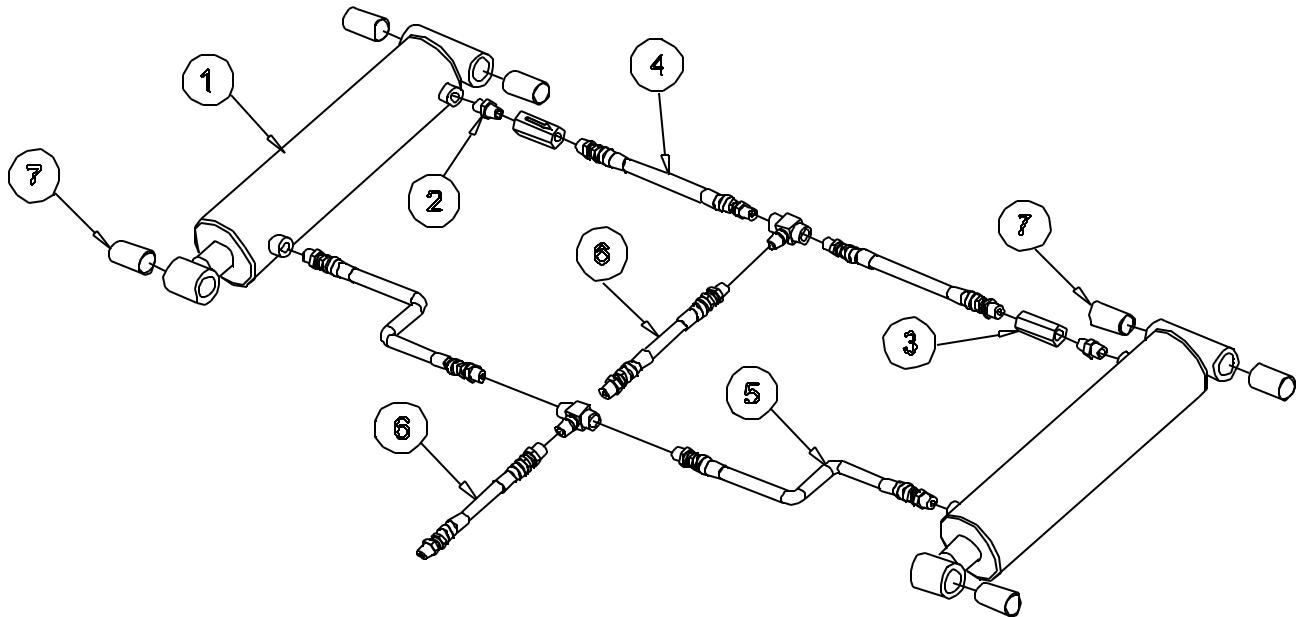

ITEM NO.	QTY.	PART NO.	DESCRIPTION
1	2	P33998	Cylinder
2	2	P33064	Pipe Nipple
3	2	P33619	2.8 GPM Flow Control Valve
4	2	AT-501-100-020	Hyd. Line Assy.
5	2	AT-501-100-041	Hyd. Line Assy.
6	2	AT-501-354-082	Hyd. Line Assy.
7	6	P43578	Greaseless Bushings

PIVOT PINS, BUSHINGS, SPRINGS

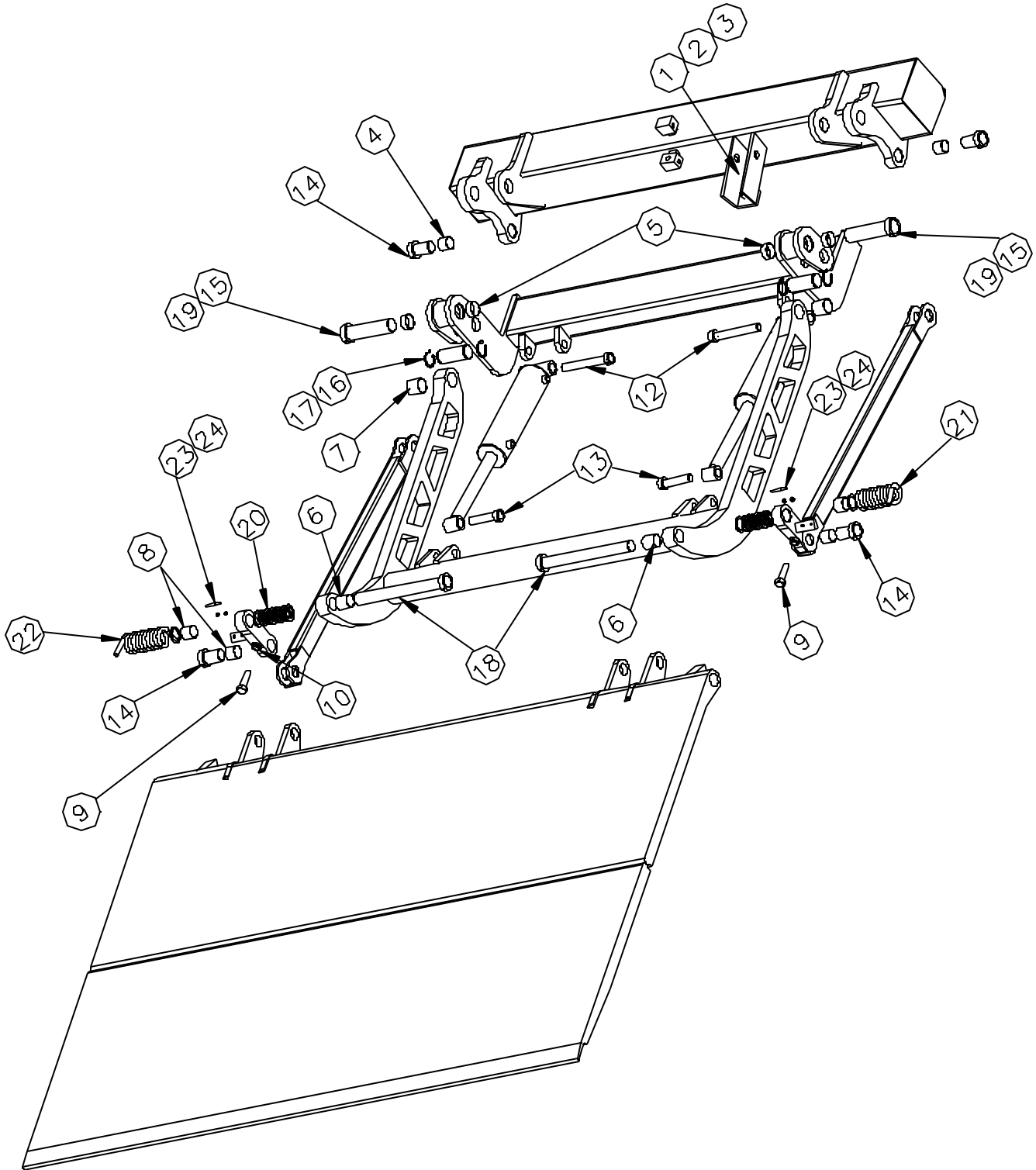

PIVOT PINS, BUSHINGS, SPRINGS

ITEM NO.	QTY.	PART NO.	DESCRIPTION	REMARKS
1	1	BA-711-114	Pivot Bracket	
2	1	P14517	Soc Head Set screw ½-13 x 2	
3	1	P23533	Hex Jam Nut ½-13	
4	2	P43582	BRG 1-1/2 ID x 1-5/8 OD x 1-1/4 LG.	
5	4	P43579	BRG 1-3/4 ID x 1-7/8 OD x 3/4 LG	
6	2	P43591	BRG 1-1/2 ID x 1-5/8 OD x 1-3/4 LG	
7	2	P43592	BRG 1-3/4 ID x 1-7/8 OD x 1-3/4 LG	
8	4	P43583	BRG 1-1/2 ID x 1-5/8 OD x 1-3/8 LG	
9	2	P10070	HHCS ¾-10 x 1-3/4 LG. Plated	
10	2	P22500	Nut Hex Jam ¾-10	
11	1	BA-711-104	Radius Arm Assembly	NOT SHOWN
12	2	AP-711-144	Shaft Base End	
13	2	AP-711-145	Shaft Rod End	
14	4	AP-711-042	Pin, Comp. Arm	
15	2	AP-711-044	Pin, Tilt Tube/Frame	
16	2	AP-711-045	Pin – Tilt Tube/ Ten Arm	
17	4	P24023	Retaining Ring	
18	2	BP-711-066	Platform Pin	
19	10	P26027	Nylon Washer Nom 2-1/8 x 1-3/4 x 1/8	
20	18	P26028	Nylon Washer Nom 2 OD x 1-1/2 id x 1/8	
21	1	P25206	RH Spring	
22	1	P25207	LH Spring	
23	2	P17566	U-Bolt ¼ x 1 x 1-3/4 LG	
24	4	P23502	Lock Nut ¼-20	
	6	P47532	Roll Pin ¼ x 2-1/4 LG	
	2	P47538	Roll Pin ¼ x 2-1/2 LG	

INSTALLING SAFETY DECALS

IMPORTANT !

All decals should be positioned so they can be seen with the LHLP-4500 both in operation and in rest position, and must NEVER be covered by components or elements of the vehicle (hooks, locks, cloths, etc.).

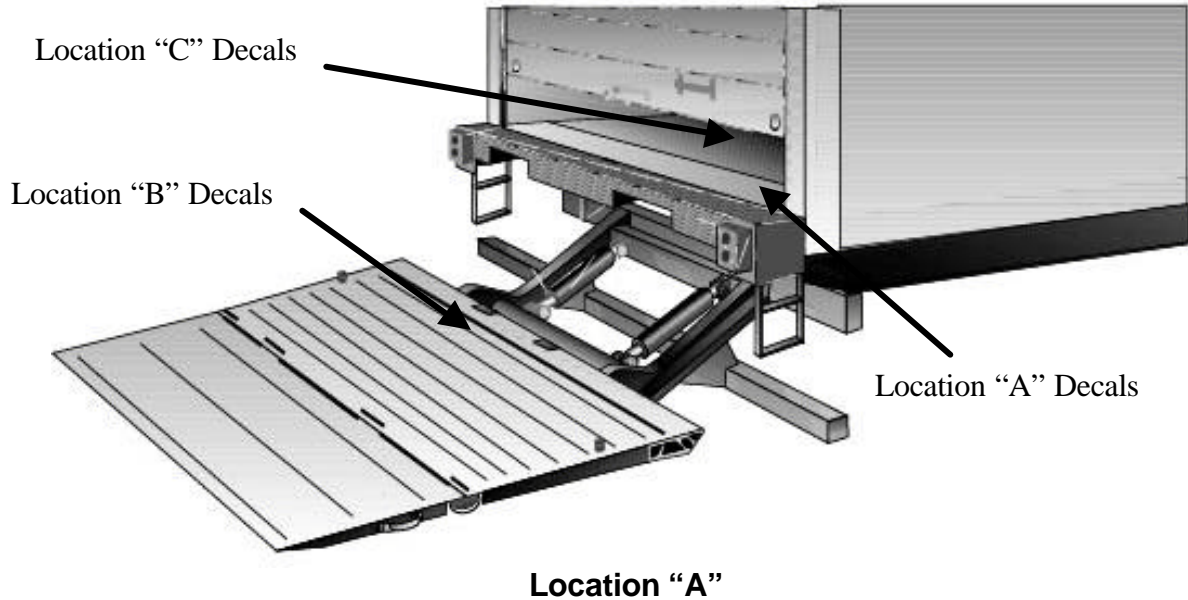

DESCRIPTION	DIMENSIONS	PART NO.
Urgent Warning	4 ½" x 4 ½"	P55199
Stand Clear	5" x 8"	P55198
After using Lift Gate	4" x 2"	P55201
READ & UNDERSTAND	4" X 3"	P55203
LHLP Operation Instructions	6" x 3"	P55329
CAUTION Maximum Load 4500 lbs	7" x 4"	P55344

Location "B" (on face of tension arm tube with gate UP)

DESCRIPTION	DIMENSIONS	PART NO.
Secure Latch	4" x 2"	P55202

Location "B" , on the UP/DOWN switch box

DESCRIPTION	DIMENSIONS	PART NO.
UP – DOWN POWER DOWN	3 1/8" X 1 3/8"	P55330

If any decals are missing or become damage, free replacements are always available from LEYMAN.

