

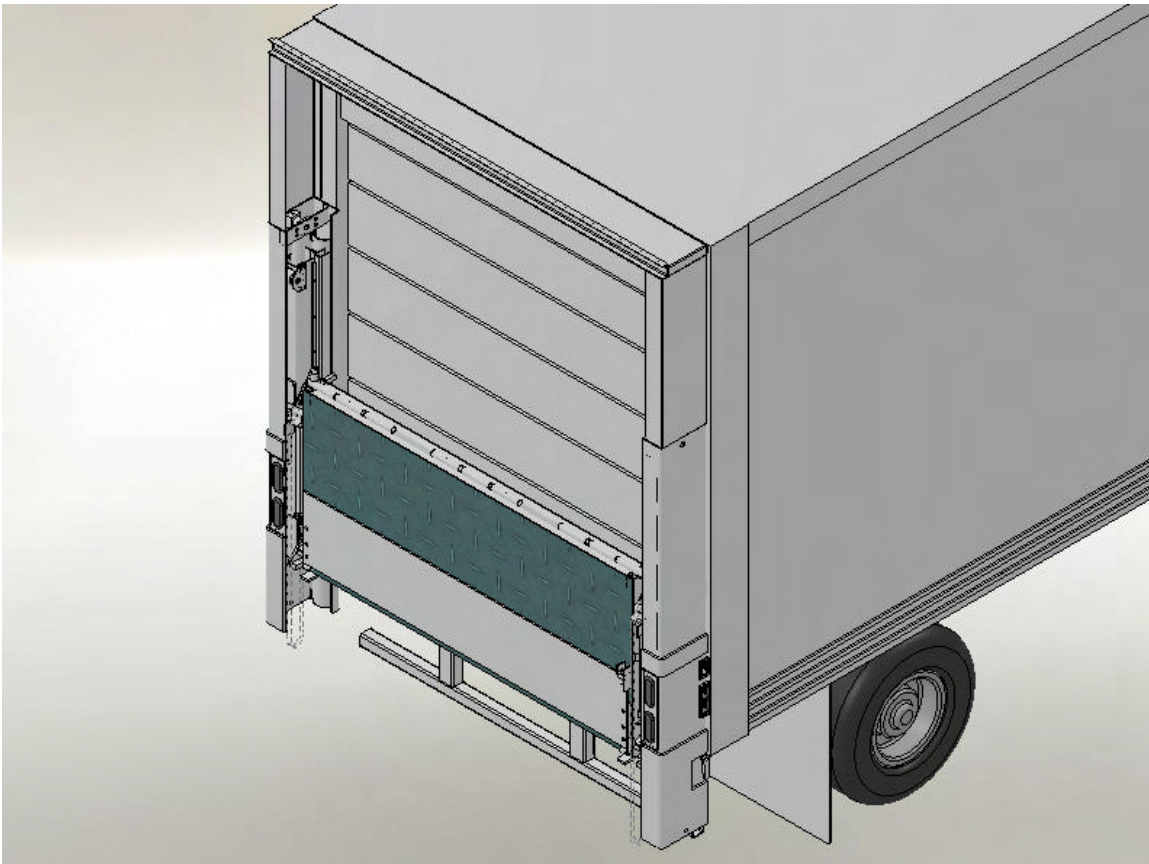

Owner's Manual  
**FXD68**  
**Fold-A-Vador®**  
**Rail Gate**



10900 Kenwood Road • Cincinnati, OH 45242  
Ph: 513.891.6210 • Toll-Free: 866.539.6261  
Fax: 513.891.4901  
[www.leymanlift.com](http://www.leymanlift.com) • [sales@leymanlift.com](mailto:sales@leymanlift.com)

# TABLE OF CONTENTS

---

Introduction	2
Words of Caution	3
General Terminology	4
Operating the Lift Gate	5
Operating the Dual Power Unit	6
Rec. Hydraulic Oil / Lift Gate Specs / Preventative Maintenance Schedule	7 – 8
Lubricating the Rollers	9
Trouble Shooting Chart / General Trouble Shooting Tips	10 – 14
Electrical Diagrams / Dual Power Unit Connections	15 – 18
Battery Hook Up / Grounding Recommendations	19 – 20
Maintenance Minder 2® Controller	21 – 23
Bleeding the Cylinders – Gravity Down and Power Down	24 – 26
Adjustment of the Equalizer Valve - Straightening The Tie Bar	27 – 28
Hydraulic Parts Replacement	29 – 31
Replacement Roller	32
Platform Pins and Bushings	33
Inner Mast Wear Pad / Fold Stop Adjustment	34
Switch Wiring Replacement	35 – 38
Power Unit Parts	39 – 42
Divider Valve / Flow Controls	43 – 44
Safety Warning Signs / Decals / Tags	45 – 48
Notes	49

# INTRODUCTION

---

This manual contains the operating procedures on the equipment your company is using that was manufactured by Leyman Manufacturing Corporation.

Past experience has indicated that it is most unwise to operate these units without proper instruction, which should be instituted by the purchaser.

While these products have certain safety features engineered into their design, they are all operated by human beings. Therein lies the problem of safety and one should always have caution in mind when operating this or any other machine that has parts that weigh several hundred pounds.

Again, let us remind you that there are moving parts on this product that weigh several hundred pounds. These parts, when not under proper control, can cause physical damage to operator. Because of the weights that are involved, carelessness and neglect of training can make these units dangerous.

Do not overload this product. Maintain it properly. Stand clear of moving parts. Operate as instructed.

This lift gate has a long life expectancy and will take some abuse. Use good judgment when operating this equipment.

## PLEASE FILL IN FOR YOUR RECORDS

<b>CUSTOMER:</b>	_____
<b>MODEL:</b>	_____
<b>CAPACITY:</b>	_____
<b>TYPE:</b>	_____
<b>POWER:</b>	<u>12 VOLT</u>
<b>PLATFORM:</b>	_____
<b>SERIAL:</b>	_____
<b>OPTIONS</b>	_____
	_____
	_____
	_____
<b>MAXIMUM HEIGHT:</b>	56"
<b>HYDRAULIC PRESSURE:</b>	<b>AT BY-PASS</b> 2,500 PSI AT THE PUMP
<b>AMP DRAW:</b>	<b>AT BY-PASS</b> 235, UNLOADED 135
<b>GRAVITY DOWN OR POWER DOWN</b>	

**WHEN PLACING PARTS ORDER, YOU WILL NEED  
THE SERIAL# AND MODEL# OF THE GATE.**

# WORDS OF CAUTION

---

1. BEFORE ANY MAINTENANCE IS PERFORMED ON THIS UNIT, READ AND UNDERSTAND THIS MANUAL COMPLETELY.
2. DO NOT STAND ON OR BEHIND THE PLATFORM WHEN OPERATING GATE IN THE FOLDED POSITION.
3. DO NOT STAND IN FRONT OF THE PLATFORM WHEN LOWERING FROM VERTICAL POSITION OR OPERATING IN ANY MANNER.
4. MAKE SURE THE GROUND IS CLEAR UNDER THE PLATFORM WHEN LOWERING.
5. CHECK THE AREA AROUND THE UNIT FOR ANY PERSONS BEFORE OPERATING THE LIFT GATE.
6. NEVER EXCEED THE RATED LOAD CAPACITY OF THIS GATE. DO NOT OVERLOAD - MAXIMUM RATED CAPACITY IS BASED ON AN EVENLY DISTRIBUTED LOAD OVER THE PLATFORM FLAT SURFACE.
7. ALWAYS LOAD AS CLOSE TO THE CENTER OF THE PLATFORM AND AS CLOSE TO THE CENTER OF THE TRUCK SILL AS POSSIBLE.
8. DO NOT ALLOW PERSONS TO OPERATE THE UNIT UNLESS THEY HAVE BEEN PROPERLY TRAINED TO DO SO.
9. USE ONLY FACTORY AUTHORIZED PARTS FOR REPLACEMENT.

THIS MANUAL REFLECTS MOST CHANGES AND UPDATES OF MATERIALS THAT ARE COMMON TO THIS TYPE OF LIFT GATE. SOME MAY DIFFER DUE TO INDIVIDUAL CUSTOMER REQUIREMENTS. THIS MANUAL HAS BEEN ESTABLISHED TO REFLECT THE COMMON ITEMS.

**WARNING:** THIS GATE HAS POLYMER GREASELESS BEARINGS IN THE PLATFORM PIVOTS, AND CYLINDER. WHEN WELDING BE SURE TO GROUND DIRECTLY TO THE COMPONENT BEING WELDED.

# GENERAL TERMINOLOGY

---

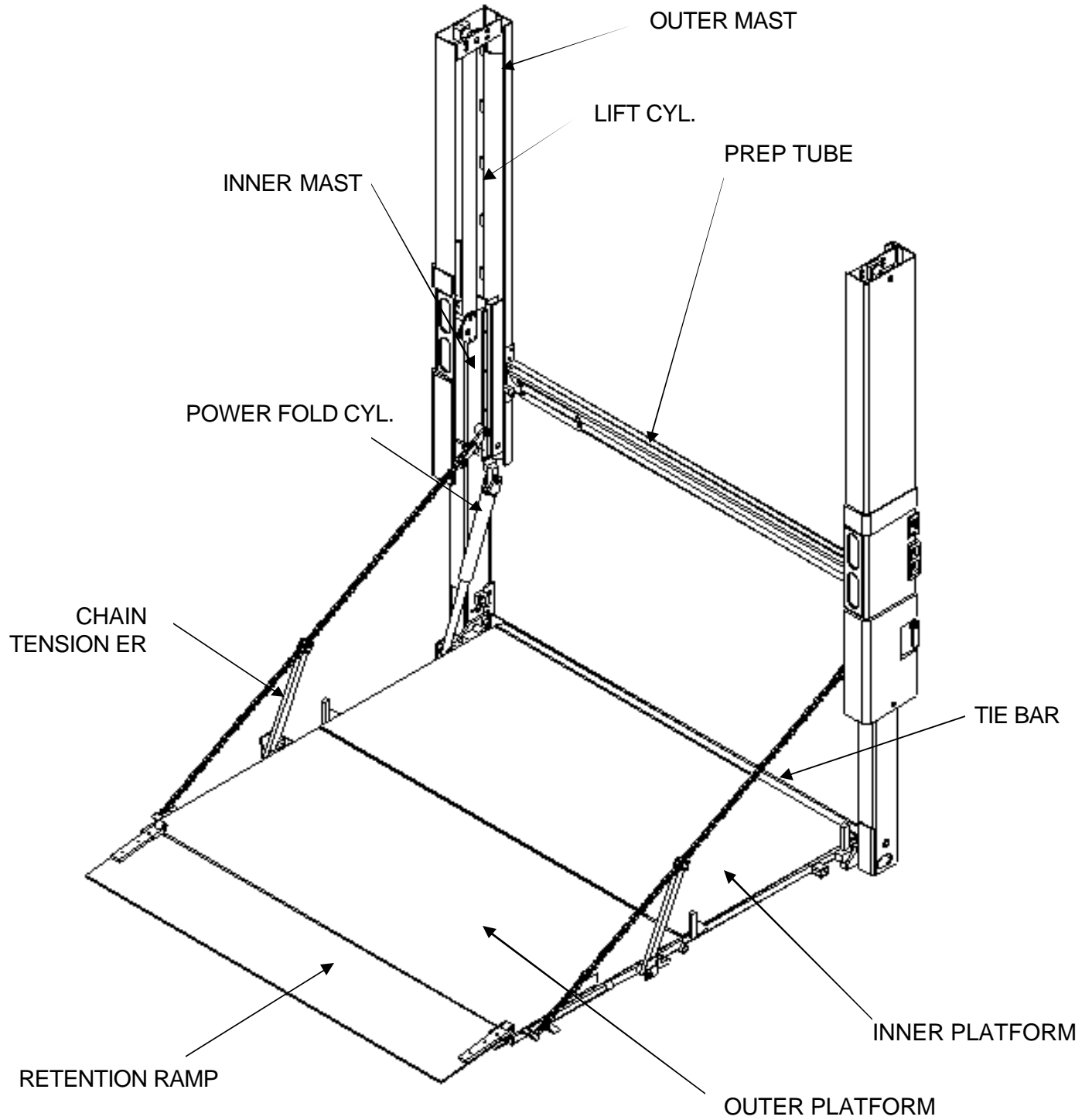

# OPERATING THE LIFT GATE

---

Before operating the lift, read and understand this decal, Urgent Warning decal and Owner's manual.

Do not stand behind lift gate while unfolding or using platform.

## **To unfold the platform from over-the-road position**

1. Toggle the DOWN switch to lower platform.
2. Lower the platform until arrow indicates FOLD / UNFOLD region. Toggle both UNFOLD switches. Gate will unfold.

## **To dock load**

1. Toggle the DOWN switch to lower platform.
2. Continue lowering until platform rests on dock level stops.

**WARNING!** Never use the platform as a “bridge” to a dock or other vehicle. Platform can fold unexpectedly and cause injury.

## **To lower platform, use the down switch only.**

## **To raise platform, use the up switch only.**

## **Safe loading of platform**

1. Cart stop or retention ramp must be in place whenever lifting or lowering a load. Also, see the Urgent Warning decal.

## **To fold platform**

1. Raise the platform until arrow indicates FOLD / UNFOLD region. Then toggle both FOLD switches until platform completely folds. Raise platform until gate hits Up Stops and arrow indicates locked position. Do not move vehicle unless gate is in locked position.

# OPERATING THE DUAL POWER UNIT

---

Use the power unit Selector Switches to choose which power unit runs using the gate switches. Primary Power Unit is in front. Secondary Power Unit is in the rear. The emergency Walk-Around Pushbutton control will only operate the Secondary Power Unit. Switches MUST be to the right for proper Walk-Around Pushbutton operation. The Maintenance Minder 2<sup>®</sup> Controller functions with both power units. If you wish to put equal operating time on each power unit, use the Maintenance Minder 2 service intervals (3000 lifts) as the guide for changing the power unit Selector Switches.

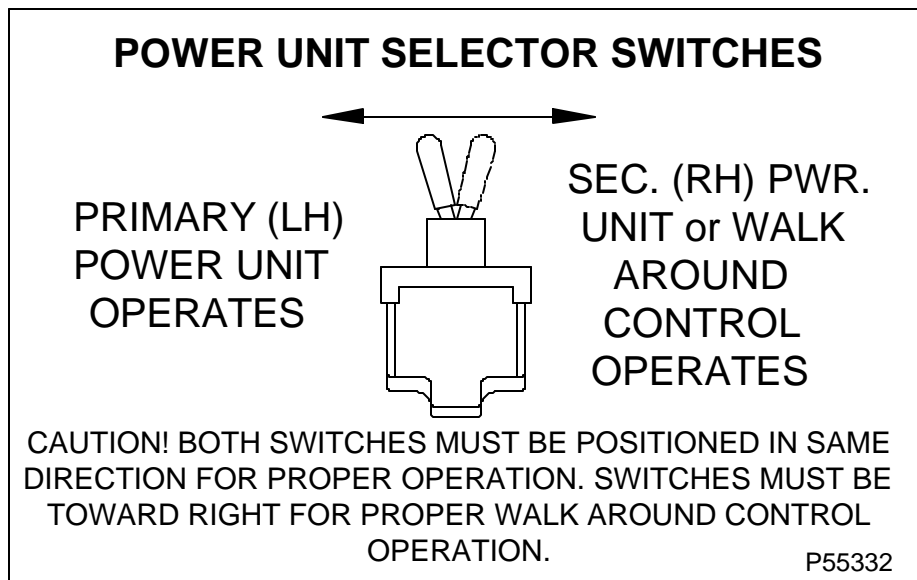

# RECOMMENDED HYDRAULIC OILS

HYDRAULIC OILS	MANUFACTURER	TYPE	TEMP. RANGE
Level 1 Normal Conditions	Mobile	DTE 11	-15° F to + 150° F
	Shell	TELLUS-T15	-15° F to + 150° F
	Chevron	RYKON ISO-15	-15° F to + 150° F
Level 2 Cold Conditions	Mobile	AERO-HFA	-50° F to + 80° F
	Shell	AERO FLUID#4	-50° F to + 80° F
	Chevron	AVIATION-A	-50° F to + 80° F
HYDRAULIC TANK CAPACITY			
2 ½ gallons			
LUBRICATION			
Grease	Militec #1 (or Lithium base NLGI grade 1 grease)		
Rollers at Inner Masts	CAUTION! Do not over-grease to avoid seal damage		
Hinge Barrels (center of platform)	W.W. Grainger – Part #6Y834 – Needle Nose Adapter		
Retention Ramp hold-up tab shaft	W.W. Grainger – Part #6Y834 – Needle Nose Adapter		
Dry Lubricant, if needed	ZEP45 (do not use corrosive lubricants like WD40, etc.)		

# LIFT GATE SPECIFICATION

BATTERIES
Two (2) 12 V D.C. Group 31 Heavy Duty Lead Acid Dual Purpose or AGM
ELECTRICAL COMPONENTS CONNECTIONS
Use Fluid Film Rust & Corrosion Protection by Eureka, except on Start Solenoid On Start Solenoid, use Color Guard by Loctite, or Liquid Electrical Tape
AMPERAGE DRAW OF MOTOR
When raising platform (empty) approximately 140 AMPS @ 13.5 volts. At bypass approximately 240 AMPS @ 13.5 volts
LIFTING PRESSURE SETTING
With platform at floor level and pump in bypass 2500 PSI Power down circuit in bypass 500 PSI
MINIMUM VEHICLE FLOOR HEIGHT LADEN
With Inner Platform 42" – vehicle floor height 46"
MAXIMUM VEHICLE FLOOR HEIGHT UNLADEN
With Inner Platform 42" – vehicle floor height 56"
APPROXIMATE TIMES EMPTY AT 80° F WITH 2 GROUP 31 BATTERIES
Time up: 22 – 24 seconds Time down(gravity down): 12 –14 seconds Time down(power down): 14 – 16 seconds

# PREVENTATIVE MAINTENANCE SCHEDULE

## MAINTENANCE by CYCLES

### FXD MODELS

DATE:

CUSTOMER		GATE MODEL #	
LOCATION		GATE SERIAL #	
VEHICLE #		SERVICED BY	

v = OK                      X = REPAIR                      A = ADJUSTED                      N = NOT APPLICABLE

3000	MOTOR / PUMP COMPONENTS	3000	MOTOR / PUMP COMPONENTS
	Check batteries for corroded, loose or broken connections		Check charge line/power line for corroded, loose or broken connections
	Check batteries for proper voltage level and charging		Check amp draw of motor with fully charged batteries and tight clean connections
	Check all wiring in pump box for corroded, loose or broken connections		Check all ground wires for corroded, loose or broken connections
	Check solenoid valves for proper operation		Check pressure setting of relief valve (two valves in power down pumps)
	Check reservoir for proper oil level " <b>Gravity Down</b> " - Gate open and down on the ground, 2" from top of tank for dual unit		After all wiring connections in pump and battery box have been cleaned, protect from corrosion using materials listed in Lift Gate Specification section.
	Check reservoir for proper oil level " <b>Power Down</b> " - Gate open and up at floor level, 2" from top of tank for dual unit		Operate both power units to verify proper operation.
	Inspect circuit breakers and fuses for proper operation		Check all fittings / hoses in power unit for tightness and leaks

3000	STRUCTURAL COMPONENTS	3000	STRUCTURAL COMPONENTS
	Check switches for proper operation, check connections for tightness and corrosion		Remove hydraulic guard for fold cylinder line and check for loose / missing clamps, frayed lines , and proper alignment
	Check all fittings/hoses on cylinders for tightness and leaks		Check lift gate for proper operation up and down
	Check fold cylinder for leaks / worn rod seal		Check lift gate for proper operation folding and unfolding
	Check for broken/missing roll pins at fold cylinder, and primary/secondary platform pin		Check for impact damage on inner/outer masts
	Check snap rings on lift and fold cylinder pins		Check for loose / missing bolts at platform pins , platform chains, rollers, and bottom cylinder pins
	Check for broken torsion spring at platform		Check and re-weld any cracked / broken welds
	Check aluminum platform for loose bolts on side brackets and threaded plugs at hinge pins		Replace all safety and warning labels as needed

3000	LUBRICATION		PERIODICAL CHECK LIST
	Grease roller bearings at grease holes on roller shaft with recommended grease. DO NOT OVER-GREASE	<b>12000</b>	Check all pivot point bushings for wear or damage
	Grease primary / secondary platform hinge pin at grease holes , plus Retention Ramp Hold-up Tab shaft support.	<b>16000</b>	Flush hydraulic system and change hydraulic oil
			Clean and repaint as necessary

### MAINTENANCE MINDER<sup>2</sup> READINGS MENU 2

Screen 1 # Lifts	Screen 3 Service Faults	Screen 4 Low Voltage Faults	Screen 6 High Temperature Faults

Check owner's manual for proper hydraulic oil, motor amp draw and pressure setting of power unit

Revised July, 2011

# LUBRICATING THE ROLLERS

---

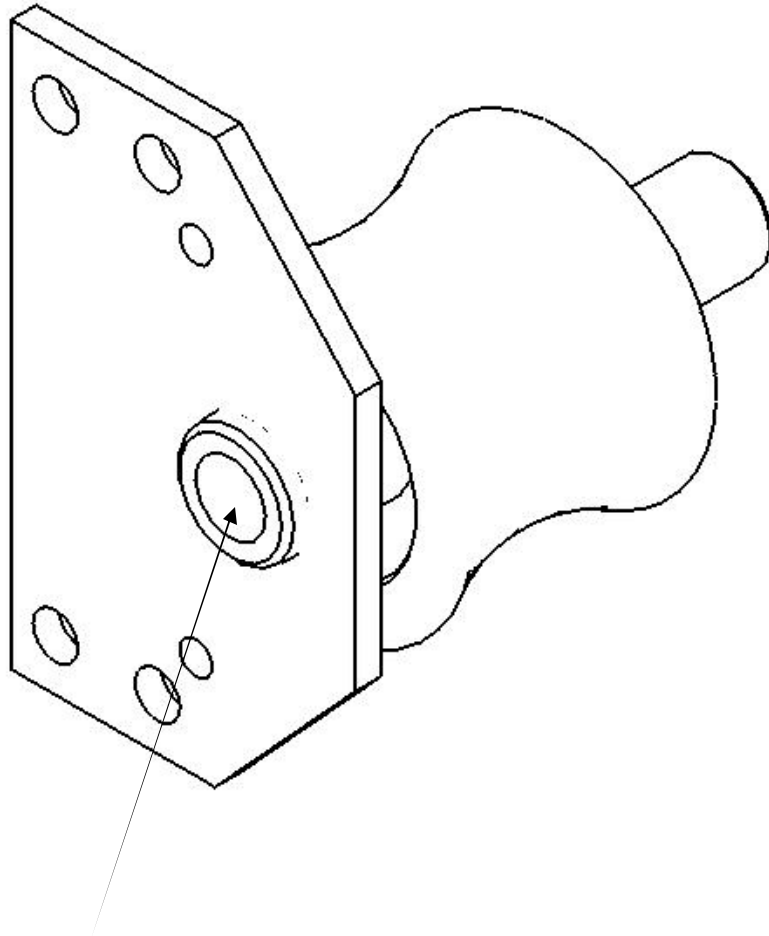

Lubricate roller through grease fitting mounted on roller shaft.  
(Picture shows isolated roller assembly but it can be greased when  
mounted on Inner Mast). **CAUTION! DO NOT OVER-GREASE  
ROLLERS OR DAMAGE TO BEARING SEALS MAY OCCUR.**

# TROUBLE SHOOTING CHART

---

The following troubleshooting chart covers the standard dual power unit used with the FXD®.

PROBLEM	PROBABLE CAUSE	REMEDY
Platform will not go up or reach the floor of the vehicle.	<ol style="list-style-type: none"> <li>1. Battery is low.</li> <li>2. Slave line is disconnected or connections are loose (battery and motor).</li> <li>3. Insufficient oil in power unit tank.</li> <li>4. Poor switch connections.</li> </ol>	<ol style="list-style-type: none"> <li>1. Recharge the battery.</li> <li>2. Connect the slave line properly.</li> <li>3. Fill the power unit tank.</li> <li>4. Clean and check switch connections in power unit box.</li> </ol>
Platform will not lower.	<ol style="list-style-type: none"> <li>1. Battery is low.</li> <li>2. Poor switch connections.</li> <li>3. Check lowering valve ("B" valve in GD, "D" valve in PD).</li> </ol>	<ol style="list-style-type: none"> <li>1. Recharge the battery.</li> <li>2. Clean and check switch connections in power unit box.</li> <li>3. Clean/replace as necessary. Try manual overrides.</li> </ol>
Platform does not go up smoothly.	<ol style="list-style-type: none"> <li>1. Insufficient oil in power unit tank.</li> <li>2. Air lock in hydraulic system.</li> <li>3. Dirt or foreign material in guides.</li> <li>4. Mechanical wear.</li> </ol>	<ol style="list-style-type: none"> <li>1. Fill tank.</li> <li>2. Run platform to stop. Open up vent plugs in each cylinder while power unit is running. Close vent plugs and refill the tank.</li> <li>3. Clean guides with steam and check for excessive wear, obstructions, and burrs.</li> <li>4. Replace worn parts.</li> </ol>
Platform creeps down.	<ol style="list-style-type: none"> <li>1. Hydraulic leak.</li> <li>2. Cylinder piston seal failing.</li> <li>3. Check lowering valve ("B" valve in GD, "D" valve in PD).</li> </ol>	<ol style="list-style-type: none"> <li>1. Check all hoses and fittings.</li> <li>2. Replace cylinder or seals.</li> <li>3. Clean / replace as necessary. Manual over-ride must be IN and turned CLOCKWISE.</li> </ol>
Platform goes down slowly.	<ol style="list-style-type: none"> <li>1. Incorrect hydraulic oil in system for cold weather.</li> <li>2. Excessive wear of mechanical components.</li> <li>3. Restriction in hydraulic system.</li> </ol>	<ol style="list-style-type: none"> <li>1. Use recommended viscosity for hydraulic oil.</li> <li>2. Insure free movement of all mechanical parts.</li> <li>3. Check all hydraulic system components.</li> </ol>
Platform goes up crooked.	<ol style="list-style-type: none"> <li>1. Equalizer valve is out of adjustment.</li> <li>2. Air trapped in one of the cylinders.</li> <li>3. Tie bar is bent.</li> </ol>	<ol style="list-style-type: none"> <li>1. Adjust equalizer valve.</li> <li>2. Bleed air out of the cylinders.</li> <li>3. Straighten the tie bar.</li> </ol>

## TROUBLE SHOOTING CHART (Cont.)

---

The following troubleshooting chart covers the standard dual power unit used with the FXD<sup>®</sup>.

PROBLEM	PROBABLE CAUSE	REMEDY
Platform comes down crooked.	<ol style="list-style-type: none"> <li>1. Dirt in flow control, not adjustable.</li> <li>2. Restriction in hydraulic line for lift cylinder.</li> <li>3. Mechanical bind on one side of gate.</li> <li>4. Tie bar is bent.</li> </ol>	<ol style="list-style-type: none"> <li>1. Clean / replace flow control valves (matched pair) as necessary.</li> <li>2. Clean hydraulic line and bleed cylinders.</li> <li>3. Clean and inspect inner mast and rollers. Check wear of parts and replace if necessary.</li> <li>4. Straighten tie bar.</li> </ol>
Gate will not lift the rated load.	<ol style="list-style-type: none"> <li>1. Hydraulic pump is worn.</li> <li>2. Battery is too low.</li> <li>3. Pressure relief valve not set properly at 2500 psi.</li> </ol>	<ol style="list-style-type: none"> <li>1. Change the pump.</li> <li>2. Recharge the battery to full charge.</li> <li>3. Adjust pressure relief valve.</li> </ol>
Pump will not operate.	<ol style="list-style-type: none"> <li>1. Battery too low.</li> <li>2. Electrical hookup to motor not making contact.</li> <li>3. Control switches are not properly connected at power unit.</li> <li>4. Maintenance Minder 2<sup>®</sup> Controller has shut down the system due to low voltage. Must maintain 8 volts minimum under load.</li> </ol>	<ol style="list-style-type: none"> <li>1. Recharge the battery and check to be sure that the slave line has a good connection.</li> <li>2. Clean connections and re-tighten.</li> <li>3. Check switches for proper connections. Check for proper operation.</li> <li>4. Use the "Last Lift Menu" to read maximum and minimum voltages. Recharge battery.</li> </ol>

# GENERAL TROUBLE SHOOTING TIPS

---

## LIFTGATE

1. This gate can run up or down crooked 1" to 1-1/2" without hurting the gate.
2. Equalizer Valve – for adjusting the up stroke only, when the gate is loaded.
3. Flow Control Valves – for controlling the down stroke only. Clean or replace in sets.
4. Bent Tie Bar – how to tell if it is bent. Raise the platform to the full up position (level with the truck floor). Push the down switch. If the tie bar is bent, one side will always drop quicker than the other side. If bent, see the Maintenance Manual for information about the procedure. **BEFORE ADJUSTING OR ATTEMPTING TO FIX ANY OF THE FOUR ITEMS LISTED ABOVE, CHECK THE FOLLOWING FIRST:**
  - a. Check for bent inner mast.
  - b. Check to see if the back edge of the platform is hitting or binding against the floor level tube.
5. Premature motor failure is almost always caused by low batteries – batteries without the capacity to maintain the correct voltage during the operation of the gate.
6. Inadequate grounding is also a major reason for motor failure.

## EMERGENCY OPERATION – POWER UNIT – GRAVITY DOWN

Operation desired	Symptoms	Directions to identify problem.	Did the gate do the desired operation?	Diagnosis
Up	The gate does not go up but the motor runs	Manually override two-way locking valve "B" (See figure on next page for overridden and non overridden positions)	Yes	"B" Valve or wiring is defective. Return valve to non overridden position once you have the gate in the stored position.
			No	Pump is bad.
Down	The gate does not go down	Manually override two-way locking valve "B" (See figure on next page for overridden and non overridden positions)	Yes	"B" Valve or wiring is defective. Return valve to non overridden position once you have the gate in the stored position.
			No	"A" Valve or wiring is defective.
Fold	The gate does not fold but the motor runs	Manually override two-way locking valve "C" (See figure on next page for overridden and non overridden positions)	Yes	"C" Valve or wiring is defective. Take the gate to the stored position using the push and hold override button.
			No	Pump is bad.
Unfold	The gate does not unfold	Manually override Two-way locking valve "C" (Check that platform has cleared the unfold locks on both sides).	Yes	"C" Valve or wiring is defective. Take the gate to the stored position using the push and hold override button.
			No	"A" Valve or wiring is defective.

# GENERAL TROUBLE SHOOTING TIPS (Cont.)

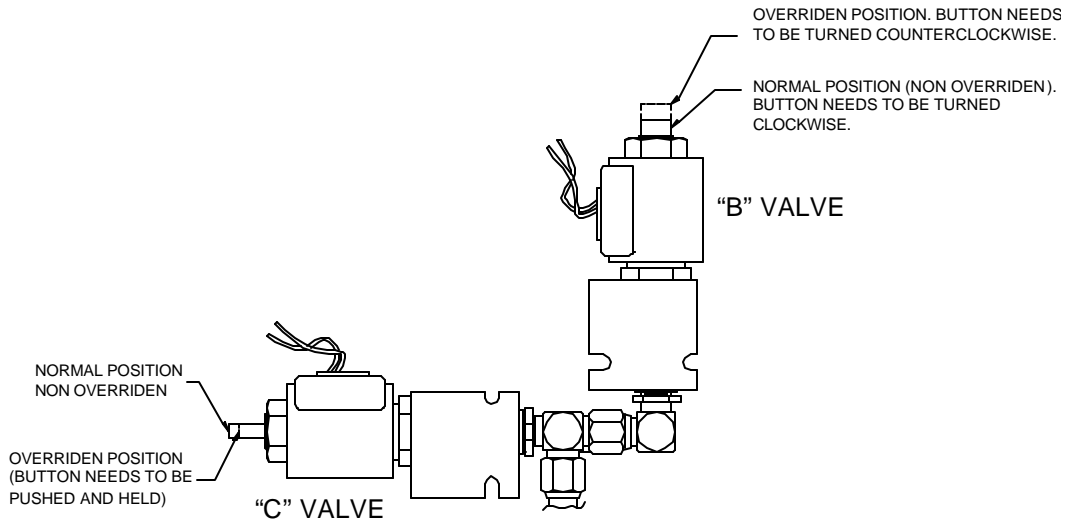

## EMERGENCY OPERATION – POWER UNIT – POWER DOWN

Operation desired	Symptoms	Directions to identify problem.	Did the gate do the desired operation?	Diagnosis
Up	The gate does not go up but the motor runs	Manually override two-way locking valve "B" (See figure on next page for overridden and non overridden positions)	Yes	"B" Valve or wiring is defective. Return valve to non overridden position once you have the gate in the stored position.
			No	Pump is bad.
Down	The gate does not go down but the motor runs.	Manually override one-way locking valve "D" (See figure on next page for overridden and non overridden positions)	Yes	"D" Valve or wiring is defective. Return valve to non overridden position once you have the gate in the stored position.
			No	"A" Valve or wiring is defective.
Fold	The gate does not fold but the motor runs	Manually override two-way locking valve "C" (See figure on next page for overridden and non overridden positions)	Yes	"C" Valve or wiring is defective. Take the gate to the stored position using the push and hold override button.
			No	Pump is bad.
Unfold	The gate does not unfold	Manually override Two-way locking valve "C" (Check that platform has cleared the unfold locks on both sides).	Yes	"C" Valve or wiring is defective. Take the gate to the stored position using the push and hold override button.
			No	"A" Valve or wiring is defective.

# GENERAL TROUBLE SHOOTING TIPS (Cont.)

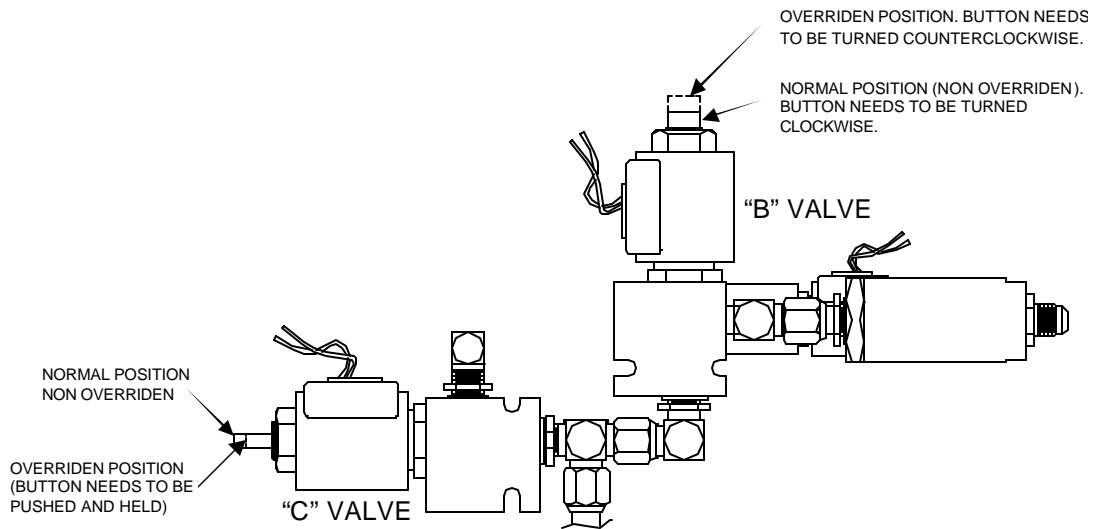
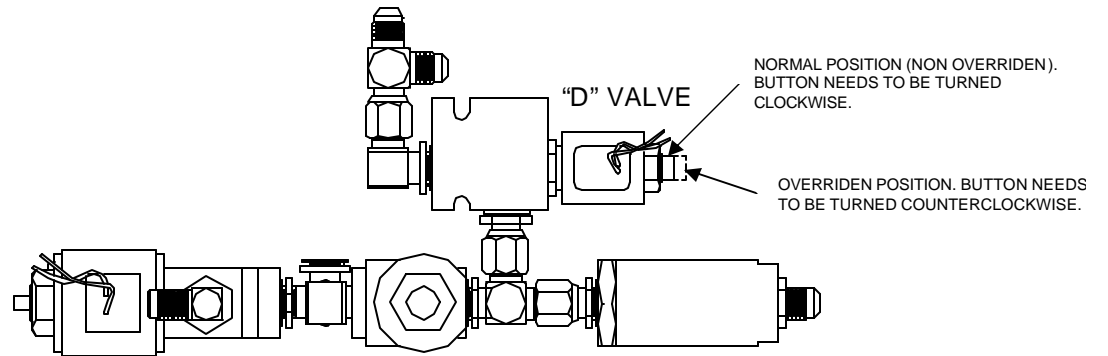

# ELECTRICAL DIAGRAM DUAL GRAVITY DOWN

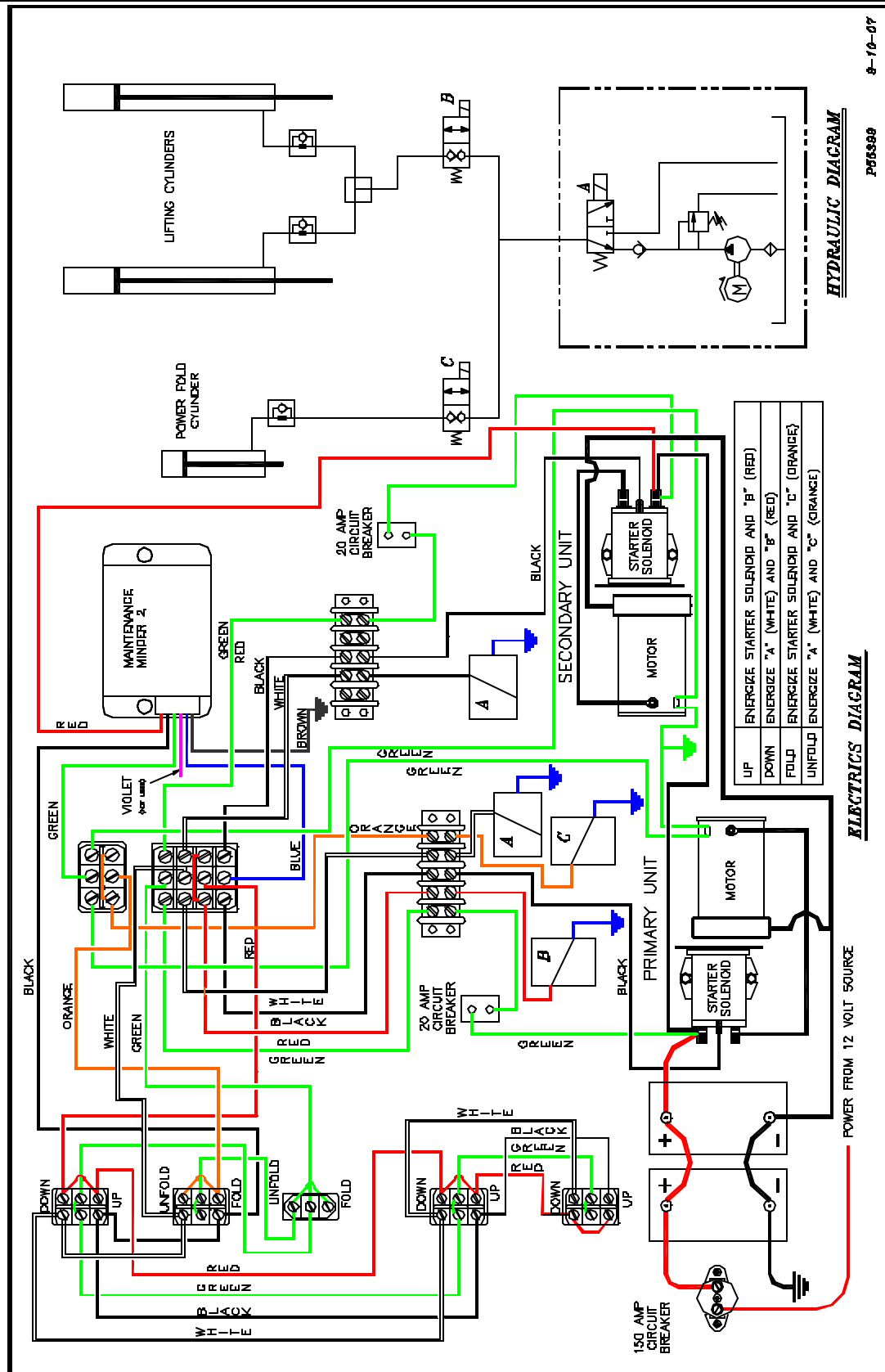

8-10-07

PG3399

# ELECTRICAL DIAGRAM DUAL POWER DOWN

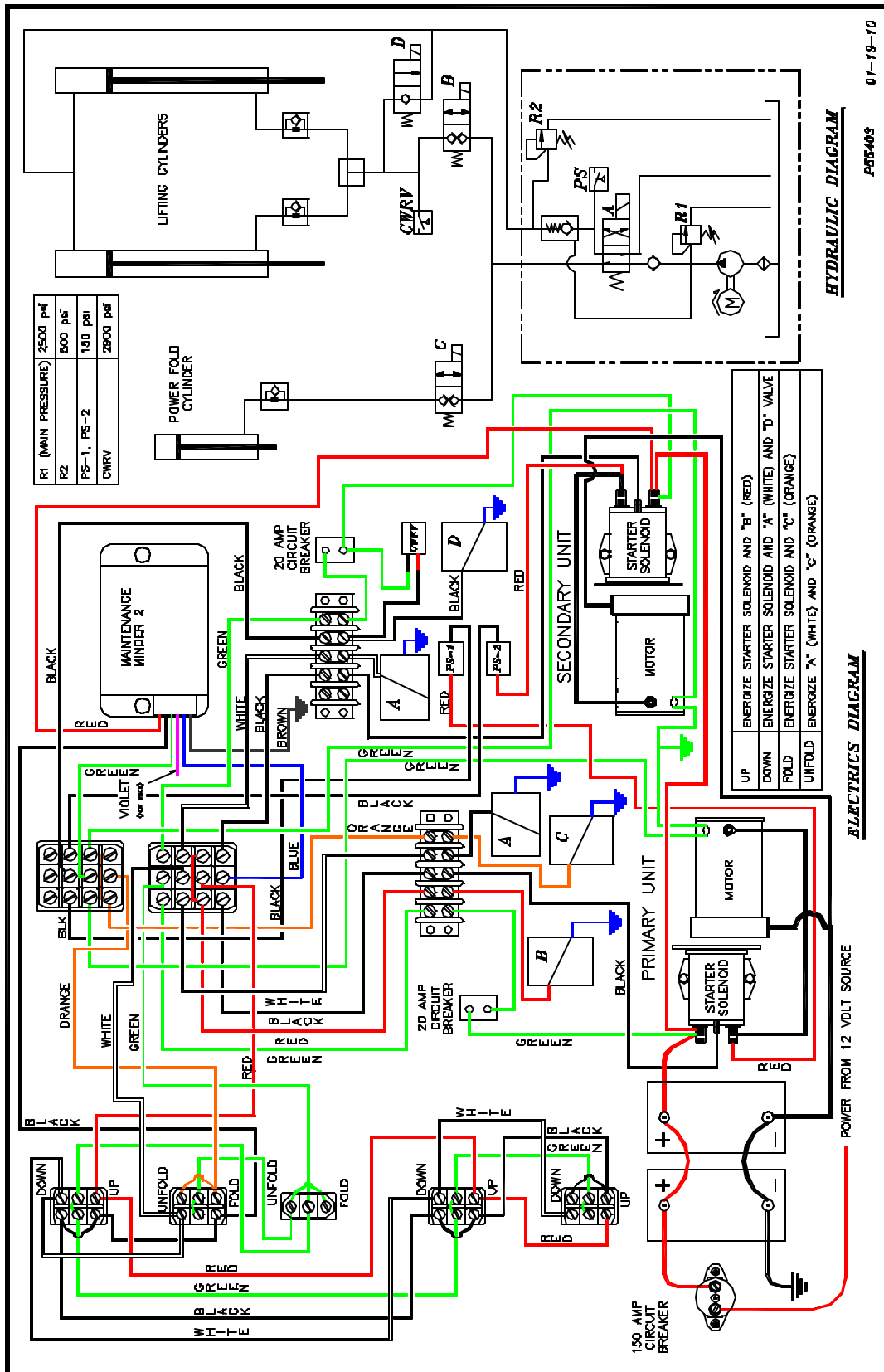

# DUAL POWER UNIT CONNECTIONS

## CONNECTING THE GATE SWITCHES TO POWER UNIT – GRAVITY DOWN

ROUTE THE CABLE FROM THE GATE SWITCHES INTO THE POWER UNIT ENCLOSURE. FOLLOW THE DUAL GRAVITY DOWN DIAGRAM. THE ORANGE, GREEN, WHITE, AND RED WIRES WITH FORK TERMINALS CONNECT TO THE CENTER COLUMN OF THE SELECTOR SWITCHES. USE ONLY THE OPEN POSITIONS ON THE CENTER SCREWS. MATCH COLOR TO COLOR ACROSS THE ROWS FOR PROPER OPERATION. THE BLACK WIRE IS BUTT CONNECTED TO THE BLACK WIRE FROM THE MAINTENANCE MINDER 2.

NOTE: THE SELECTOR SWITCH BRACKET CAN BE UNBOLTED TO MAKE THE CONNECTIONS EASIER TO ACCESS.

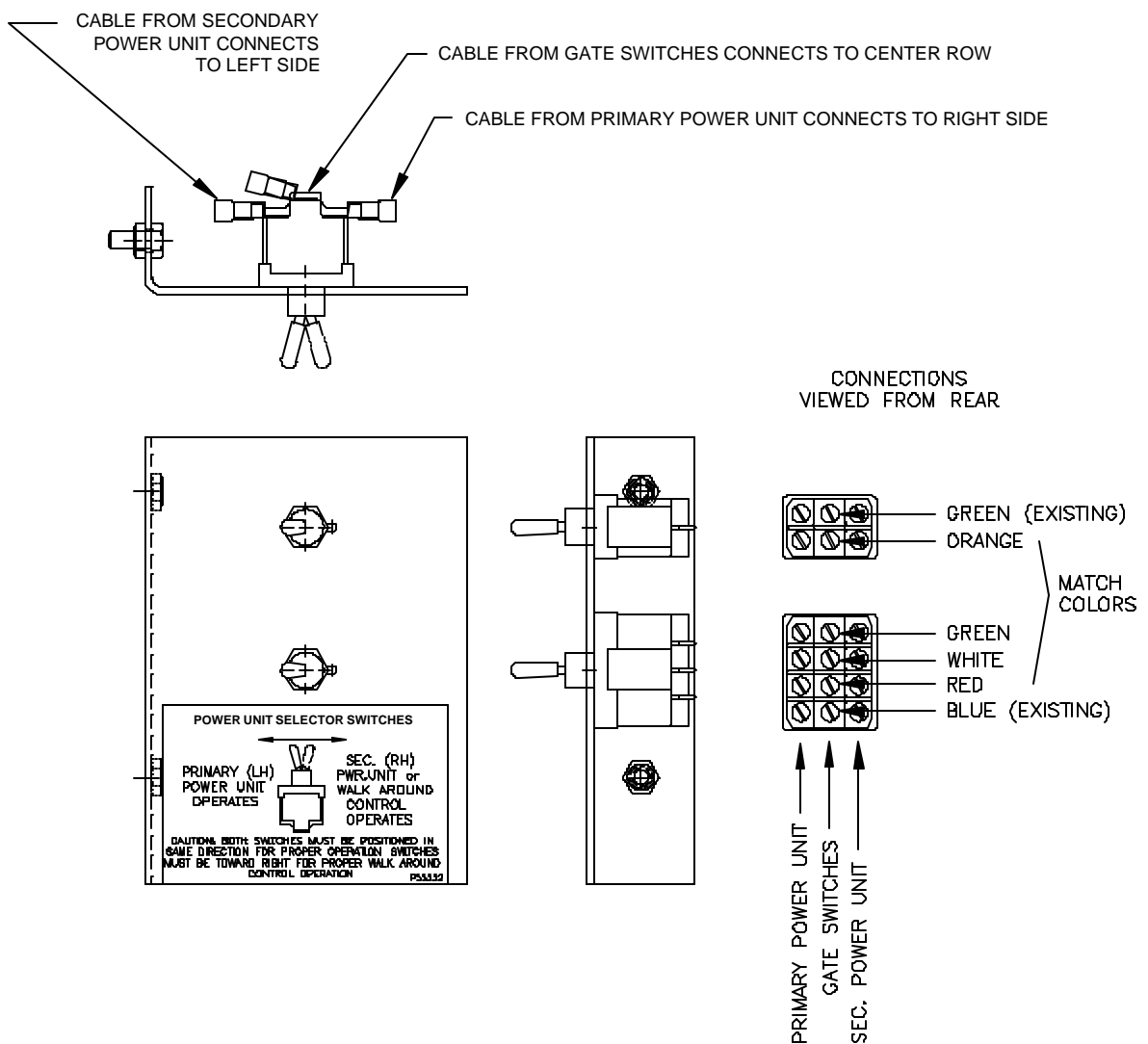

# DUAL POWER UNIT CONNECTIONS (Cont.)

## CONNECTING THE GATE SWITCHES TO POWER UNIT – POWER DOWN

ROUTE THE CABLE FROM THE GATE SWITCHES INTO THE POWER UNIT ENCLOSURE. FOLLOW THE DUAL POWER DOWN DIAGRAM. THE ORANGE, GREEN, WHITE, AND RED WIRES WITH FORK TERMINALS CONNECT TO THE CENTER COLUMN OF THE SELECTOR SWITCHES. USE ONLY THE OPEN POSITIONS ON THE CENTER SCREWS. MATCH COLOR TO COLOR ACROSS THE ROWS FOR PROPER OPERATION. THE BLACK WIRE IS BUTT CONNECTED TO THE BLACK WIRE FROM THE MAINTENANCE MINDER 2.

NOTE: THE SELECTOR SWITCH BRACKET CAN BE UNBOLTED TO MAKE THE CONNECTIONS EASIER TO ACCESS.

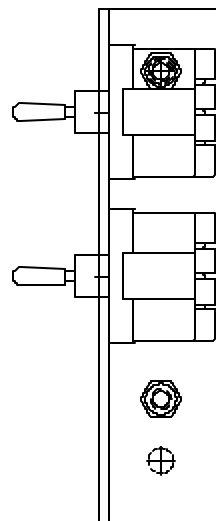
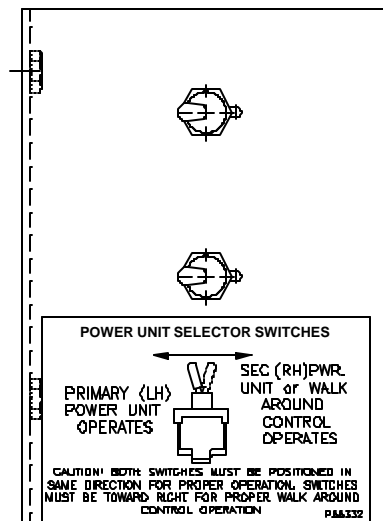
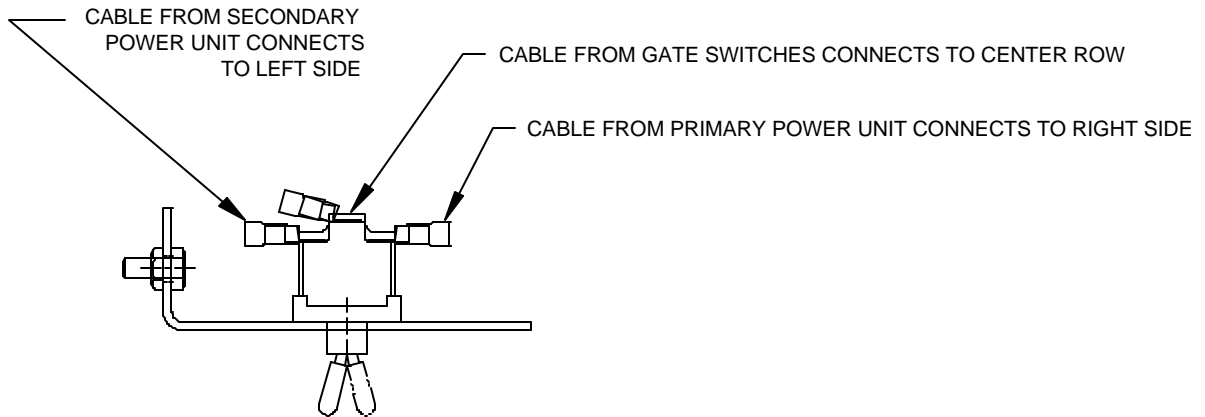

CONNECTIONS VIEWED FROM REAR

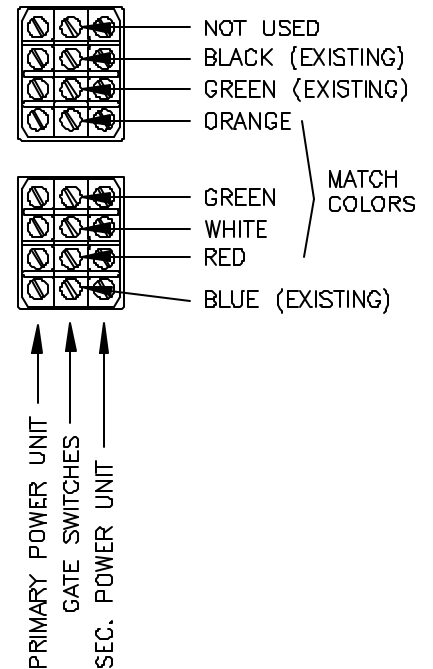

# BATTERY HOOK UP

We recommend batteries with the following specifications:  
12 Volt Heavy Duty Lead Acid Dual Purpose or AGM  
B.C.I. Group – Size 31  
Terminal Type – TS  
Cold Cranking Amps - 580

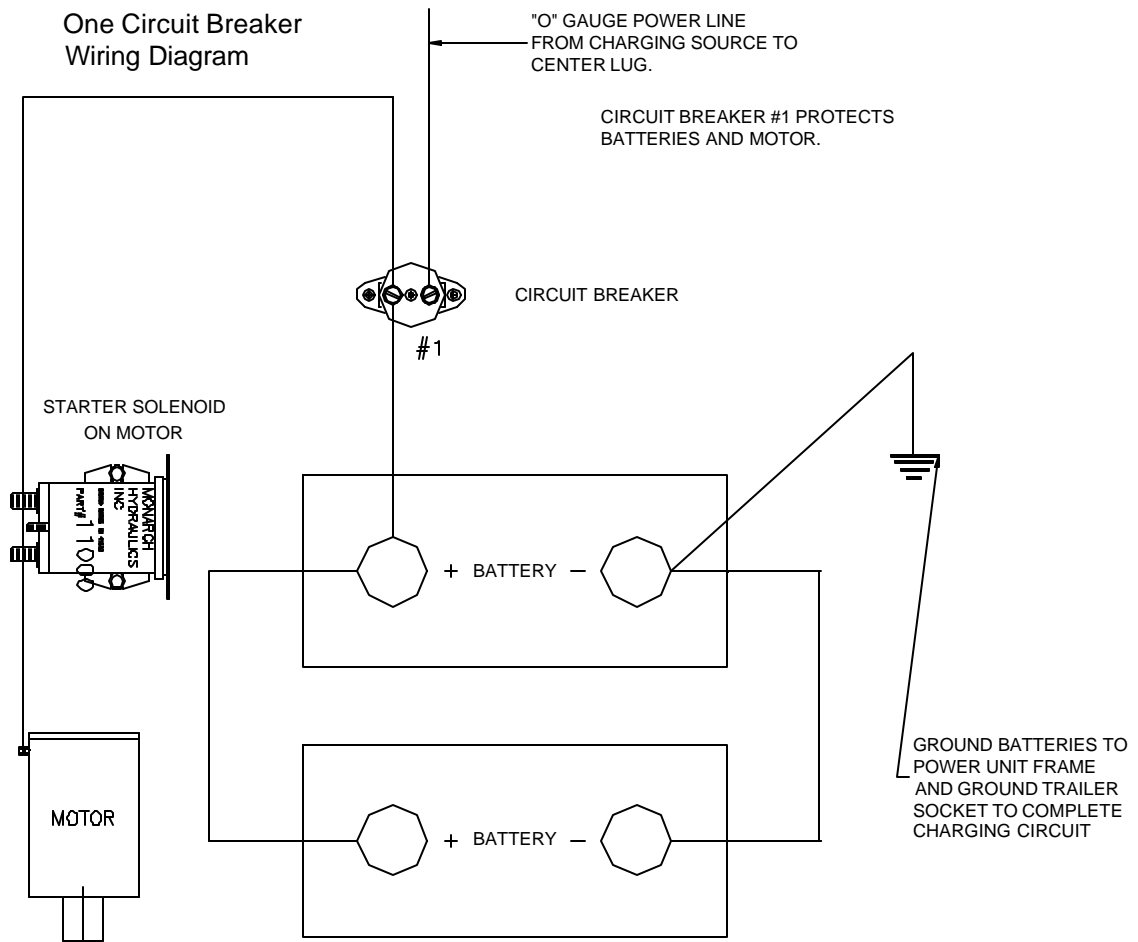

## FAILURE TO USE CORRECT BATTERIES WILL VOID WARRANTY

Place rubber pads under each battery to prevent movement, and securely tighten Battery Clamp.

# GROUNDING RECOMMENDATIONS FOR TRACTOR/ TRAILER

---

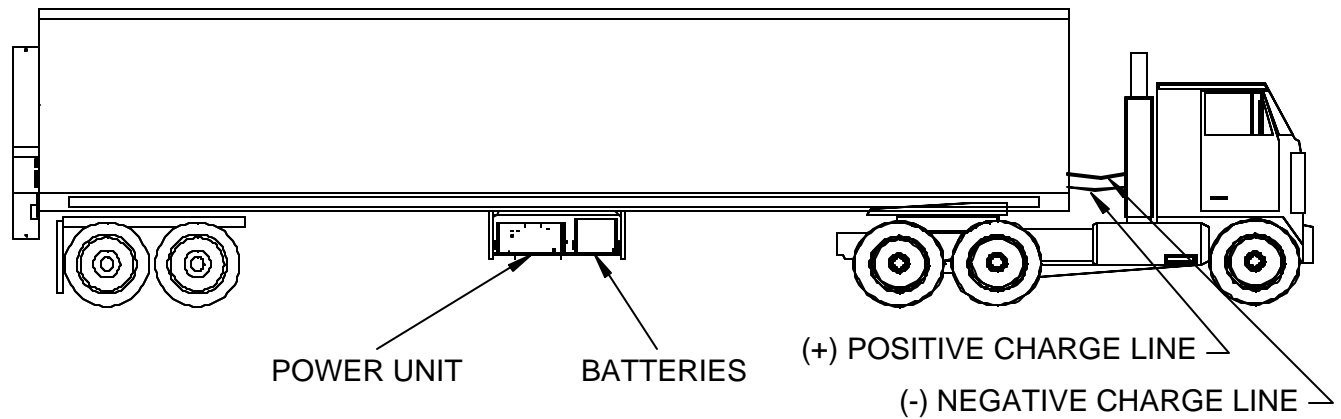

The MAINTENANCE MINDER 2<sup>®</sup> controller requires that a minimum of 8 volts be maintained under load in order for the FXD<sup>®</sup> power unit to operate. Utilization of a single positive cable does not provide sufficient ground. Therefore, our recommendation for grounding tractor/trailers with a FXD<sup>®</sup> gate is as follows:

Two (2) cables: one (1) positive and one (1) negative, both running to the tractor batteries.

## NOTE:

The use of a battery charger as the sole power source to operate a FXD<sup>®</sup> is unauthorized and will prevent the FXD<sup>®</sup> from working properly. The lift gate must always be operated in conjunction with at least one (1) 12-volt dual purpose heavy-duty lift gate battery. A minimum of 10.5 volts must be maintained in order for the valves to operate.

# MAINTENANCE MINDER 2<sup>®</sup> OVERVIEW

---

Power unit is equipped with the Maintenance Minder 2<sup>®</sup> Controller. It will:

- Automatically keep track of maintenance intervals and warn the user when maintenance is due, based on the number of lifts.
- Record low voltage occurrences.
- Record of high temperature faults.
- Record of maximum run time faults, when a single operation exceeded the maximum continuous run time limit.
- Give helpful trouble-shooting information on MENU 4, “Last Lift Info”.

## FAULTS CODES

A decal in the power unit enclosure lists the following signal codes for these faults:

1 BEEP	Service Fault (reached the number of lifts when maintenance is due)
2 BEEPS	Low Voltage Fault (check battery condition and power line connections)
3 BEEPS	Max. Time Fault (exceeded the maximum continuous run time allowed)
4 BEEPS	High Temperature Fault (unit will not run until motor cools)

All faults signals will be repeated FOUR times, except the Service Fault signal. Controller will prevent power unit from operating during the time period when a fault signal is sounding (about 5 to 10 sec.) except for the Service Fault signal. The controller is also equipped with an anti-doorbelling feature, which prevents rapid ON/OFF operation of the power unit.

## RESETTING after MAINTENANCE IS PERFORMED

To RESET the Maintenance Minder 2<sup>®</sup> after maintenance has been performed:

1. Go to MENU 2, hit “ENTER”, and toggle down to the “Reset All Info” screen.
2. Press and hold the hidden RESET button under Maintenance Minder 2<sup>®</sup> logo at top of faceplate.
3. Follow the instructions on the screen regarding a second button, which must be pressed to complete the reset operation.



# MAINTENANCE MINDER 2<sup>®</sup> CONTROLLER MENUS

---

**(Press MENU)**

MENU 1 – LIFT GATE INFO

**(Press ENTER, then ARROW DOWN for each item)**

Model Number, Serial Number, Manufacture Date, Vehicle ID, Hardware Version, Firmware Version, Software Version.



**(Press MENU and ARROW DOWN once)**

MENU 2 – PERIOD INFO (data for current maintenance period)

**(Press ENTER, then ARROW DOWN for each item)**

**Number of Lifts** (gives the number during this maintenance interval and the set number when maintenance is due)

**Motor ON** (total motor run time in minutes for this maintenance period)

**Service Fault** (number of times gate was operated PAST the maintenance limit)

**Max. Time Faults** (times motor exceeded its maximum allowable continuous run time)

**High Temperature Faults** (times thermal switch in motor tripped, if switch is provided)

**Low Voltage Faults** (times low voltage occurred)

**Reset all Info** (Reset data after performing maintenance, once maintenance limit is reached – see reset instructions on previous page)



# MAINTENANCE MINDER 2<sup>®</sup> CONTROLLER MENUS

---

(Press **MENU** and **ARROW DOWN** twice)

MENU 3 – LIFE TIME INFO (data for the total life time of the gate)

(Press **ENTER**, then **ARROW DOWN** for each item)

Same items will appear as under PERIOD INFO, except this is LIFE TIME data.

**Reset History** (reviews history for each maintenance interval)

Press **ENTER**, then **ARROW DOWN** to show history. Most recent period is the highest #. Screen shows Period #, # of Lifts, and Total Run Time in minutes.



(Press **MENU** and **ARROW DOWN** three times)

MENU 4 – LAST LIFT INFO (Trouble Shooting Screen – it records data that occurred during the last lift made)

(Press **ENTER**, then **ARROW DOWN** for each item)

**Supply Voltage** (first voltage is the minimum voltage that occurred during the last lift – if below 6 volts gate will stop / second voltage is the supply voltage just before gate operation, must be at least 10 volts).

**Motor ON** (motor run time in seconds during last lift, gate will stop at 180 seconds).

**Window Time** (time in milliseconds during the last lift that the voltage dropped in between 6 and 8 volts – must not be any longer than 3 seconds or gate will stop).



## NOTE:

Controller has an anti-doorbelling feature. Motor will not operate if UP switch is toggled rapidly. This prevents welding of the start solenoid contacts.

# BLEEDING THE LIFT CYLINDERS - GRAVITY DOWN

---

The FXD<sup>®</sup> is shipped with the cylinders pre-filled with hydraulic fluid from the factory. *The cylinders must be bled before making any other adjustments.*

## To Bleed the Lifting Cylinder – Bottom Side:

1. Unfold and lower the platform to the full down position. **CYLINDERS SHOULD BE EXTENDED TO THEIR FULL LENGTH (GATE EXTENDED DOWN 56”) TO REMOVE AS MUCH AIR FROM THE BOTTOM SIDE OF THE CYLINDER AS POSSIBLE. DEPENDING ON THE FLOOR HEIGHT OF THE VEHICLE, IT MAY BE NECESSARY TO RAISE THE BODY OF THE VEHICLE OR LOWER THE GATE PLATFORM INTO A PIT TO ACHIEVE MAXIMUM CYLINDER EXTENSION.**
2. Loosen the plugs in the back ports (ports closest to the vehicle body), but do not remove completely.
3. Activate the pump just long enough to produce an air-free stream of oil from the ports.
4. Re-tighten the plugs in the ports, lower the platform to the full down position, and check the oil level in the reservoir tank. The oil level should be approximately 2” from top of the tank for DUAL power units.

## To Bleed the Lifting Cylinders – Top Side

1. Not applicable on gravity down.

**NOTE: FOR GRAVITY DOWN GATES, OIL LEVEL SHOULD ALWAYS BE CHECKED WITH THE PLATFORM UNFOLDED AND ALL THE WAY DOWN.**

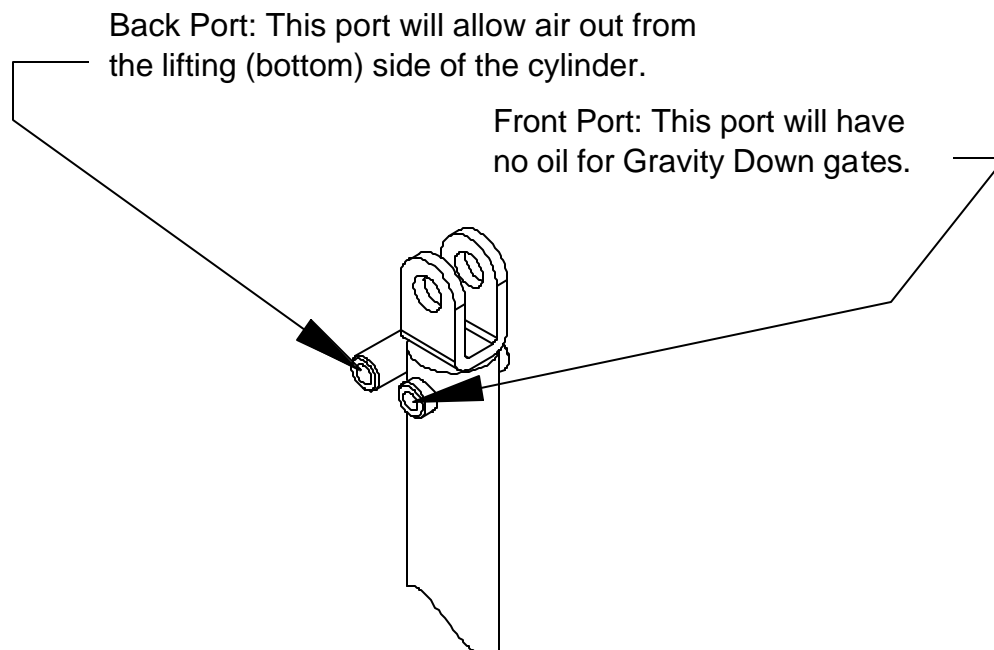

# BLEEDING THE LIFT CYLINDERS – POWER DOWN

---

The FXD<sup>®</sup> is shipped with the cylinders pre-filled with hydraulic fluid from the factory. *The cylinders must be bled before making any other adjustments.*

## **To Bleed the Lifting Cylinder – Bottom Side:**

1. Unfold and lower the platform to the full down position. **CYLINDERS SHOULD BE EXTENDED TO THEIR FULL LENGTH (GATE EXTENDED DOWN 56”) TO REMOVE AS MUCH AIR FROM THE BOTTOM SIDE OF THE CYLINDER AS POSSIBLE. DEPENDING ON THE FLOOR HEIGHT OF THE VEHICLE, IT MAY BE NECESSARY TO RAISE THE BODY OF THE VEHICLE OR LOWER THE GATE PLATFORM INTO A PIT TO ACHIEVE MAXIMUM CYLINDER EXTENSION.**
2. Loosen the plugs in the back ports (ports closest to the vehicle body), but do not remove completely.
3. Activate the pump just long enough to produce an air-free stream of oil from the ports.
4. Re-tighten the plugs in the ports, raise the platform to the full up position, and check the oil level in the reservoir tank. The oil level should be approximately 2” from top of the tank for DUAL power units.

## **To Bleed the Lifting Cylinders – Top Side**

1. Unfold and raise the platform to the full up position to remove as much air from the top side of the cylinder as possible.
2. Loosen the plugs in the front ports (ports furthest from the vehicle body) but do not remove completely.
3. Activate the pump (DOWN) just long enough to produce an air-free stream of oil from the ports.
4. Retighten the plugs in the ports, raise the platform to the full up position if not already there, and check the oil level in the reservoir tank. The oil level should be approximately 2” from top of the tank for DUAL power units.

**NOTE: FOR POWER DOWN GATES, OIL LEVEL SHOULD ALWAYS BE CHECKED WITH THE PLATFORM UNFOLDED AND RAISED ALL THE WAY UP.**

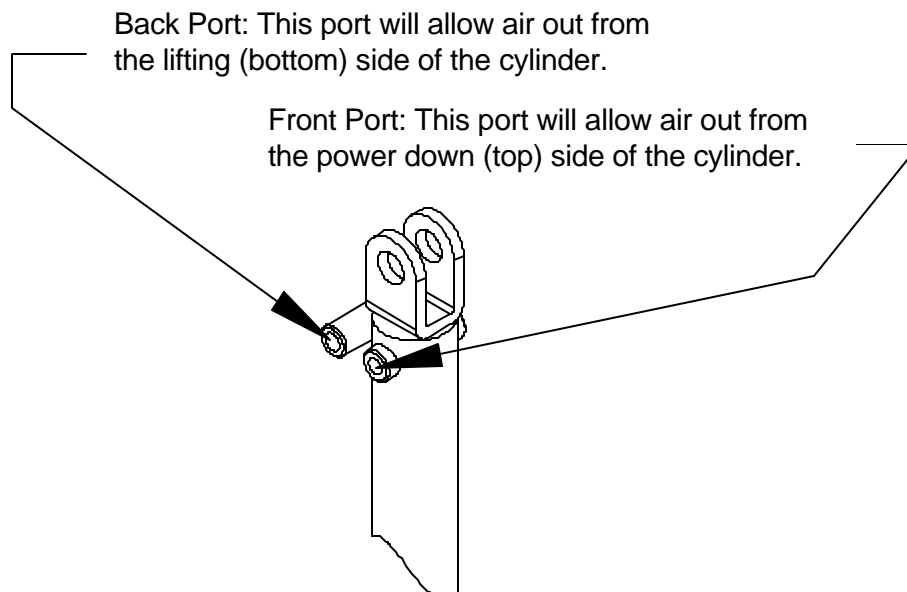

# TO BLEED THE POWER FOLD CYLINDER

---

1. Unfold and lower the platform down to the ground.
2. Loosen the hose at the cylinder but do not remove completely.
3. Activate the pump just long enough to product an air free stream of oil from the hose.
4. Re-tighten the hose and check the oil level in the reservoir tank. Note: hold line while tightening to ensure it does not twist.
5. Fold and unfold the platform several times. The platform should now fold and unfold smoothly.

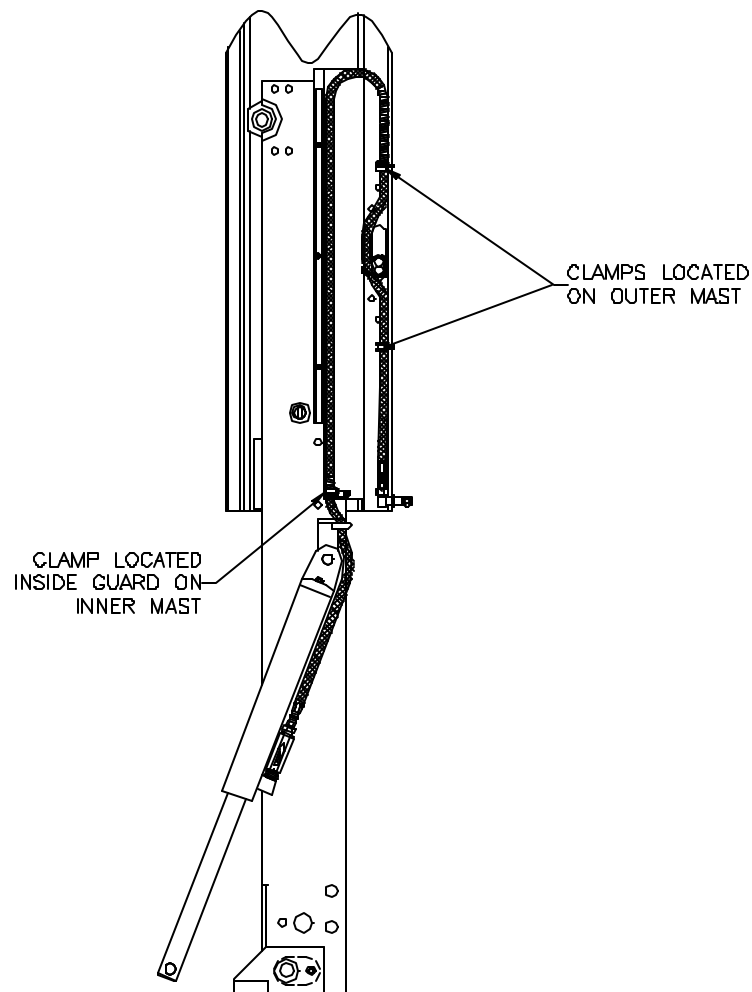

## **CHECK OIL LEVEL AFTER BLEEDING THE CYLINDER:**

GRAVITY DOWN GATES – Check with platform unfolded and on ground.

POWER DOWN GATES – Check with platform unfolded and up at bed height.

# ADJUSTMENT OF THE EQUALIZER VALVE

---

## NOTE:

Before making any adjustments, read the General Trouble Shooting Tips page to be sure this is the problem. **Do NOT adjust Equalizer Valve in an attempt to compensate for a bent Tie Bar, bad roller, or other mechanical issue.**

Remember adjusting the equalizer valve will control the **up** stroke only.

Locate the equalizer valve. Equalizer valve is mounted on power unit frame, behind the power unit box.

Back off the lock nut on the side that is running slow (lagging) turn the adjusting screw out  $\frac{1}{4}$  turn, lock nut and try. Repeat if necessary.

Although this can be done with no load on the platform, it normally helps to have a light load on the platform.

## NOTE:

Turn the adjusting screw in = decreases the flow of oil

Turn the adjusting screw out = increases the flow of oil

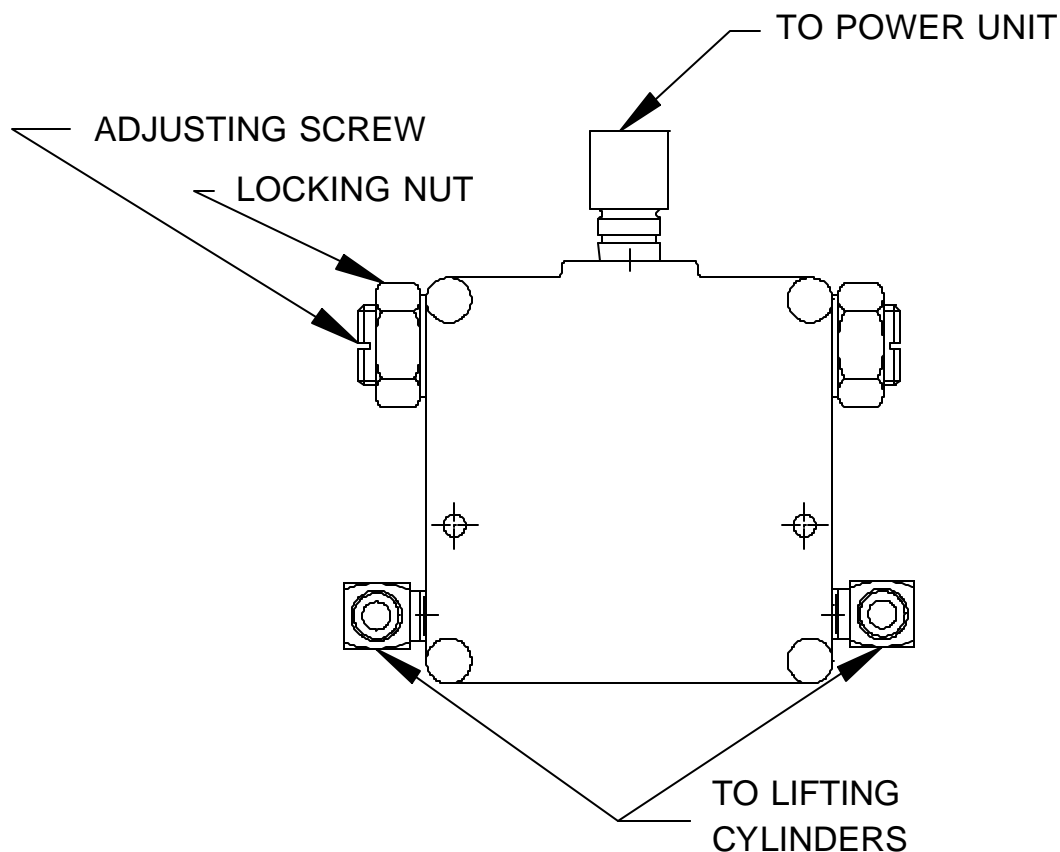

# STRAIGHTENING THE TIE BAR

---

**NOTE:**

Before bending the tie bar, read the general tips page to be sure this is the problem.

To check that you have a bent tie bar, raise the platform to the full *up* position (level to the floor). Push the down switch, one side will always drop quicker than the other side. If one side is lower by more than one inch (1"), adjust the tie bar.

The tie bar is at the back edge of the platform. It is 1 ½" wide, and holds the two inner masts together.

Acquire a piece of wood 4" x 4" x 2' long and place the wood between the tie bar and the up stop area near the floor line area. **Caution!** Check for cracked welds before proceeding. **Stand clear while performing this procedure.**

**NOTE:**

If the curbside is dropping first, place the wood on the driver's side. Run the gate up until the wood is secure, keep running the gate up another 6 to 8 inches. Let the gate down, remove the wood, cycle the lift gate to see if this has fixed the problem. If not, re-bend, except go up another inch or two. Keep repeating until corrected.

Sometimes, the power from the gate is not enough to correct the problem. If you have a hand pump, use it to take it up further. If you do not have a hand pump, use a floor jack and continue jacking the gate in an upward cycle.

**PICTURE SHOWS HOW TO STRAIGHTEN A BENT TIE BAR ON CURBSIDE.  
(CURB SIDE DROPS QUICKER)**

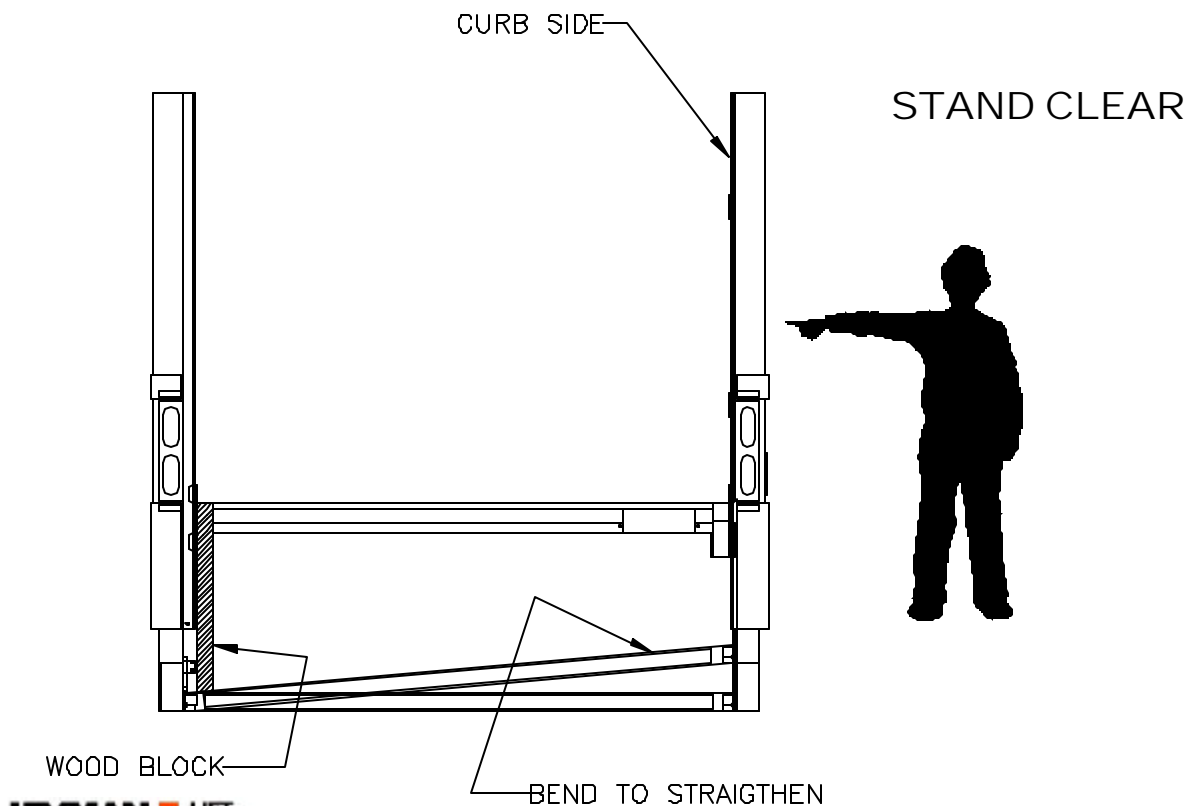

# HYDRAULIC PARTS REPLACEMENT

Index No.	Qty Req'd	Part Number	Part Name	Remarks
1	2	P34101	Hyd. Cylinder	<b>SEE NEXT PAGE</b>
2	1	AT-501-354-081	Hydraulic Line Assy.	LH Lifting
3	1	See Chart	Hydraulic Line Assy.	LH "Down" Line
4	1	See Chart	Hydraulic Line Assy.	RH Lifting
5	1	See Chart	Hydraulic Line Assy.	RH "Down" Line
6	2	P34102	Velocity Fuse 4.5 GPM	<b>SEE NEXT PAGE</b>
7	4	P34103	Long Nipple	
8	4	P34015	Elbow	
9	1	P34145	Bulkhead Tee	
10	1	AT-501-354-027	Hydraulic Line Assy.	
11	3	P34106	Bulkhead Elbow	
12	3	P46497	3/4" Split Loom	72" or 24" Lg ea.
13	4	P34058	Adapter	
14	1	P34051	Elbow	

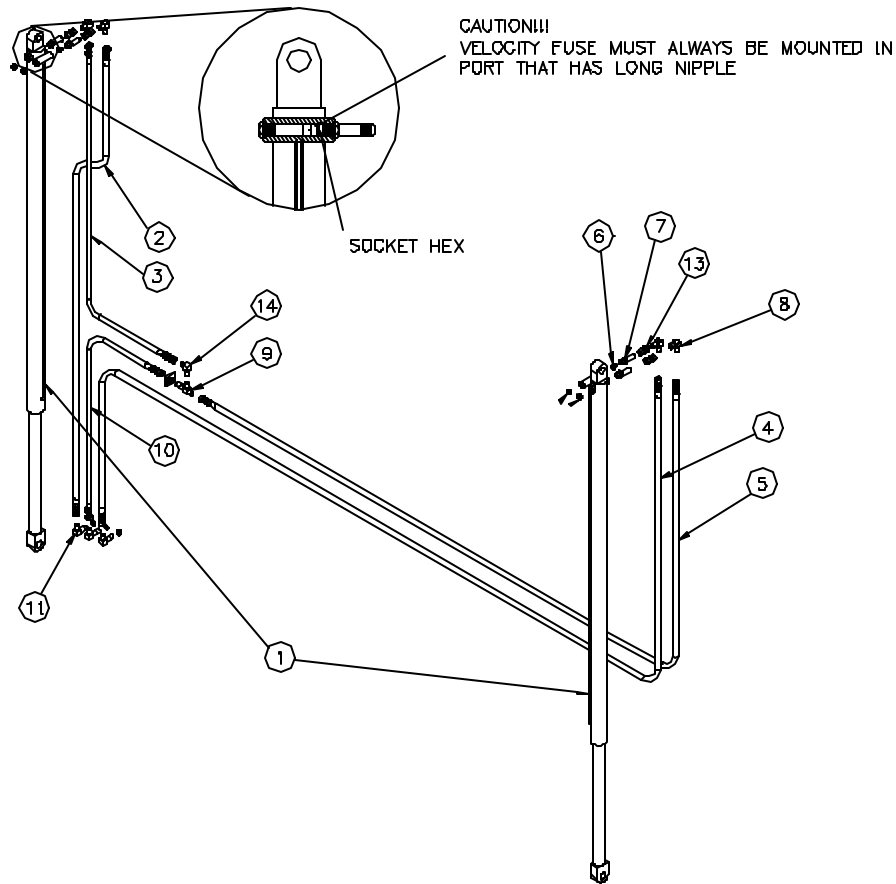

Drawing No.	Gate Width	Qty Req'd	LH "Down" Item 3	RH Lifting Item 4	RH "Down" Item 5
CA-820-100	102"	1 ea.	AT-501-354-074	AT-501-354-174	AT-501-365-012
CA-820-125	96"	1 ea.	AT-501-354-077	AT-501-365-014	AT-501-365-011

# HYDRAULIC PARTS REPLACEMENT (Cont.)

WARNING! VELOCITY FUSE (HOSE BURST VALVE) MUST BE MOVED FROM OLD TO NEW CYLINDER, WHEN REPLACING LIFT CYLINDER. FAILURE TO FOLLOW THESE INSTRUCTIONS COULD RESULT IN INJURY.

## REPLACING LIFT CYLINDER P34101 ON FXD / FDC-CR RAIL GATE

CAUTION!!  
VELOCITY FUSE MUST ALWAYS BE MOUNTED IN PORT THAT HAS LONG NIPPLE. REMOVE VELOCITY FUSE FROM OLD CYLINDER AND PLACE IN NEW.

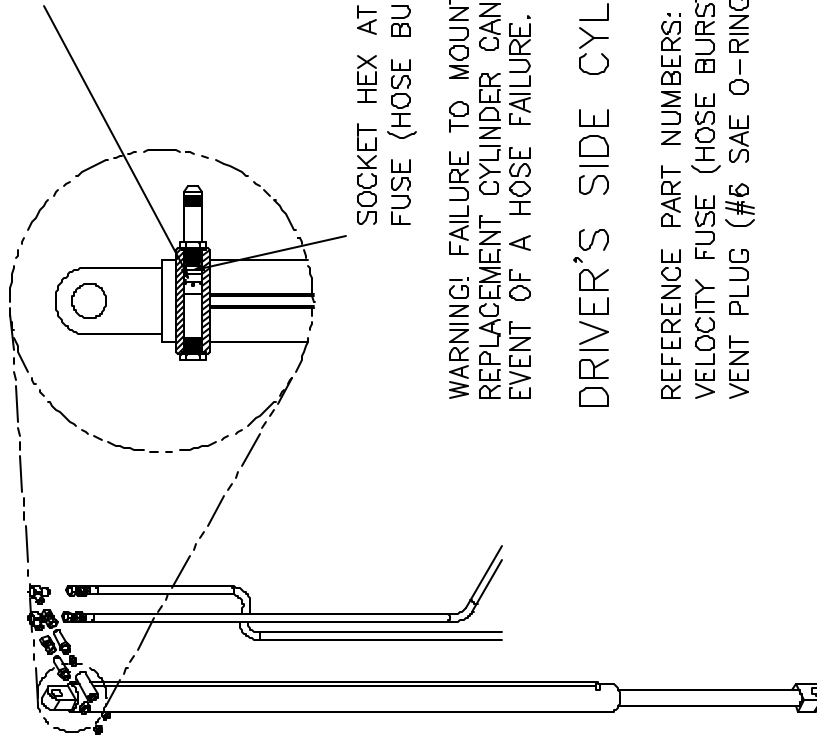

SOCKET HEX AT TOP OF VELOCITY FUSE (HOSE BURST VALVE).

WARNING! FAILURE TO MOUNT VELOCITY FUSE IN REPLACEMENT CYLINDER CAN CAUSE INJURY, IN THE EVENT OF A HOSE FAILURE.

DRIVER'S SIDE CYLINDER SHOWN

REFERENCE PART NUMBERS:  
VELOCITY FUSE (HOSE BURST VALVE) P34102  
VENT PLUG (#6 SAE O-RING) P34107

CA820100MAN

# POWER FOLD PARTS REPLACEMENT

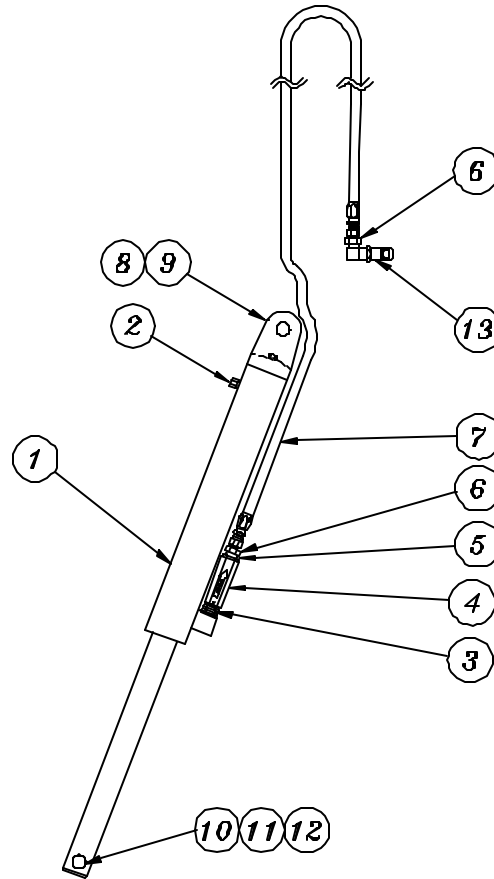

Index No.	Qty Req'd	Part Number	Part Name
1	1	P34108	Hyd. Cylinder
2	1	P33646	Breather Vent – 3/8 NPT
3	1	P34050	Straight Nipple
4	1	P34179	Flow Control Valve – STEEL PLATFORM
4	1	P34159	Flow Control Valve – ALUM. PLATFORM
5	1	P34044	Straight Nipple
6	2	P34110	Adapter
7	1	AT-501-410-079	Hose Assembly (with Spring Guard)
8	1	AP-820-097	Top Ram Pin
9	2	P24019	Retaining Ring
10	1	S754-005.500	Bottom Ram Mtg Pin – STEEL PLATFORM
10	1	AP-451-945	Bottom Ram Mtg Pin – ALUM. PLATFORM
11	1	P47532	Roll Pin – STEEL PLATFORM
11	1	P47538	Roll Pin – ALUM. PLATFORM
12	2	P26019	Washer
13	1	P34106	Bulkhead Elbow

# REPLACEMENT ROLLER

---

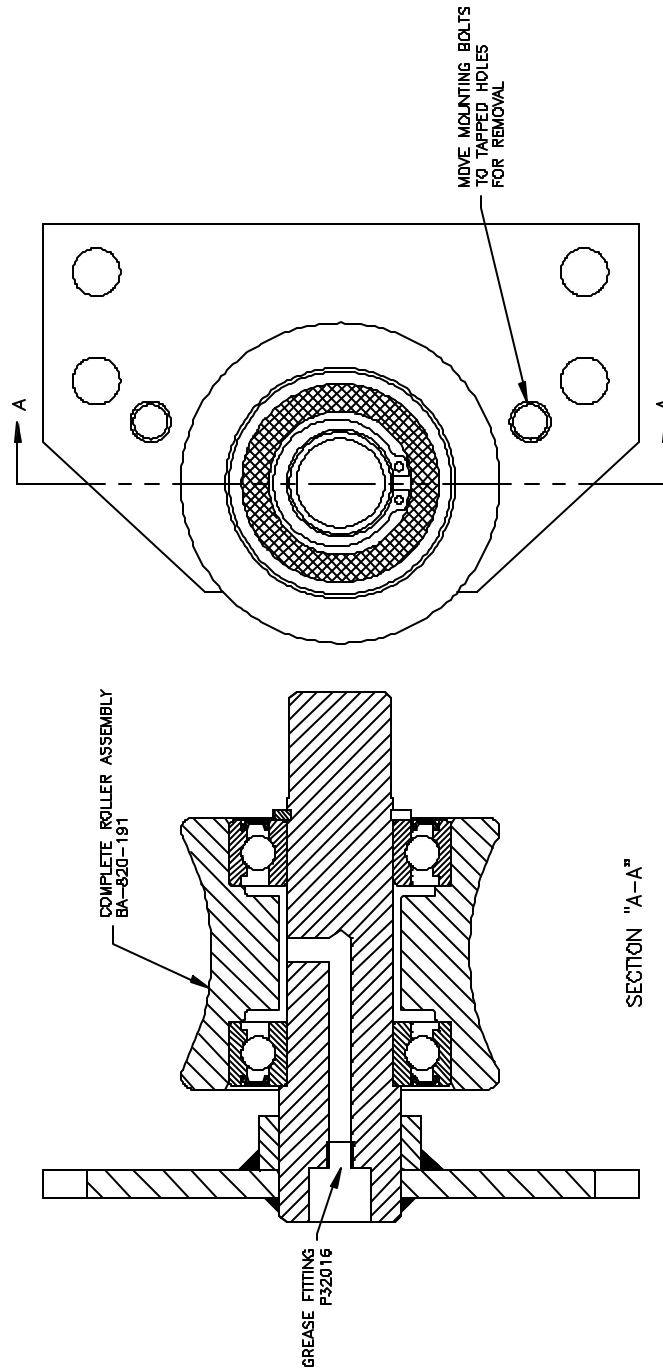

**REPLACEMENT ROLLER IS ONLY SOLD AS A COMPLETE ASSEMBLY UNDER PART NO. BA-820-191. SPECIAL EQUIPMENT IS REQUIRED TO MOUNT BEARINGS ON ROLLER AND SHAFT TO AVOID BEARING DAMAGE. THIS CAN ONLY BE PROPERLY DONE AT OUR FACTORY.**

# PLATFORM PINS AND BUSHINGS

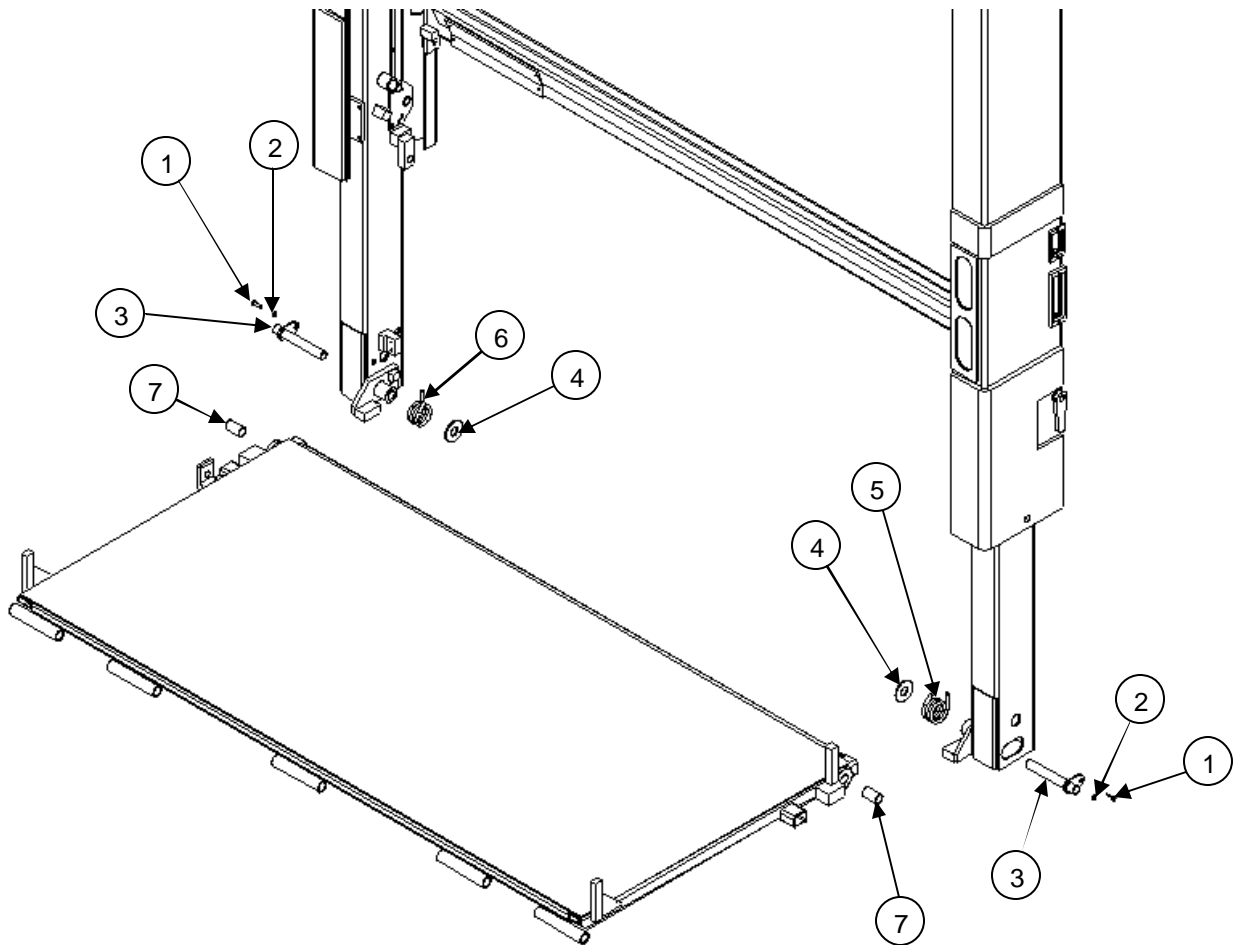

Index No.	Qty.	Part Number	Part Name	Material Size/Notes
1	2	P11021	Bolt	3/8-16 x 1 G5
2	2	P26017	Washer Lock Split 3/8	3/8
3	2	BA-820-264	Shaft Assembly	
4	6	P26521	Spacer Washer	1"
5	1	P25217	Torsion Spring RH	
6	1	P25218	Torsion Spring LH	
7	2	P43578	Platform Bearing	

# INNER MAST WEAR PAD ADJUSTMENT

---

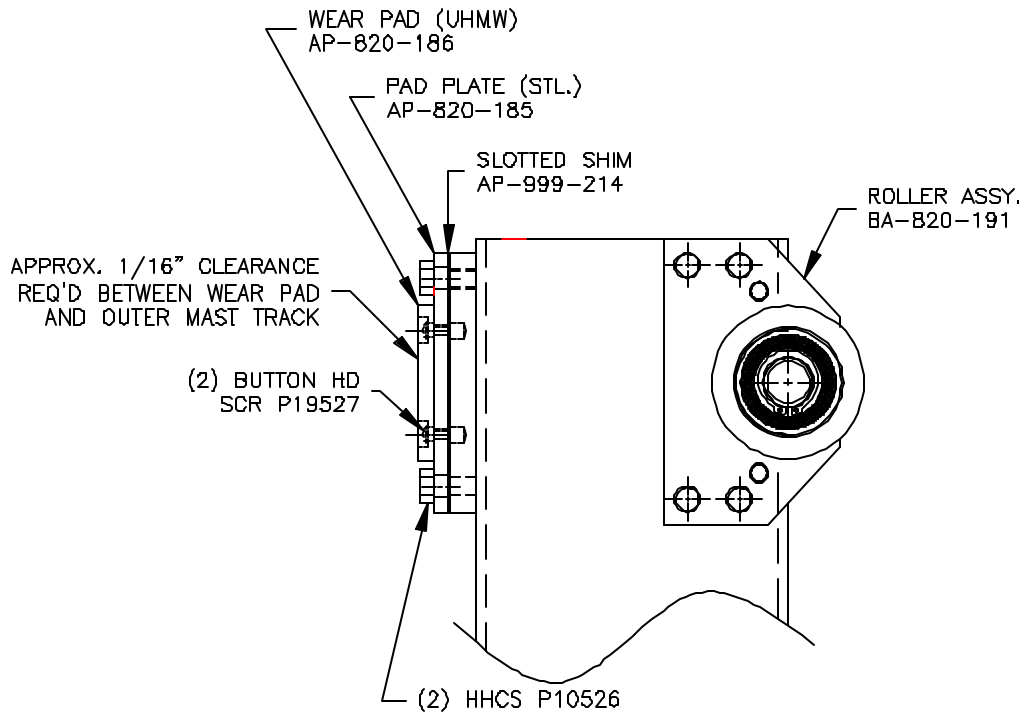

CHECK WEAR PAD CLEARANCE WITH PLATFORM UNFOLDED. RUN PLATFORM UP AND DOWN TO SEAT ROLLERS. CHECK CLEARANCE WITH GATE POSITIONED AT DIFFERENT VERTICAL LOCATIONS.

# INNER MAST FOLD STOP ADJUSTMENT

---

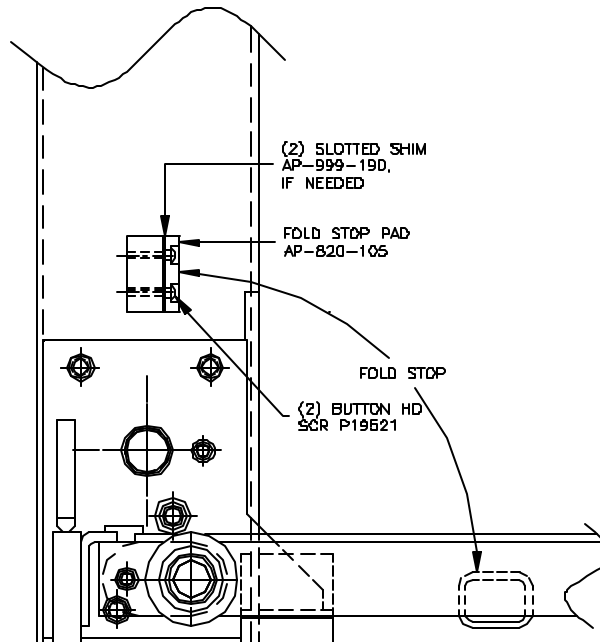

# SWITCH WIRING GRAVITY DOWN

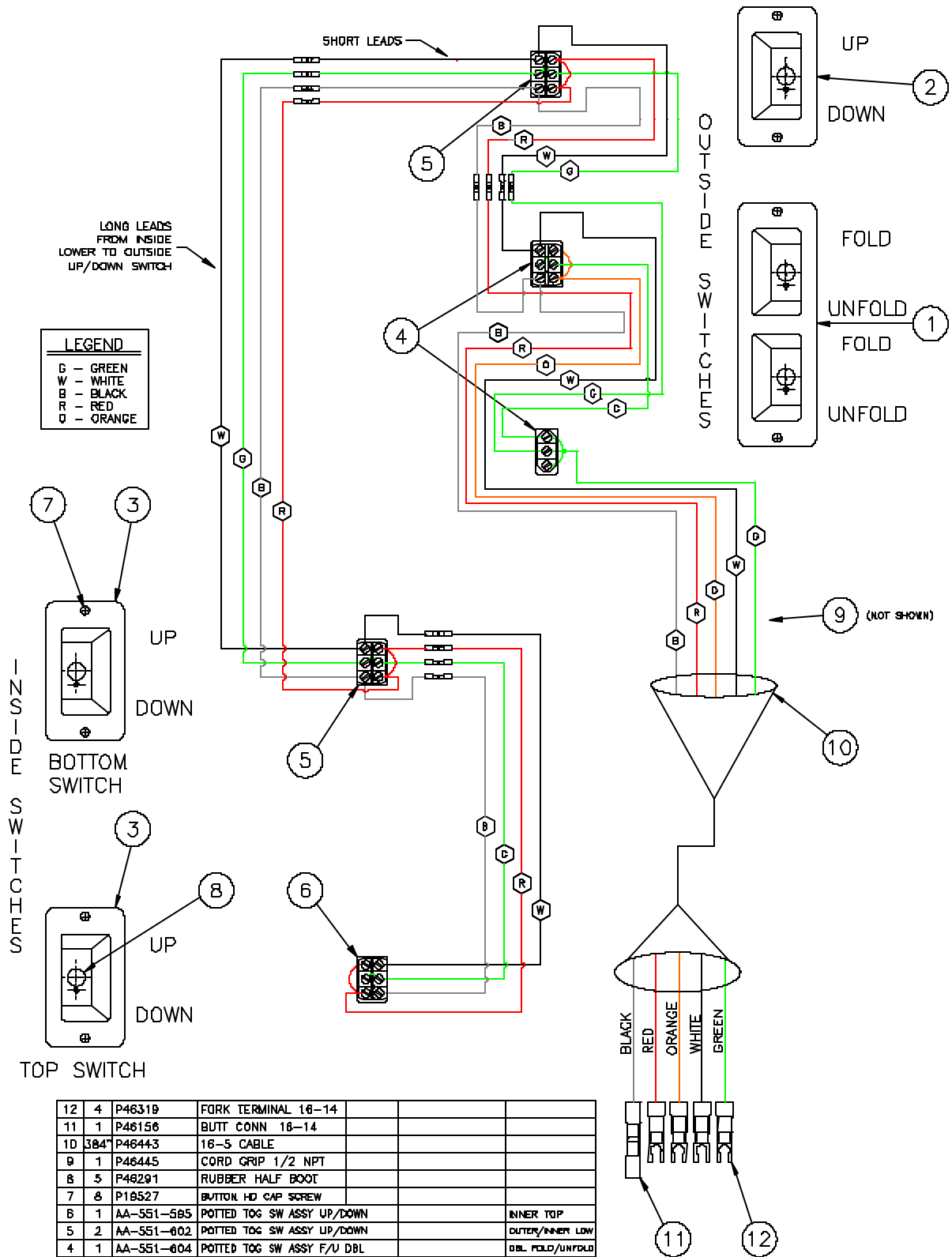

12	4	P4631B	FORK TERMINAL 16-14			
11	1	P46156	BUTT CONN 16-14			
10	384	P46443	16-5 CABLE			
9	1	P46445	CORD GRIP 1/2 NPT			
8	5	P48291	RUBBER HALF BOOT			
7	8	P19527	BUTTON HD CAP SCREW			
6	1	AA-551-565	POTTED TOG SW ASSY UP/DOWN			INNER TOP
5	2	AA-551-602	POTTED TOG SW ASSY UP/DOWN			OUTER/INNER LOW
4	1	AA-551-604	POTTED TOG SW ASSY F/U DBL			DBL FOLD/UNFOLD
3	2	BP-820-133	REC SW PLATE - SINGLE/INNER			UP / DOWN
2	1	BP-820-198	REC SW PLATE - SINGLE/OUTER			UP / DOWN
1	1	BP-820-134	RECESSED SW PLATE-DBL			FOLD / UNFOLD
INDEX NO.	QTY	PART NO.	PART NAME	MATL.	MATERIAL SIZE	REMARKS

# SWITCH WIRING POWER DOWN

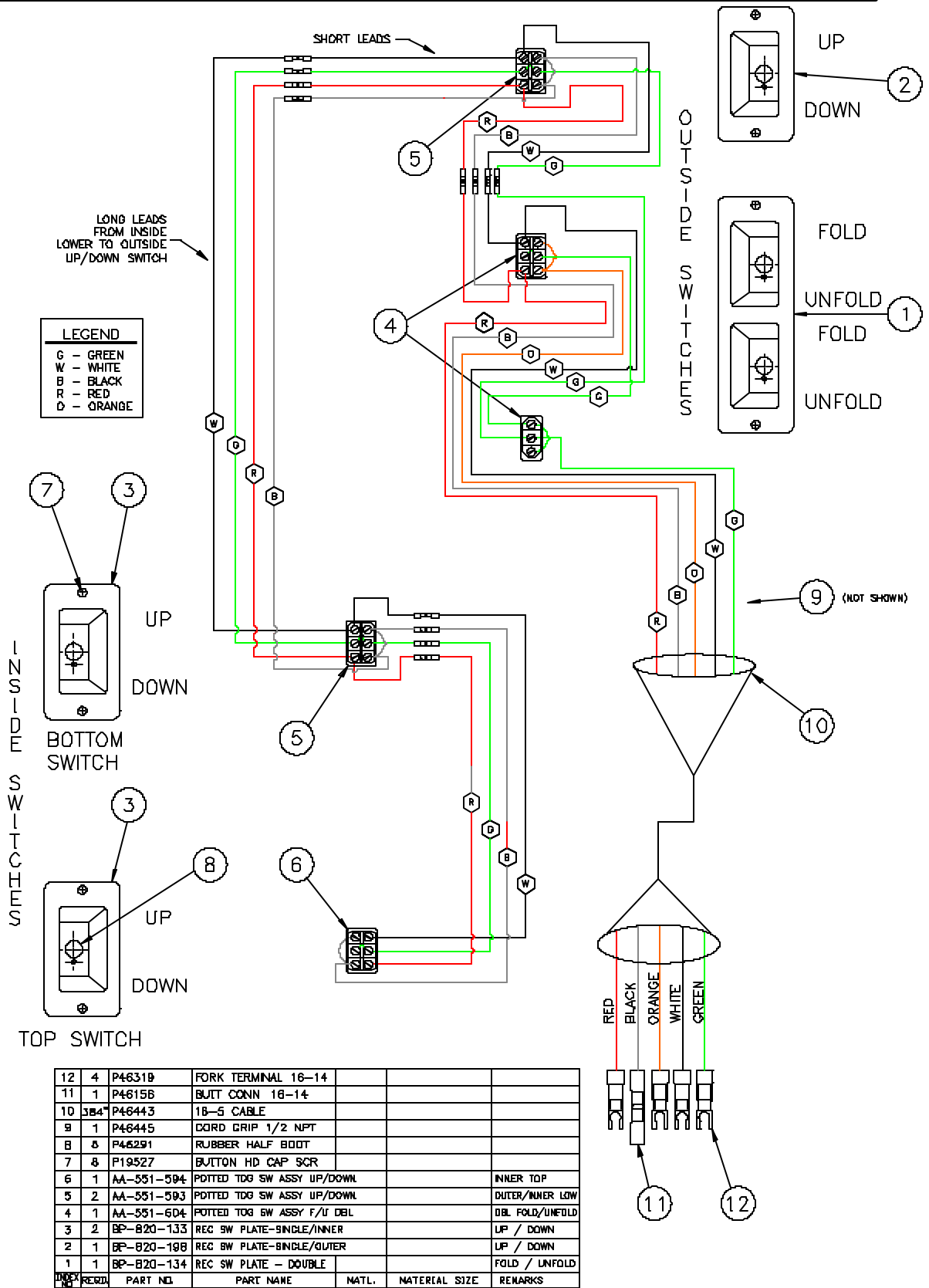

# EMERGENCY WALK AROUND GRAV. DOWN

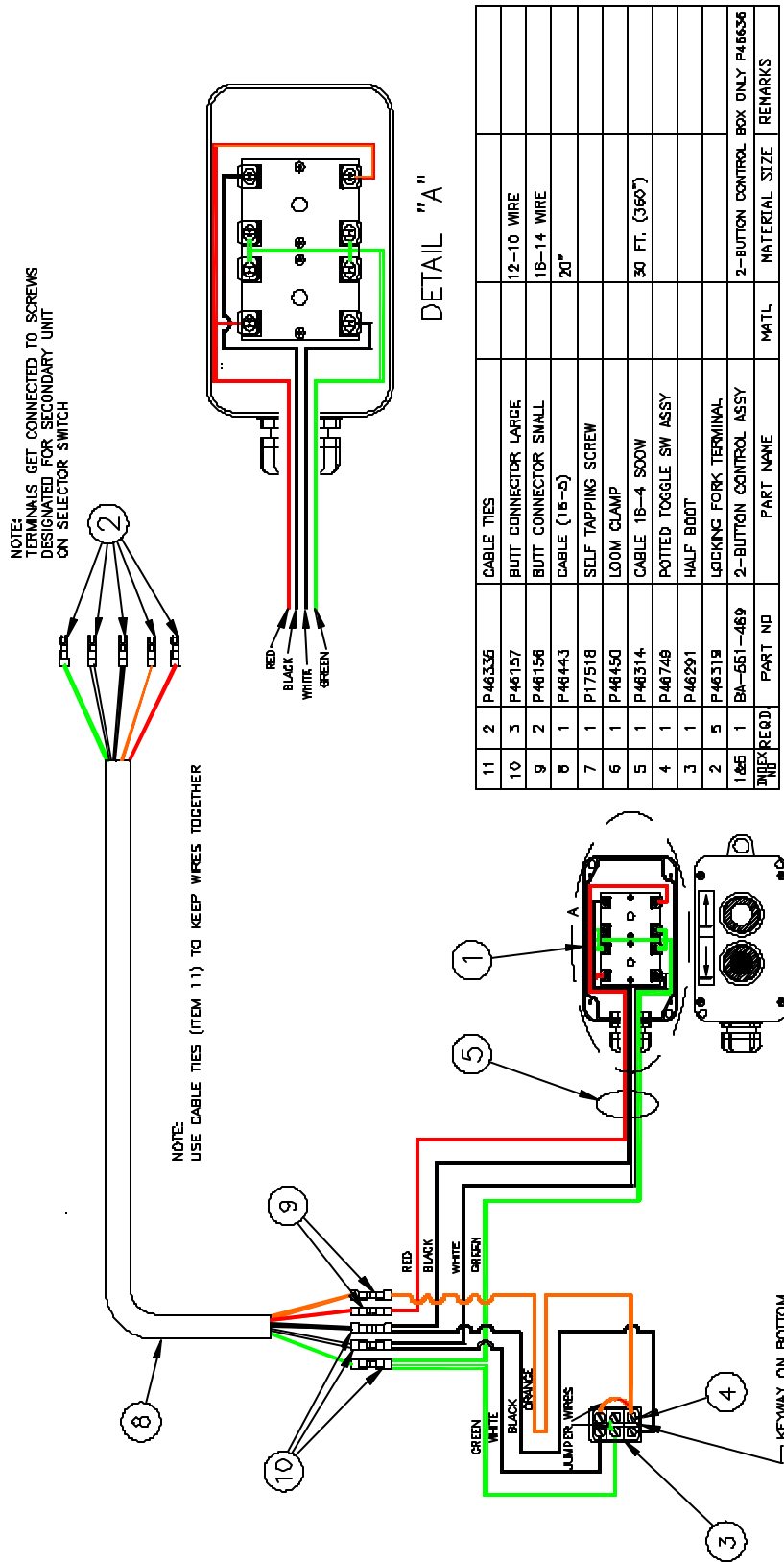

REPLACEMENT 2-BUTTON CONTROL BOX ALONE IS P46636

# EMERGENCY WALK AROUND POWER DOWN

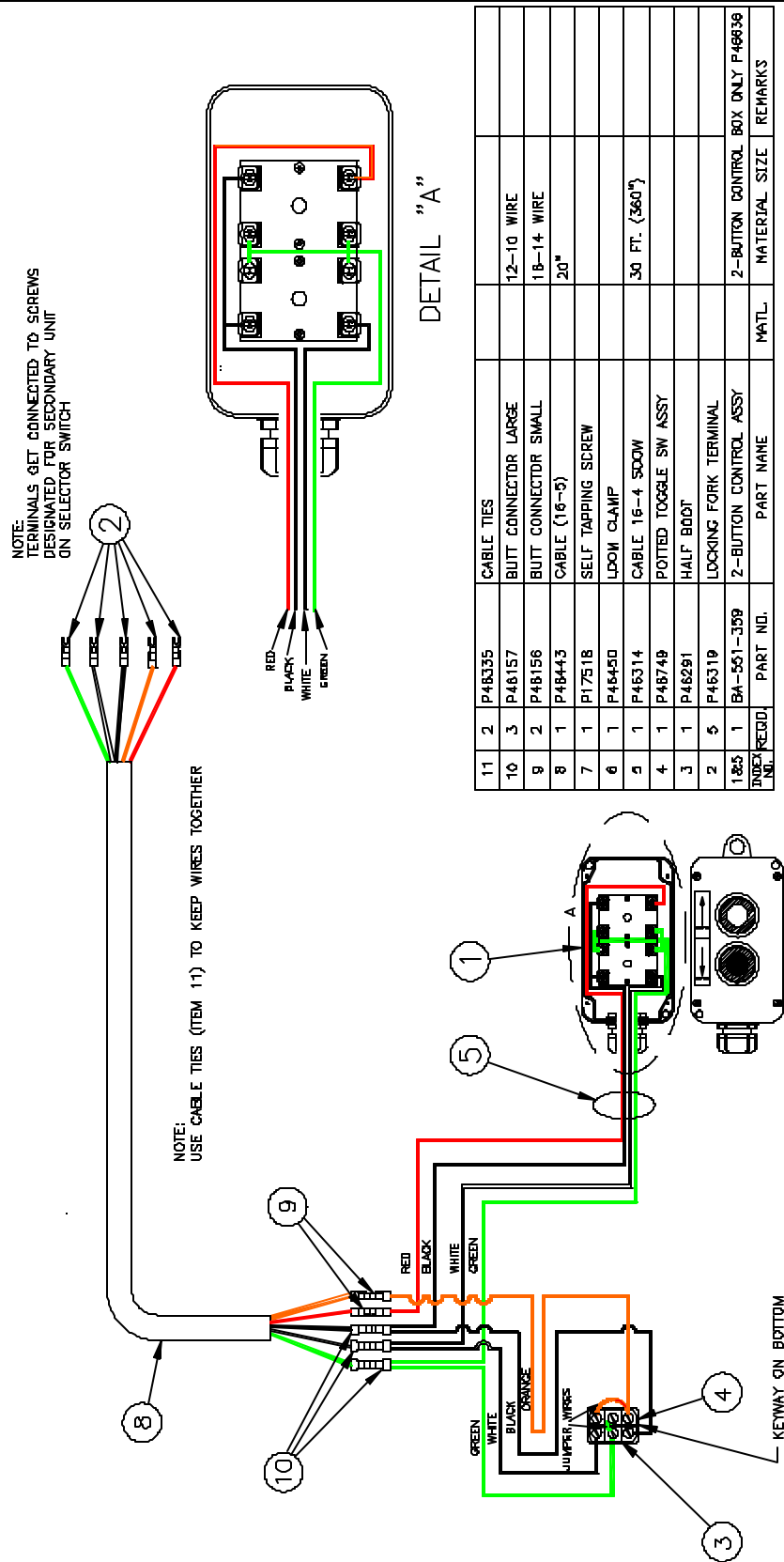

REPLACEMENT 2-BUTTON CONTROL BOX ALONE IS P46636

# POWER UNIT PARTS – GRAVITY DOWN

**COMPLETE GRAVITY DOWN POWER UNIT P34117  
PRIMARY AND SECONDARY POWER UNITS ARE THE SAME**

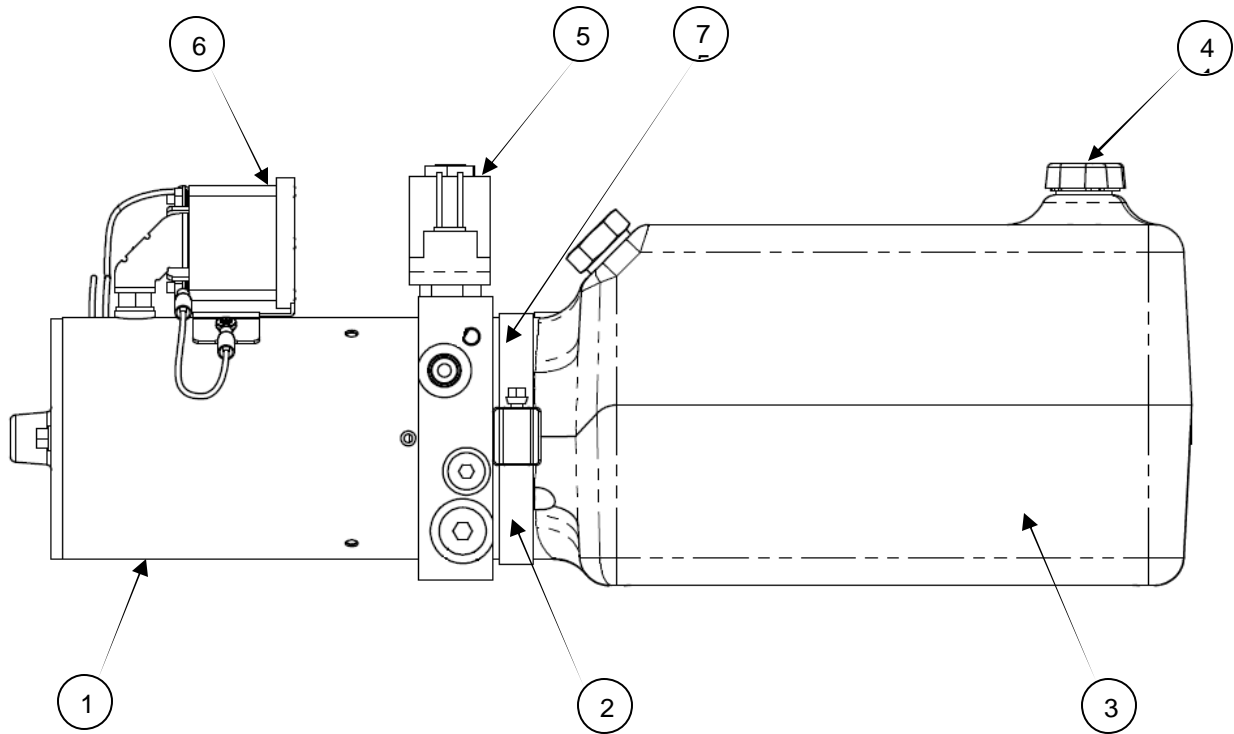

Index No.	Qty.	Part Number	Part Name
1	1	P34027A	Motor
2	1	P34056	Pump
3	1	P34152	Tank
4	1	LH150015	Breather Cap
5	1	P34154	"A" Valve Assembly
6	1	P34016	Start Solenoid
7	1	P34099	Tank O-ring

## POWER UNIT PARTS – GRAV. DOWN (Cont.)

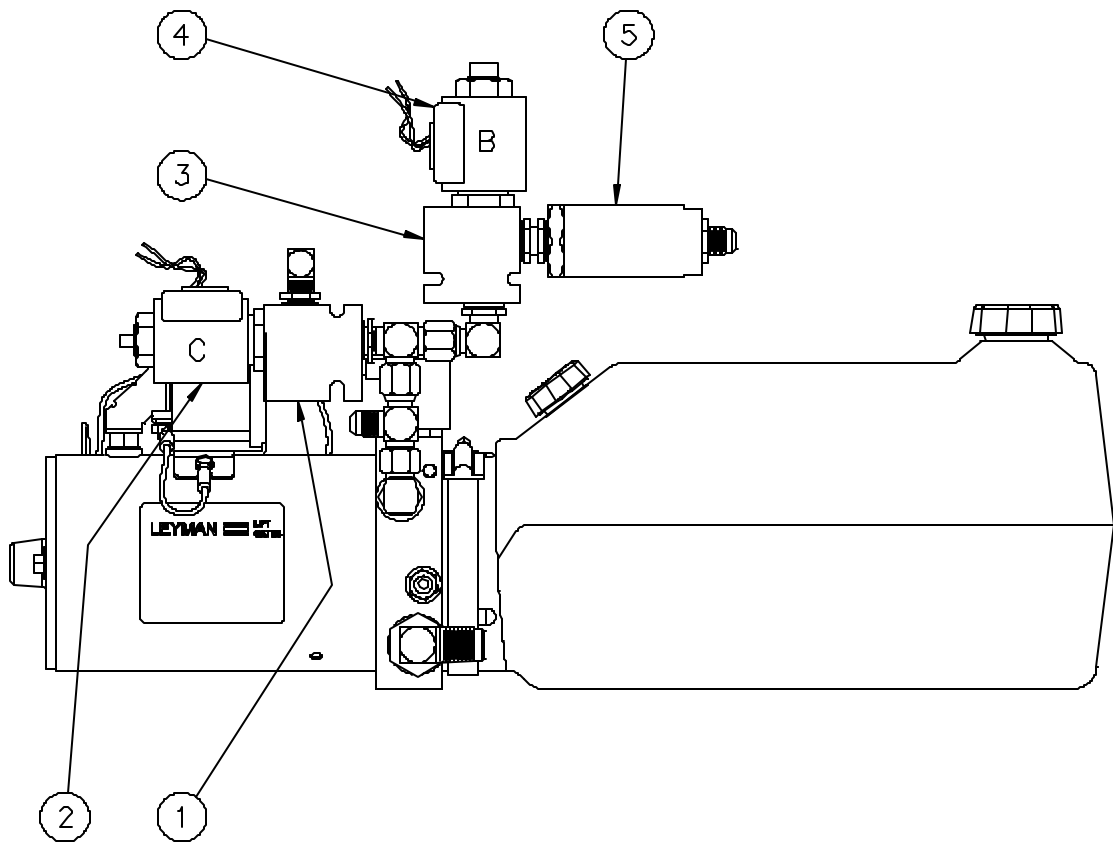

"B" & "C" VALVES ON PRIMARY POWER UNIT

Index No.	Qty.	Part Number	Part Name
1	1	P34047	Valve Block #8 Cav.
2	1	P34131	"C" Valve Stem & Coil
3	1	P34133	Valve Block #10 Cav.
4	1	P34132	"B" Valve Stem & Coil
5	1	P34046	Filter

# POWER UNIT PARTS – POWER DOWN

## COMPLETE POWER DOWN POWER UNIT P34118B PRIMARY AND SECONDARY POWER UNITS ARE THE SAME

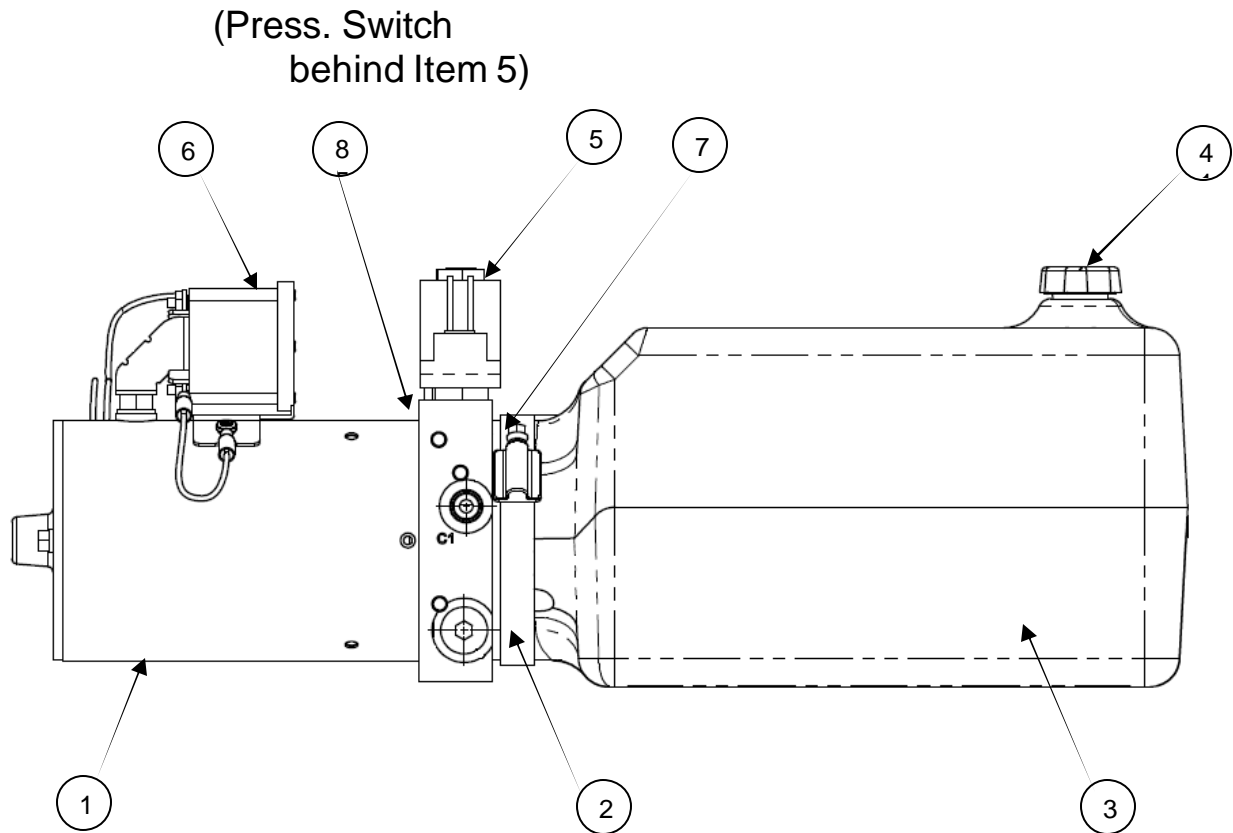

Index No.	Qty.	Part Number	Part Name
1	1	P34027A	Motor
2	1	P34056	Pump
3	1	P34153	Tank
4	1	LH150015	Breather Cap
5	1	P34155	"A" Valve Assembly
6	1	P34016	Start Solenoid
7	1	P34099	Tank O-ring
8	1	P46693	Pressure Switch

# POWER UNIT PARTS – POWER DOWN (Cont.)

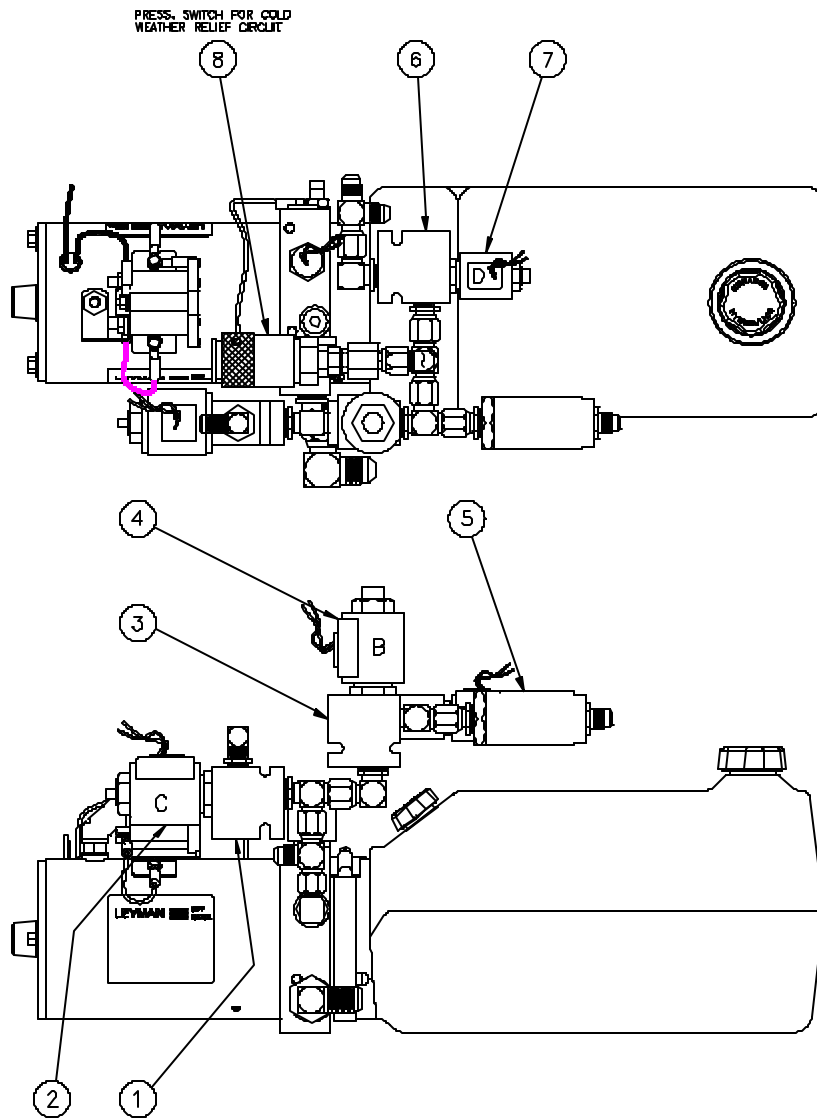

"B", "C", & "D" VALVES ON PRIMARY POWER UNIT

Index No.	Qty.	Part Number	Part Name
1	1	P34047	Valve Block #8 Cav.
2	1	P34131	"C" Valve Stem & Coil
3	1	P34133	Valve Block #10 Cav.
4	1	P34132	"B" Valve Stem & Coil
5	1	P34046	Filter
6	1	P34047	Valve Block #8 Cav.
7	1	P34091	"D" Valve Stem & Coil
8	1	P46612	Press. Sw. (CWRV)

# DIVIDER VALVE / FLOW CONTROLS - GRAV. DOWN

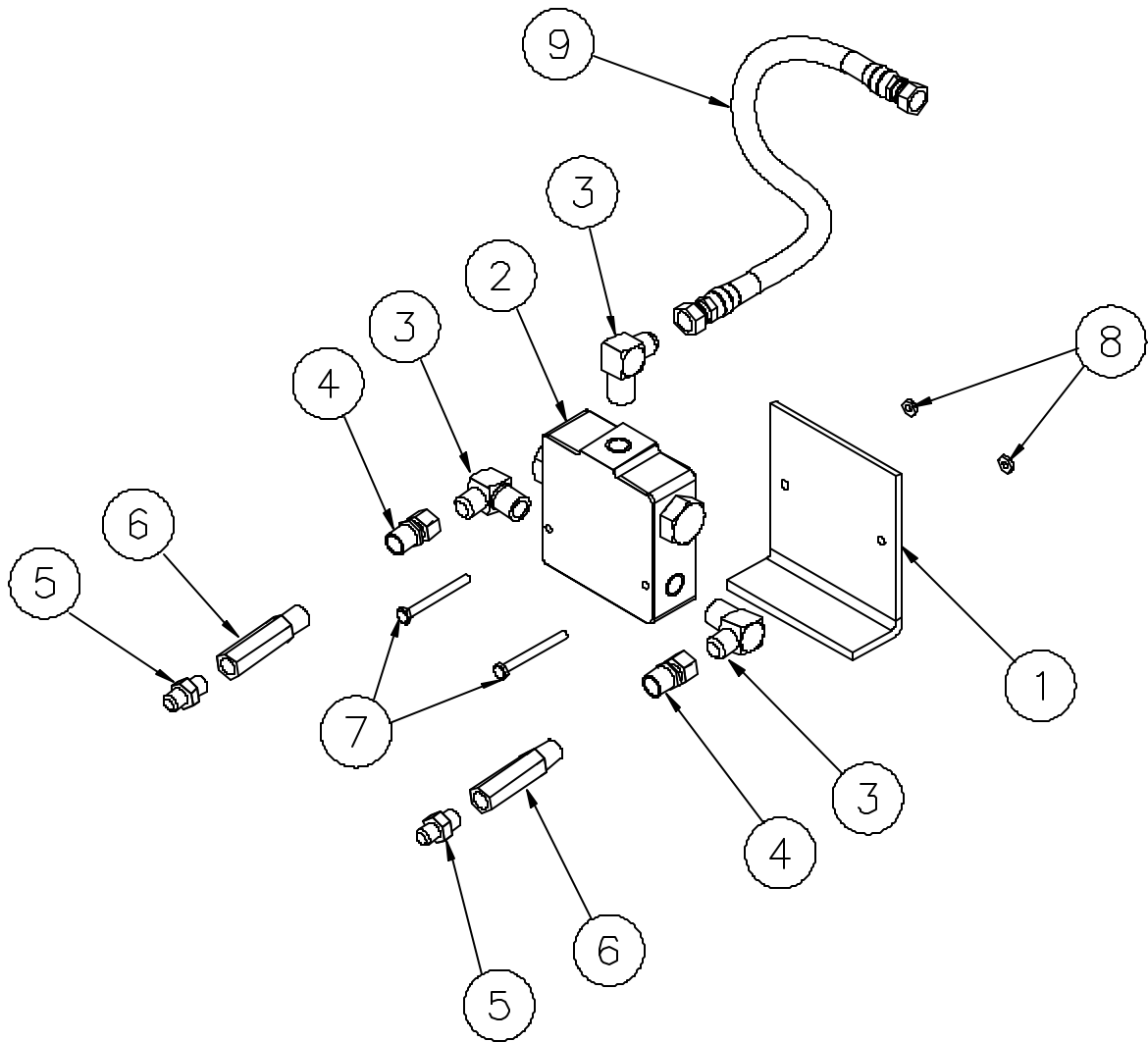

Index No.	Qty.	Part Number	Part Name
1	1	AP-811-718	Div. Valve Mtg. Brkt.
2	1	P33547H	Divider Valve
3	3	P34128	Elbow
4	2	P34042	Straight Adapter
5	2	P34044	Straight Adapter
6	2	P34159	2.8 Flow Control Valve (matched set)
7	2	P10508	Bolt (1/4-20)
8	2	P23502	Lock Nut
9	1	AT-501-354-013	Hose Assembly

# DIVIDER VALVE / FLOW CONTROLS - PWR. DOWN

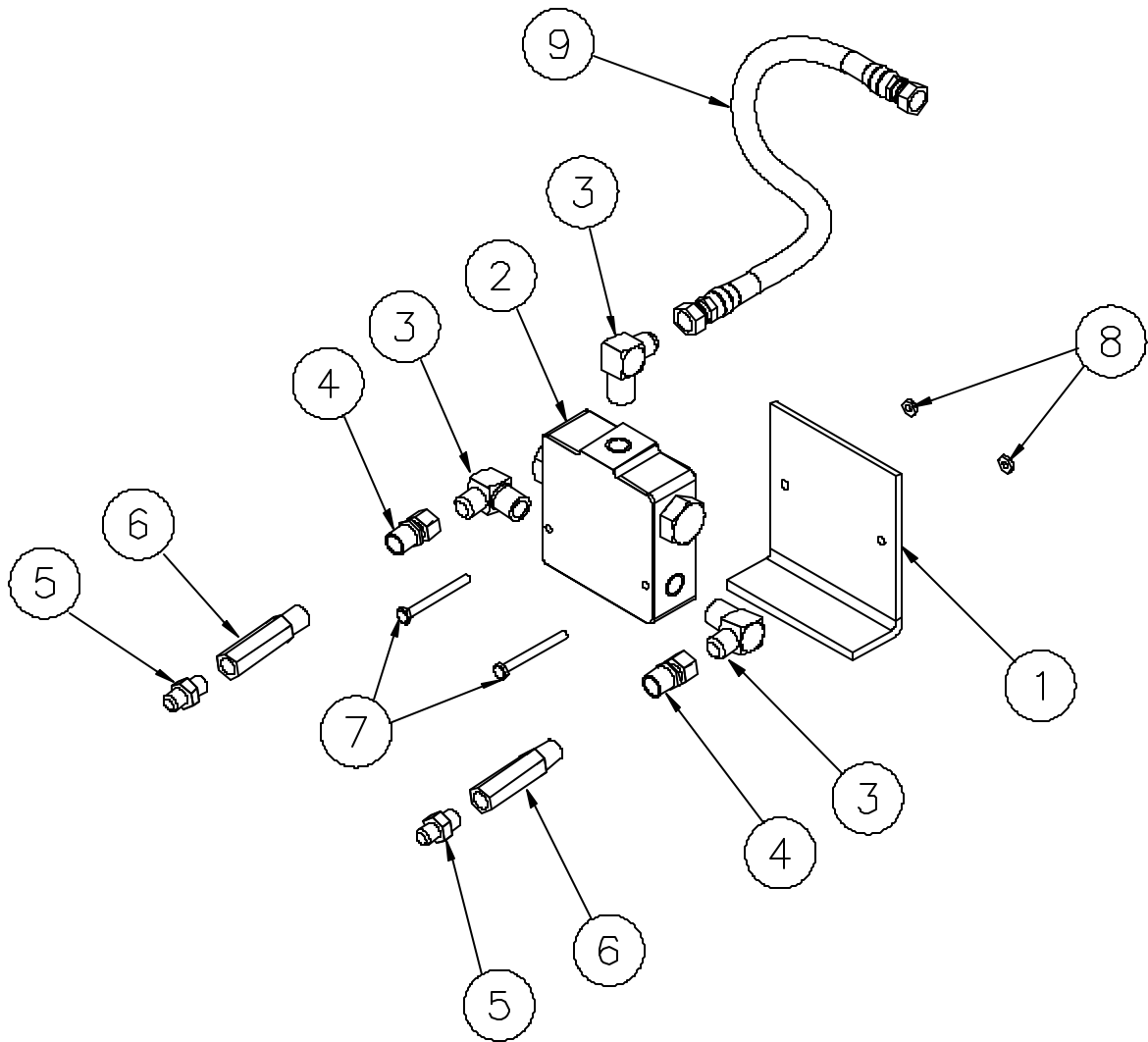

Index No.	Qty.	Part Number	Part Name
1	1	AP-811-718	Div. Valve Mtg. Brkt.
2	1	P33547H	Divider Valve
3	3	P34128	Elbow
4	2	P34042	Straight Adapter
5	2	P34044	Straight Adapter
6	2	P34161	2.0 Flow Control Valve (matched set)
7	2	P10508	Bolt (1/4-20)
8	2	P23502	Lock Nut
9	1	AT-501-354-013	Hose Assembly

# SAFETY WARNING SIGNS / DECALS

---

## STREET SIDE DECALS

Warning Signs and Decals will be replaced at any time  
FREE OF CHARGE

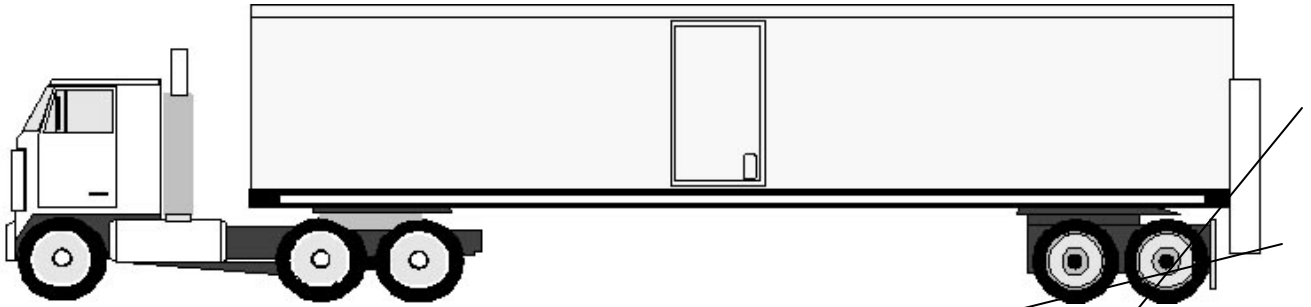

P55295

Will receive two of these decals. One goes on each side at bottom of Outer Mast



P55309

# SAFETY WARNING SIGNS / DECALS

## CURB SIDE DECALS

Warning Signs and Decals will be replaced at any time  
FREE OF CHARGE

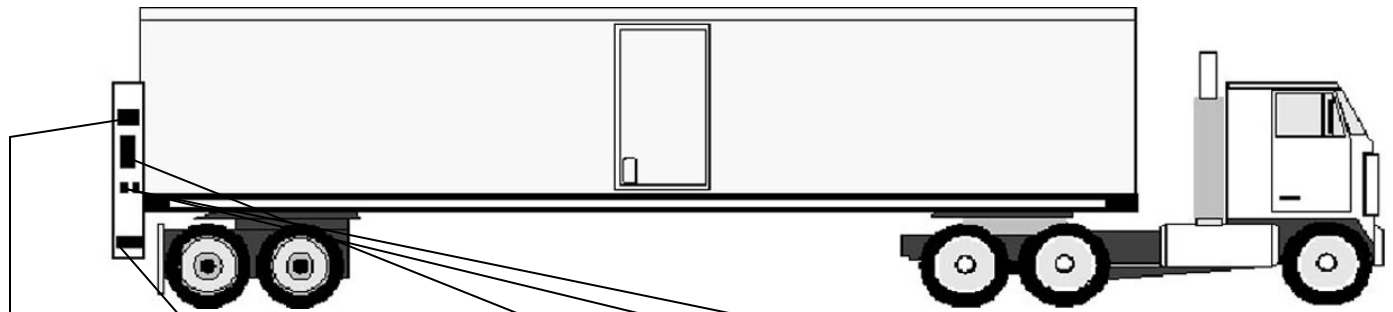

P55295



P55433

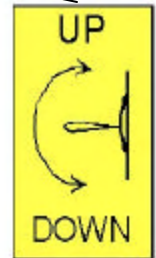
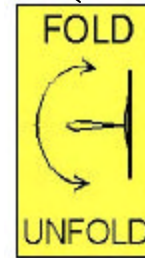

Mount each decal next to the corresponding toggle switch. Make sure you mount three UP / DOWN decals (two on the inside of the Outer Mast). Mount two FOLD / UNFOLD decals (next to the dual switch plate).

Mount one Max. Cap. decal on outside of Outer Mast near switches. Mount other Max. Cap. decal on Inner Mast just above chain anchor.

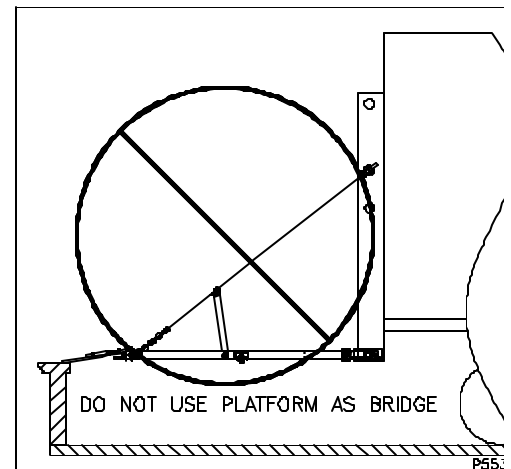
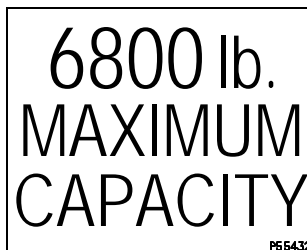

# SAFETY WARNING SIGNS / DECALS

## REAR OF VEHICLE DECALS

Warning Signs and Decals will be replaced at any time  
FREE OF CHARGE



P55296

Will receive two of these decals  
One goes on each side of the Outer Mast

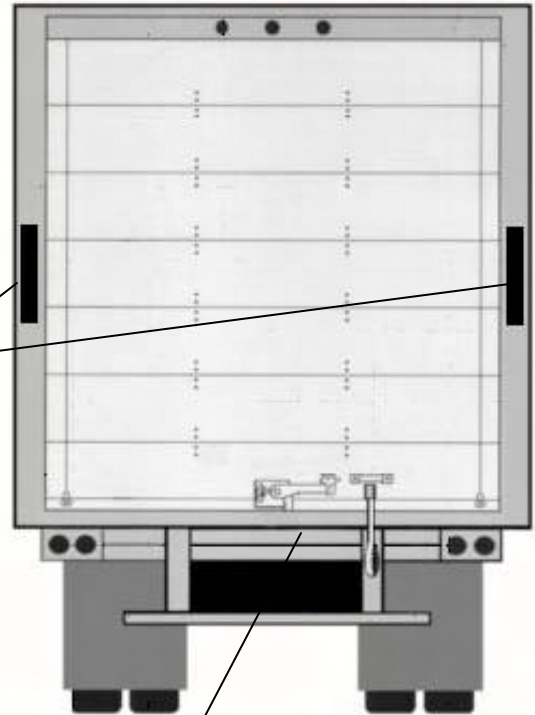

P55138

**CAUTION KEEP FEET FROM EDGE OF PLATFORM**

Decal Part Numbers not listed on diagrams:

(2) 6800 MAX CAP P55432

(3) FOLD / UNFOLD

P55185

(3) UP / DOWN P55221

(1) URGENT WARNING

P55157

(1) DO NOT USE AS BRIDGE P55363

# MODEL AND SERIAL NUMBER TAGS

---

Serial No. is also located in MENU 1 of Maintenance Minder 2®

Serial number tag is located inside power unit box.

	
10900 KENWOOD ROAD CINCINNATI, OHIO 45242 513-891-6210 WWW.LEYMANLIFT.COM	
MODEL	FXD68PDD-8684RR
SERIAL NO.	289999
CAPACITY	6800 lbs.
MANUFACTURE DATE	08-14-08

Model number tag is located on the left-hand Outer Mast.

	
10900 KENWOOD ROAD CINCINNATI, OHIO 45242 513-891-6210 WWW.LEYMANLIFT.COM	
MODEL	FXD68PDD-8684RR
CAPACITY	6800 lbs.
MANUFACTURE DATE	08-14-08
PATENTS PENDING	

