



Installation Manual

FXD68

Fold-A-Vador®

Rail Gate

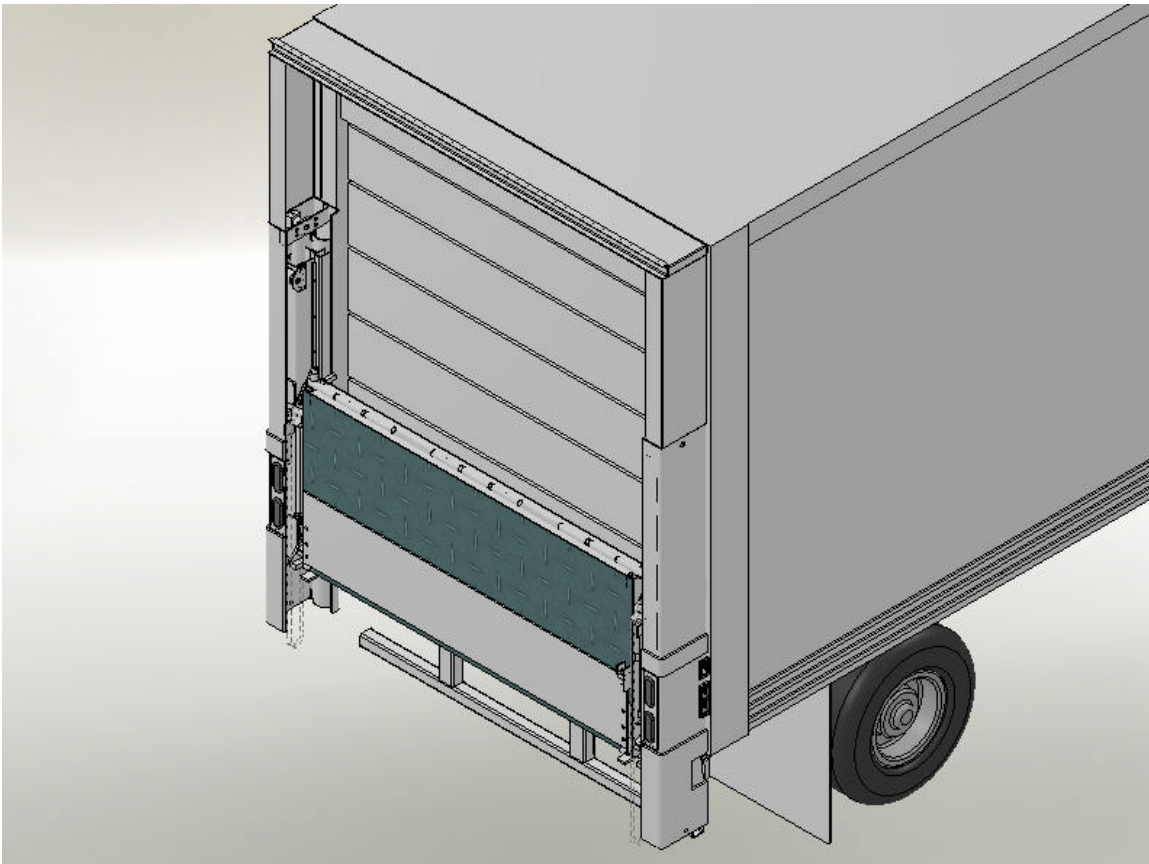

10900 Kenwood Road • Cincinnati, OH 45242
Ph: 513.891.6210 • Toll-Free: 866.539.6261
Fax: 513.891.4901
www.leymanlift.com • sales@leymanlift.com

LML00422-07/08/11

TABLE OF CONTENTS

Introduction	2
Words of Caution	3
Preparation of the Vehicle	4 - 8
Reinforcement for “Break-away” Bodies and Flat Bed Installation	9
Unpacking the FXD®	10 - 11
Standard Bolt-on Kit for FXD®	12
Hoisting the FXD® into Position	13
Welding FXD® to Vehicle	14
Remove Floor Locator Tubes and Shipping Tube	15
Installing the Header Enclosure	16 - 17
Mounting Power Unit Frame	18
Grounding Recommendations for Tractor/Trailer	19
Charge Line – Battery Hook Up	20 – 21
Recommended Hydraulic Oil – Lift Gate Specification	22
Connecting Switch Wiring to Power Unit	23
Dual Power Unit Connections	24 – 25
Hydraulic Lines – gravity down / power down	26 – 29
Bleeding the Lift Cylinders / Bleeding Power Fold Cylinder	30 - 32
Connecting Stop / Tail / Turn Lights	33
Painting the Vehicle	34
Installation of Warning Signs / Decals & Model / Serial No. Tags	35 – 38
Final Installation Inspection	39
Operating the Lift Gate	40
Electrical / Hydraulic Diagrams & Walk Around Electrics (Optional)	41 – 44
Maintenance Minder 2® Controller Menus and Notes	45 – 48

INTRODUCTION

This manual contains the operating procedures on the equipment your company is using that was manufactured by Leyman Manufacturing Corporation.

Past experience has indicated that it is most unwise to operate these units without proper instruction, which should be instituted by the purchaser.

While these products have certain safety features engineered into their design, they are all operated by human beings. Therein lies the problem of safety and one should always have caution in mind when operating this or any other machine that has parts that weigh several hundred pounds.

Again, let us remind you that there are moving parts on this product that weigh several hundred pounds. These parts, when not under proper control, can cause physical damage to operator. Because of the weights that are involved, carelessness and neglect of training can make these units dangerous.

Do not overload this product. Maintain it properly. Stand clear of moving parts. Operate as instructed.

This lift gate has a long life expectancy and will take some abuse. Use good judgment when operating this equipment.

PLEASE FILL IN FOR YOUR RECORDS

CUSTOMER:	_____
MODEL:	_____
CAPACITY:	_____
TYPE:	_____
POWER:	12 VOLT _____
PLATFORM:	_____
SERIAL:	_____
OPTIONS	_____

MAXIMUM HEIGHT:	56"
HYDRAULIC PRESSURE:	AT BY-PASS 2,500 PSI AT THE PUMP
AMP DRAW:	AT BY-PASS 235, UNLOADED 135
GRAVITY DOWN OR POWER DOWN	

**WHEN PLACING PARTS ORDER, YOU WILL NEED
THE SERIAL# AND MODEL# OF THE GATE.**

WORDS OF CAUTION

1. BEFORE ANY MAINTENANCE IS PERFORMED ON THIS UNIT, READ AND UNDERSTAND THIS MANUAL COMPLETELY.
2. DO NOT STAND ON OR BEHIND THE PLATFORM WHEN OPERATING GATE IN THE FOLDED POSITION.
3. DO NOT STAND IN FRONT OF THE PLATFORM WHEN LOWERING FROM VERTICAL POSITION OR OPERATING IN ANY MANNER.
4. MAKE SURE THE GROUND IS CLEAR UNDER THE PLATFORM WHEN LOWERING.
5. CHECK THE AREA AROUND THE UNIT FOR ANY PERSONS BEFORE OPERATING THE LIFT GATE.
6. NEVER EXCEED THE RATED LOAD CAPACITY OF THIS GATE. DO NOT OVERLOAD - MAXIMUM RATED CAPACITY IS BASED ON AN EVENLY DISTRIBUTED LOAD OVER THE PLATFORM FLAT SURFACE.
7. ALWAYS LOAD AS CLOSE TO THE CENTER OF THE PLATFORM AND AS CLOSE TO THE CENTER OF THE TRUCK SILL AS POSSIBLE.
8. DO NOT ALLOW PERSONS TO OPERATE THE UNIT UNLESS THEY HAVE BEEN PROPERLY TRAINED TO DO SO.
9. USE ONLY FACTORY AUTHORIZED PARTS FOR REPLACEMENT.

THIS MANUAL REFLECTS MOST CHANGES AND UPDATES OF MATERIALS THAT ARE COMMON TO THIS TYPE OF LIFT GATE. SOME MAY DIFFER DUE TO INDIVIDUAL CUSTOMER REQUIREMENTS. THIS MANUAL HAS BEEN ESTABLISHED TO REFLECT THE COMMON ITEMS.

WARNING: THIS GATE HAS POLYMER GREASELESS BEARINGS IN THE PLATFORM PIVOTS, AND CYLINDER. WHEN WELDING BE SURE TO GROUND DIRECTLY TO THE COMPONENT BEING WELDED.

PREPARATION OF THE VEHICLE

Read the Installation manual completely before proceeding with the installation of the FXD®.

Do not remove any packing, banding or shipping straps until instructed to do so in the manual.

The FXD® must be installed as described in this manual. Any deviation from the installation method described herein without written permission from Leyman Manufacturing Corporation will void any warranty issued with this unit.

NOTE:

Special preparation must be completed before installing the FXD® on vehicles with aluminum rear corner posts. Contact Leyman Manufacturing Corporation before proceeding with any installation involving aluminum rear corner posts.

NOTE:

The use of a battery charger as the sole power source to operate the lift gate is unauthorized and will prevent the lift gate from working properly. The FXD® must always be operated in conjunction with at least one (1) 12 volt heavy-duty dual purpose or AGM battery on a trailer application, although we recommend using two (2) batteries. A minimum of 9.5 volts must be maintained in order for the valves to operate.

If installing on a truck, you must disconnect the ground from the battery. If this is ignored, the motor controls and charging system can be damaged.

Also, verify that Maintenance Minder 2® Controller has been unplugged before welding the gate to the vehicle, in order to prevent damage to the MM2 Controller.

PREPARATION REQUIRED TO THE REAR OF THE VEHICLE BEFORE MOUNTING GATE TO VEHICLE

There are many different types of trucks and trailers. Some will have to be modified for proper FXD[®] installation. The rear corner posts must be flat and flush with the rear sill. An example is shown below, and over the next few pages, to assist you in preparing the vehicle for lift gate installation.

The shaded area is the surface the FXD[®] mounts to. This area must be all in one plane and square to the ground. This can be accomplished by removing metal or adding fillers.

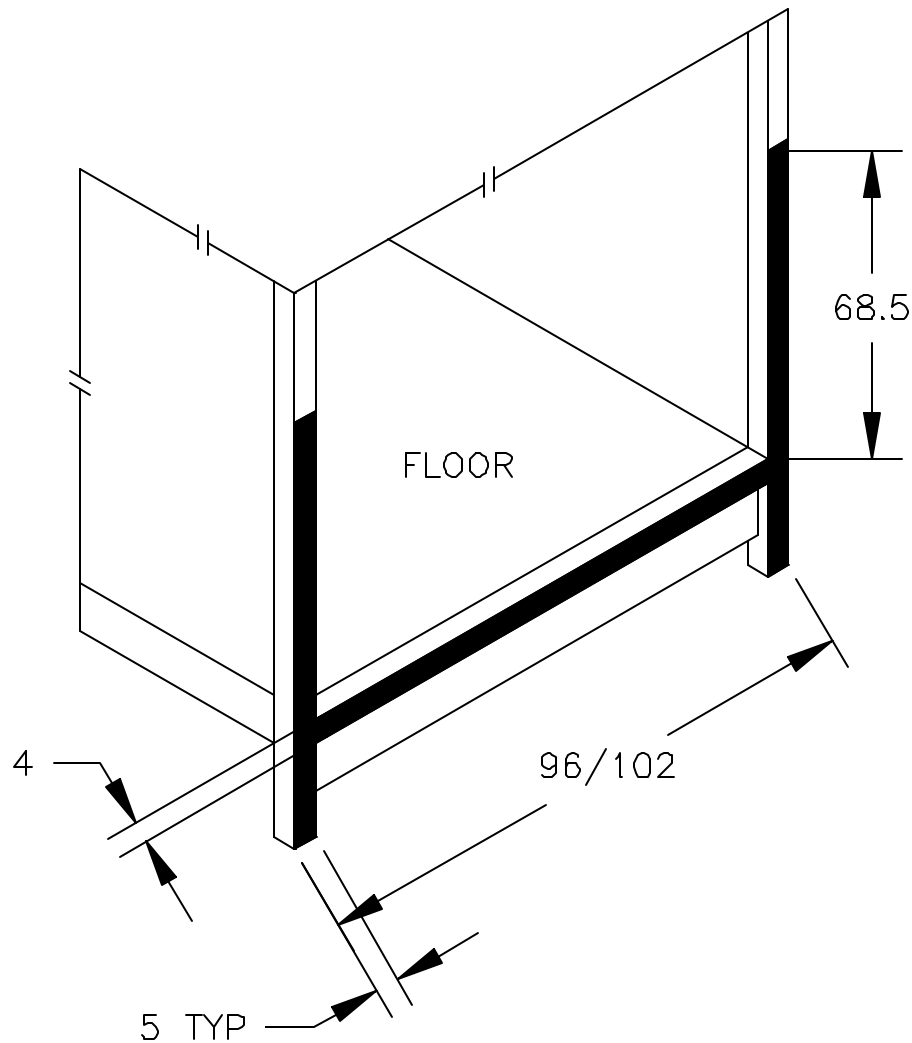

PREPARATION REQUIRED TO THE REAR OF THE VEHICLE BEFORE MOUNTING GATE TO VEHICLE

Cut off obstructions such as light guards and bumper plates that extend beyond the rear sill and rear posts in the areas as shown below. Remove the lights, if permissible. The FXD[®] has LED lights on the masts.

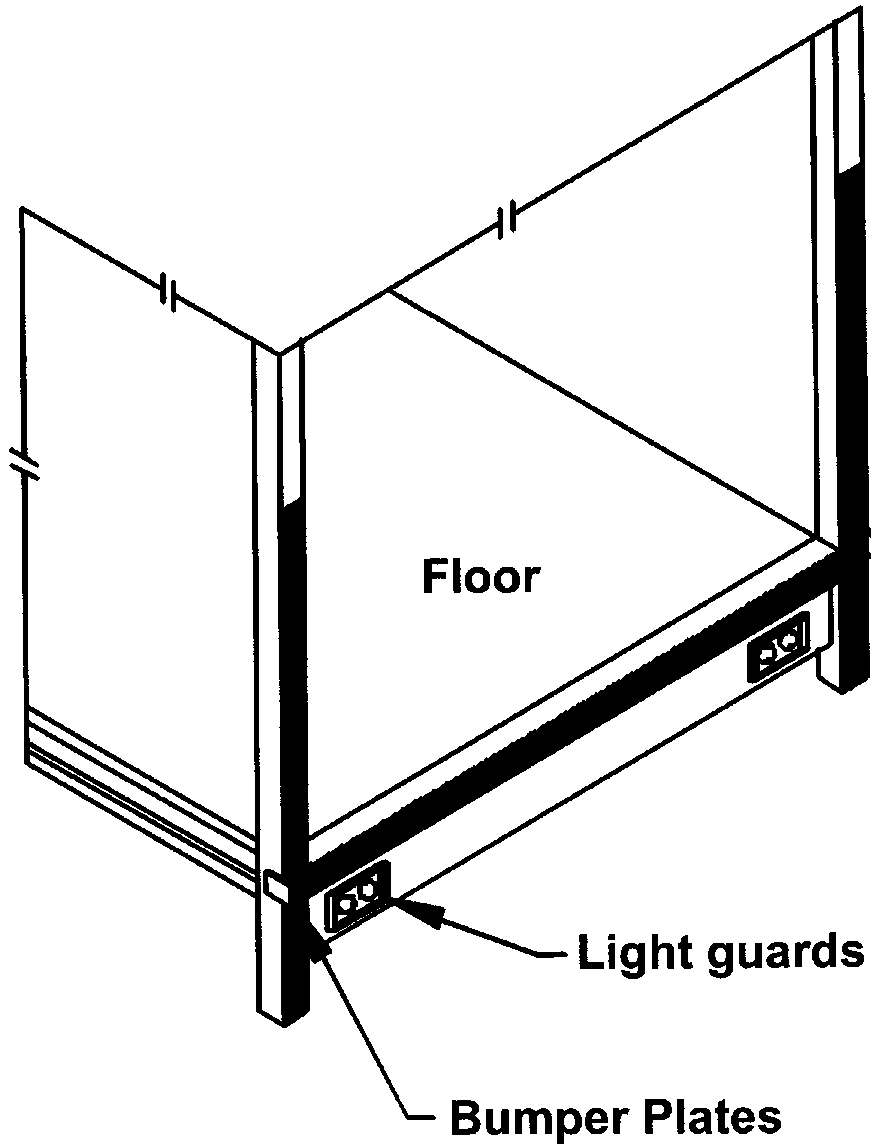

REMOVE METAL TO MAKE A FLUSH SURFACE

PREPARATION REQUIRED TO THE REAR OF THE VEHICLE BEFORE MOUNTING GATE TO VEHICLE

Use 1/4" flat stock as fillers to fill the step down area for the overhead door. Remove the door latch plate, so it can be reinstalled after the floor is filled in. Filler flat stock is not provided by Leyman Manufacturing Corporation.

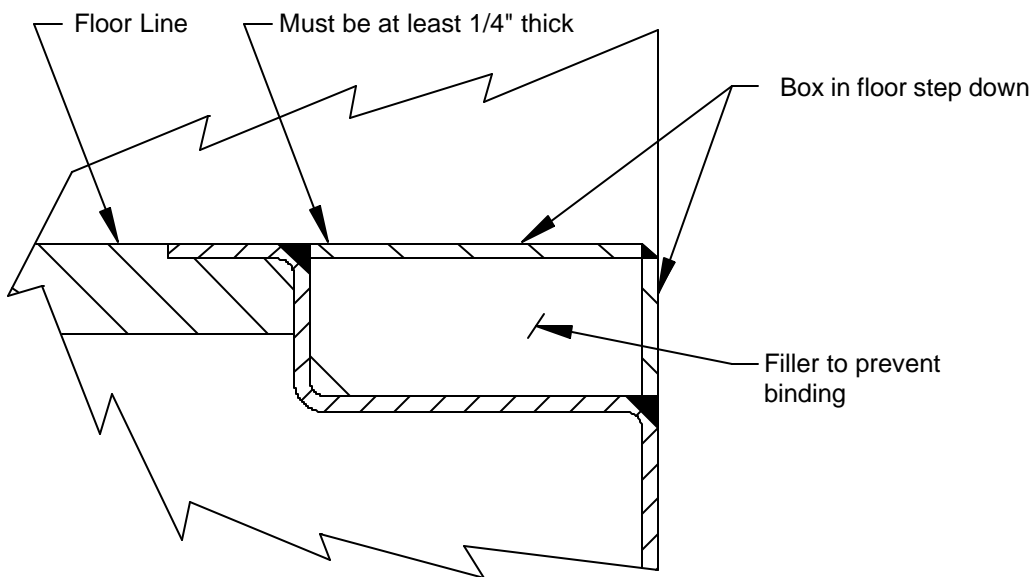
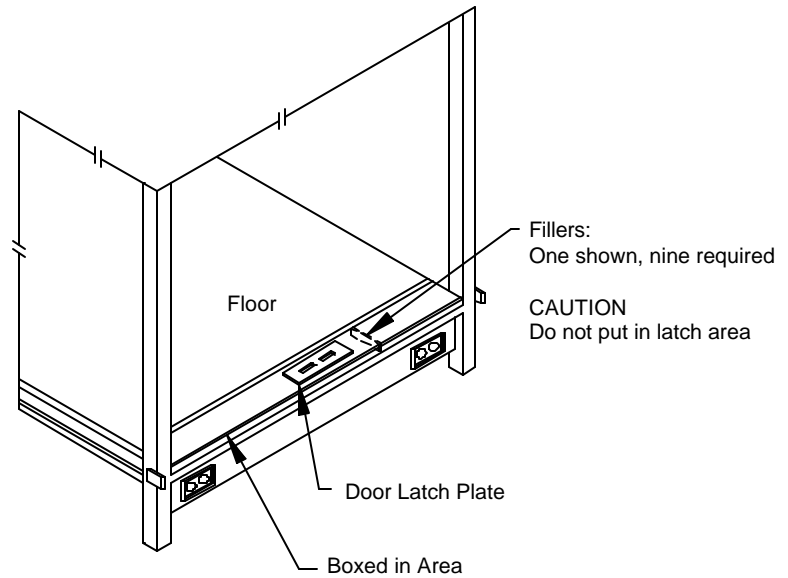

THE BACK OF VEHICLE MUST BE SQUARE

NOTE:

The back of the vehicle must be square to the ground within 1/2" deviation (see drawing). This can be checked with a plum bob. If there is any doubt, weld the FXD[®] temporarily in place, with the Bolt-On Kit attached to the rail gate, then unfold the platform, and lower the platform to ground level. The tip of the platform should touch the ground. If it does not, the gate can be shimmed out until it touches. Then follow all Bolt-On Kit and final welding instructions later.

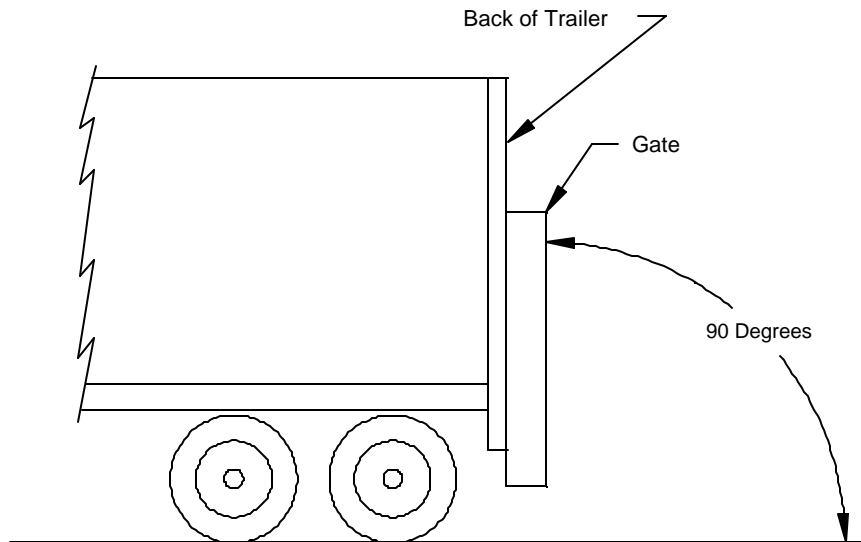

If the vehicle is not square; 4" x 5" long shims maybe used with varying thicknesses to fill the gap. see the "Welding Instructions"

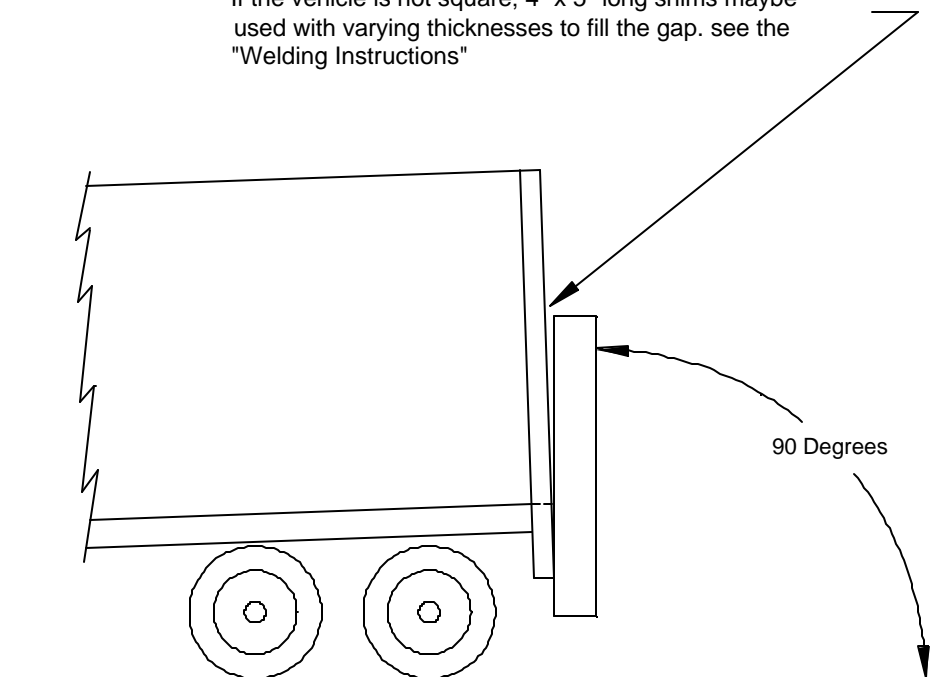

REINFORCEMENT FOR "BREAK-AWAY" BODIES

It is the installer's responsibility to determine if a lift gate is being mounted on a "break-away" style body. If so, all of the bracing listed below must be added. Reinforcement parts are not supplied by Leyman Manufacturing Corporation, unless requested as an option.

NOTES:

1. Cut the bottom brace (Item#3) to length as needed to clear the wheels.
2. Cut the support (Item #4) to length as needed to fit behind the wheels. Cut the ends at 45 degrees.
3. Space supports (Item #8) evenly across the width of the body. Weld to bottom rear sill and the cross members.

ITEM	QTY	DESCRIPTION	MATERIAL
1	2	Top Brace	St. Tube 1 1/2" sq. x 1/8" x 60"
2	2	Gusset	H.R. Flat 1/4" x 4" x 36"
3	2	Bottom Brace	St. Tube 2" sq. x 3/16" x 60"
4	2	Support	St. Tube 2" sq. x 3/16" x 40"
5	12	H.H. Bolt	3/8" - 16 x 2 1/2"
6	12	Hex Nut	3/8" - 16 x 2 1/2"
7	24	Washer	3/8"
8	4	Support	H.R. Flat 1/4" x 4" x 8"

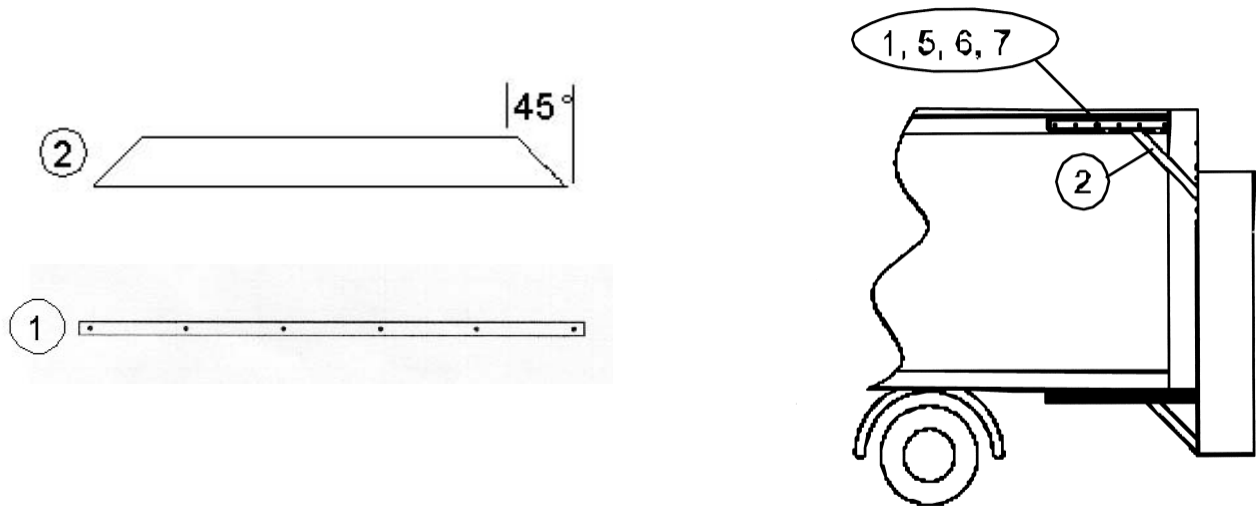

FLAT BED INSTALLATION

The FXD[®] rail gate comes standard with a Bolt-On Mounting Kit. As such, it is not suitable for flat bed installations. Use the FDC-CR rail gates in this case. All flatbed installations require diagonal bracing from the flatbed to the rail gate masts.

UNPACKING THE FXD[®]

The FXD[®] is packaged to protect it during shipping. Do not remove any of the shipping material until the FXD[®] is standing upright on the floor and it is supported by placing the forks of a forklift under the shipping tube. Once this is done, remove only the shipping material as shown. The remaining items will not be removed until the gate is completely installed on the vehicle. Bolt-On Kit is NOT shown on gate mounting face.

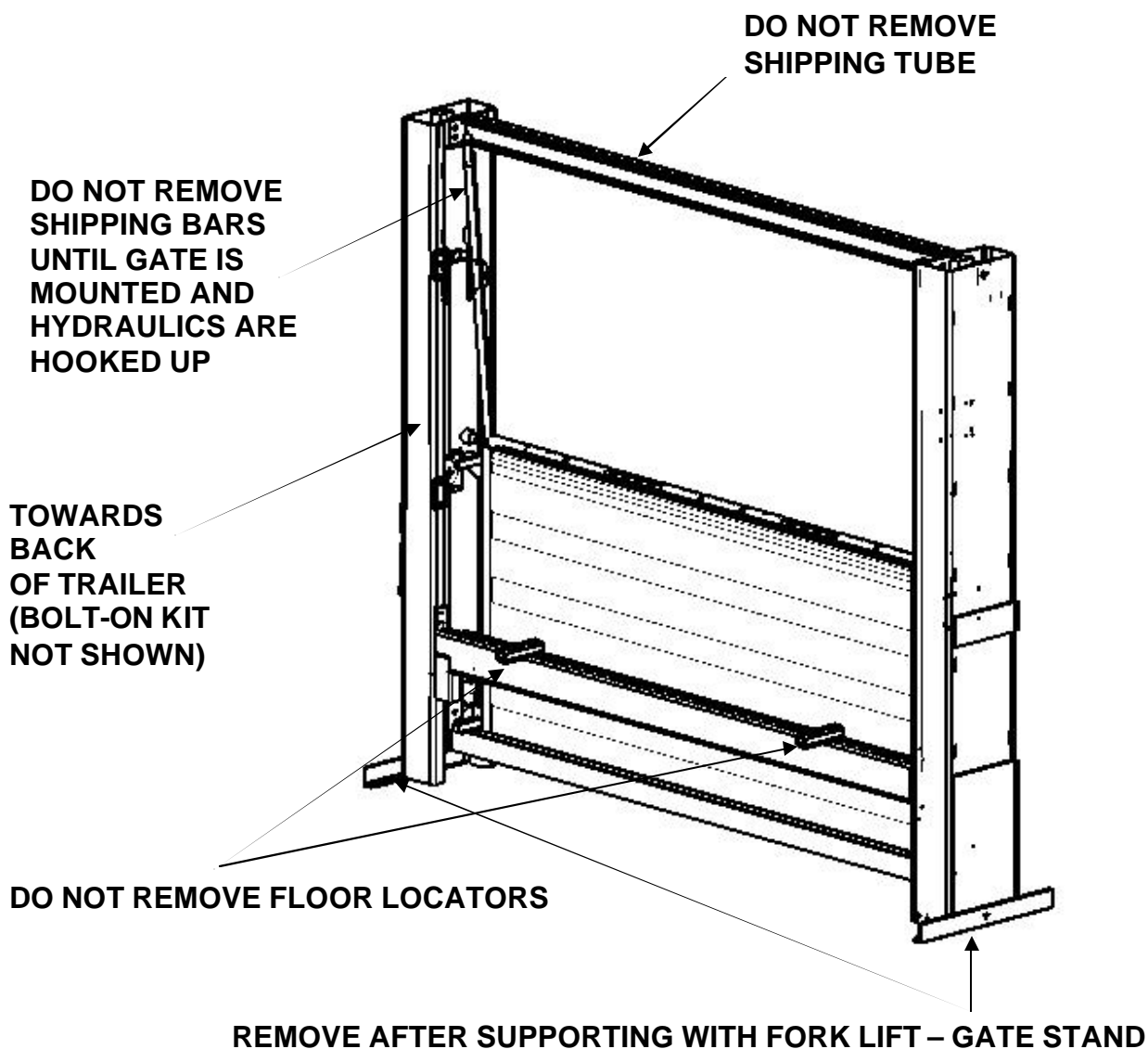

UNPACKING THE FXD® (cont.)

CAUTION

Always use a safety chain so the lift gate can not slide off the forks.
Lift FXD® slowly to vertical position, pictured below.

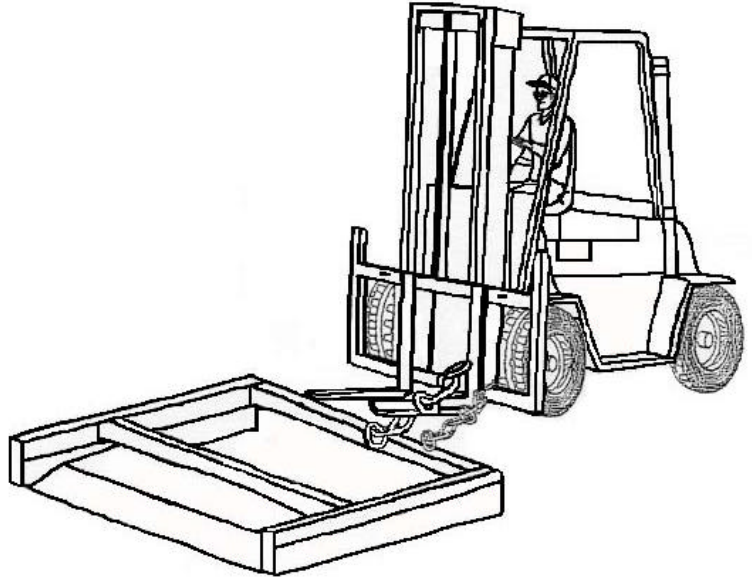

Clamp forks to the shipping tube as shown in picture below.

CAUTION

Do not remove shipping tube or the platform support bars until the hydraulics and power pack are hooked up and the gate, with Bolt-On Kit, is welded solid to the vehicle.

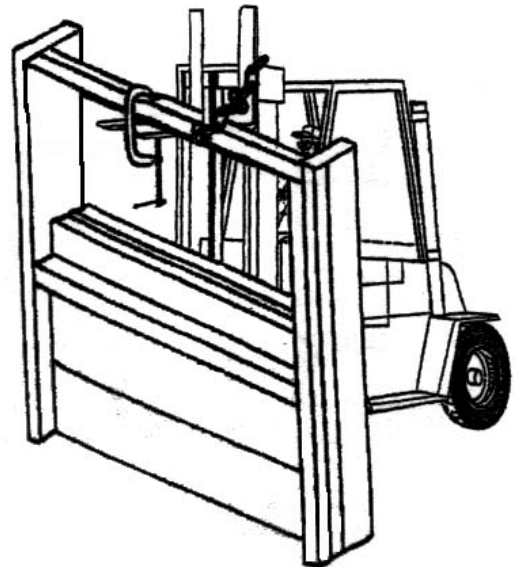

STANDARD BOLT-ON KIT for FXD®

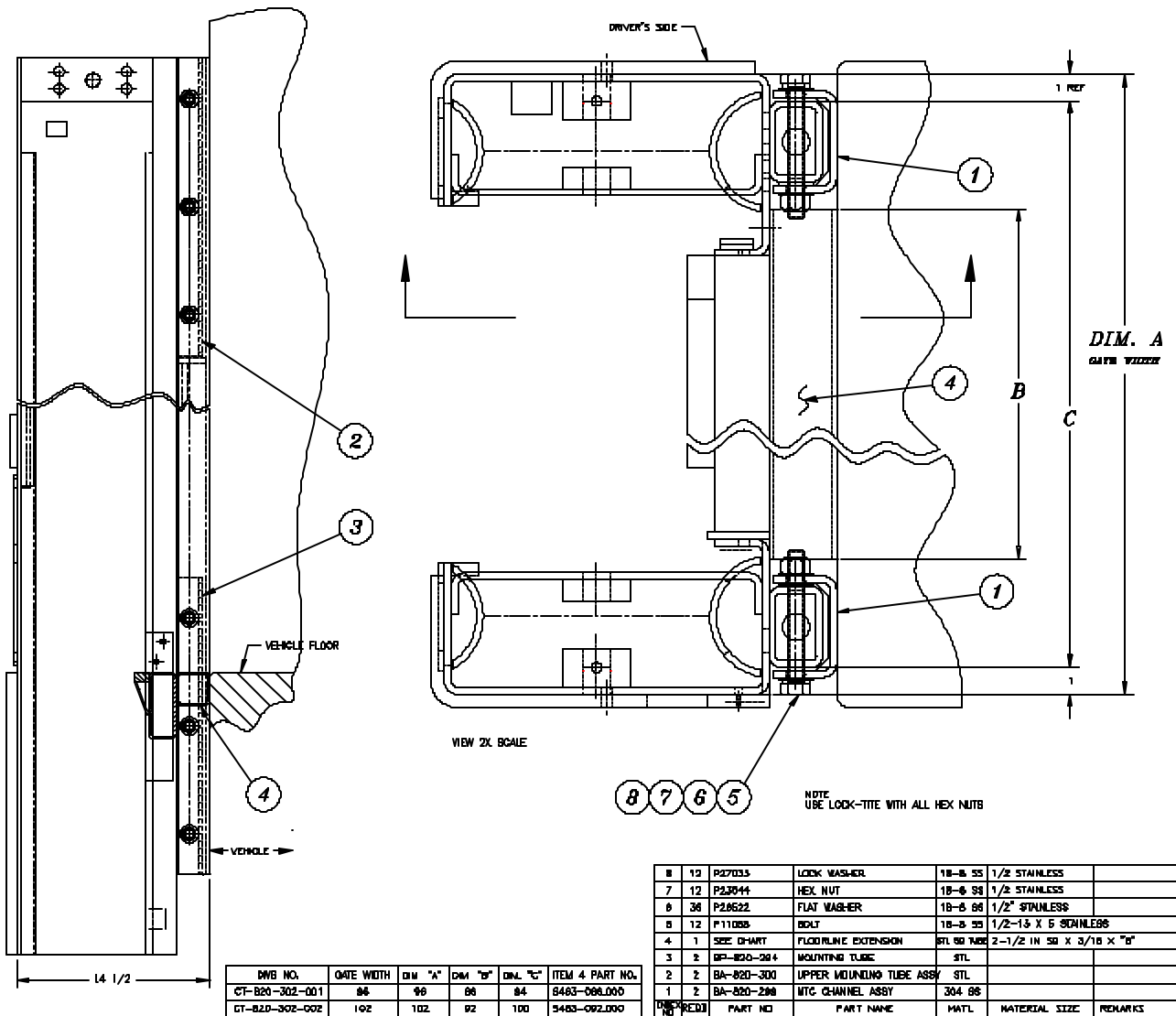

The primary purpose of the Bolt-On Kit is to avoid damage to the Extreme Shield® paint during welding. Item 1, which must be welded to the vehicle, is unpainted stainless steel. The Bolt-On Kit comes fully assembled to the lift gate rails. It can remain assembled during installation.

IMPORTANT! When welding the stainless steel Mounting Channels (Item 1) to the rear frame of the vehicle (which could be either mild steel or stainless steel), you **must** use stainless steel welding wire in order to achieve good quality welds.

CAUTION! The Bolt-On Kit offsets the lift gate Outer Masts 2-1/2" from the rear face of the vehicle. This means that the Rear Impact Guard must be brought back within the 12" horizontal limit. The 1/2" thick steel bumper plates on the lift gate Outer Masts are excluded from the 12" maximum dimension. Consult trailer manufacturer for Rear Impact Guard kits that are available to make up for this 2-1/2".

HOISTING THE FXD[®] INTO POSITION FOR INSTALLATION

Lift the FXD[®] off the ground with a forklift and approach the vehicle.

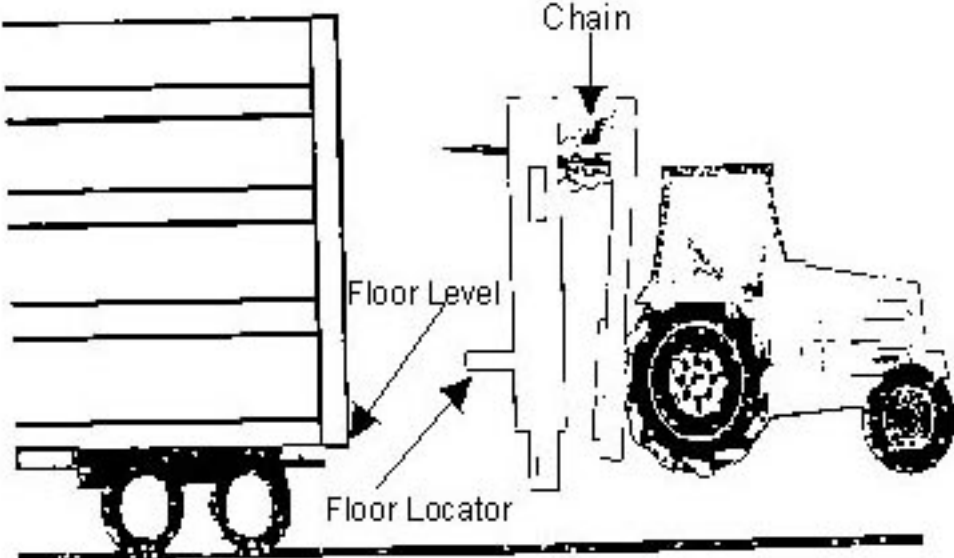

NOTE:
The floor locators must rest on the vehicle.

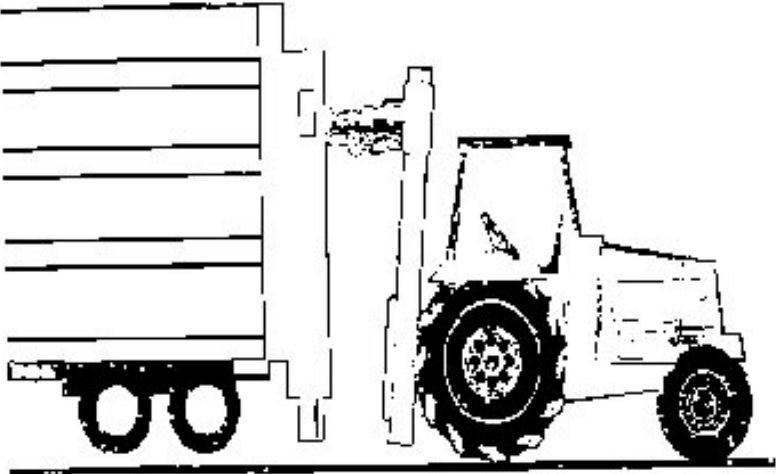

WELD FXD[®] TO VEHICLE

Center the FXD[®] on the vehicle. Once the gate is centered, and resting on the vehicle floor, weld stainless steel Mounting Channels on Outer Masts to vehicle.

Use ¼" fillet welds 2" long and spaced 10" apart on both inside and outside vertical surfaces of the Mounting Channels. No welds are required across the Floor Line Extension Tube (Item 4 on the Bolt-On Kit drawing, p.12)

The two vertical rails must be welded to Vehicle both Inside and Outside

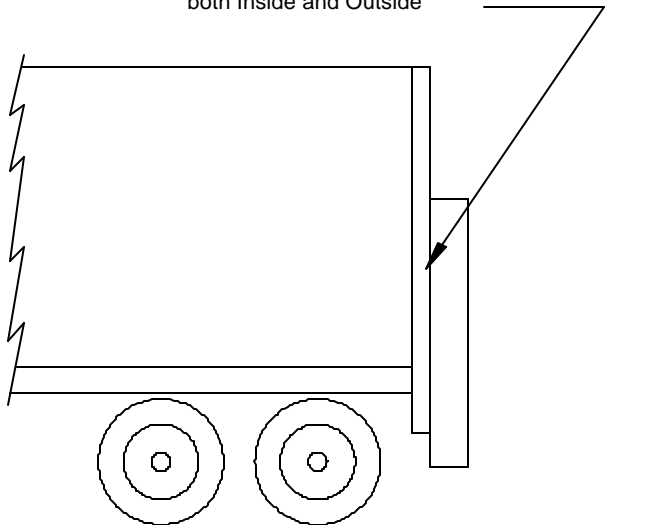

REMOVE FLOOR LOCATOR TUBES AND SHIPPING TUBE

Once the lift gate has been welded to the vehicle and meets previous stated specifications, remove floor locator tubes, unbolt the platform support straps while supporting the platform, and remove the shipping tube by unbolting.

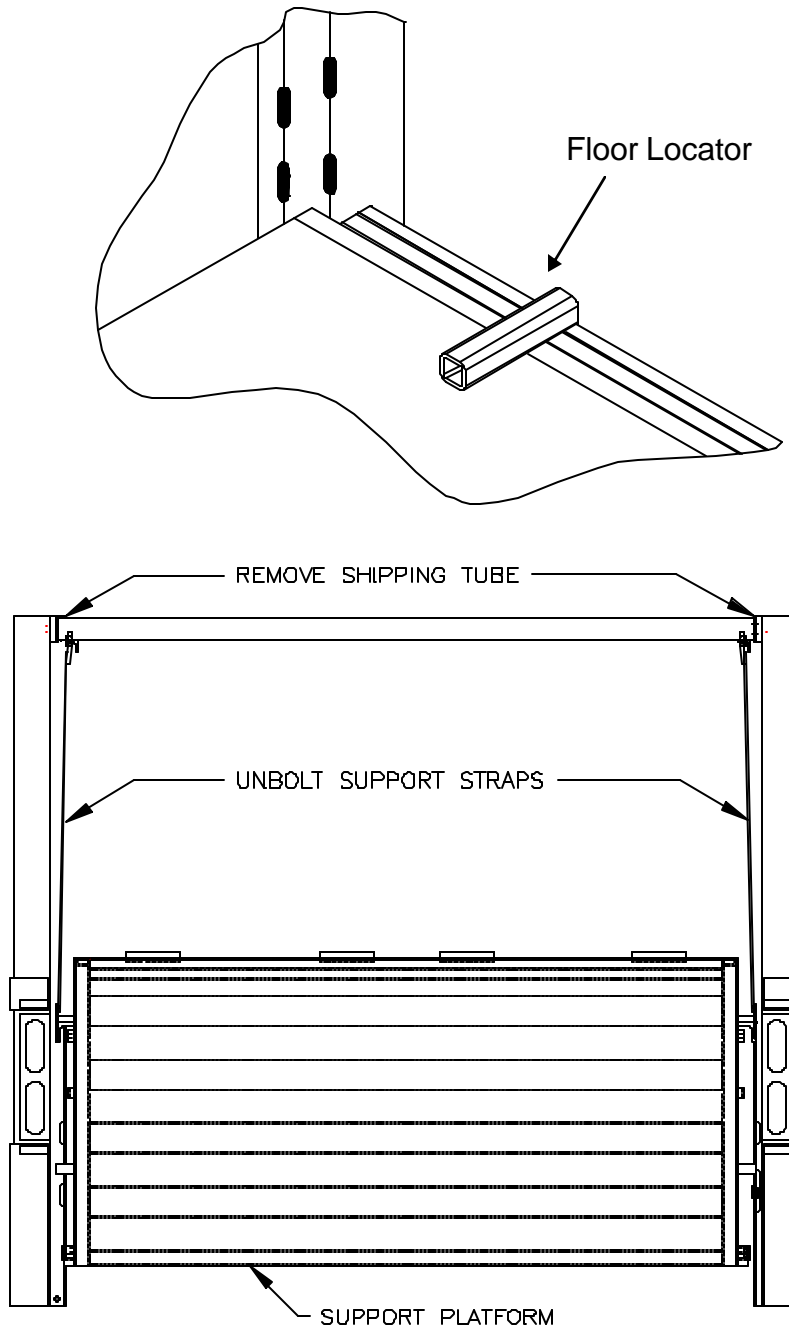

INSTALLING HEADER ENCLOSURE

The Header Kit is a standard item on FXD[®]. The general method of installation is shown here. More detailed instructions are on the next page. Attach Header Kit to vehicle using rivets supplied to prevent damage to Extreme Shield[®] paint. **DO NOT WELD.**

Measure the distance from the top of the mast to the vehicle header.

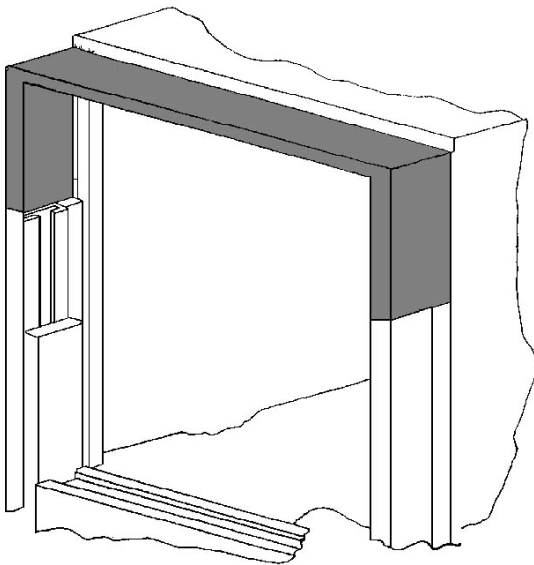
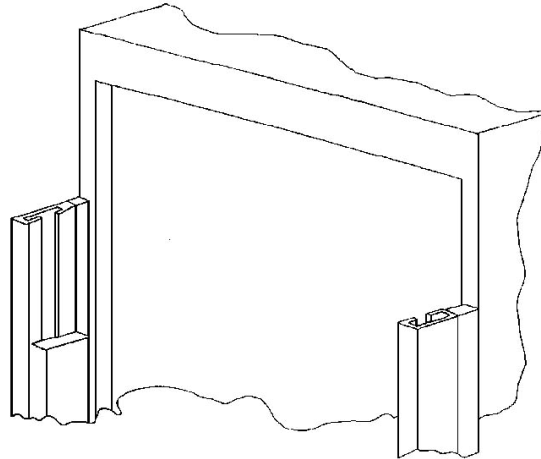

Trim the sides of the header enclosure to match the vehicle opening. Assemble header sides to top following instructions on next page. Use Extreme Shield touch-up paint kit where necessary.

3" channel at the top of the header faces to the rear, NOT against the vehicle header. The lights can be installed inside the channel.

INSTALLING HEADER ENCLOSURE (cont.)

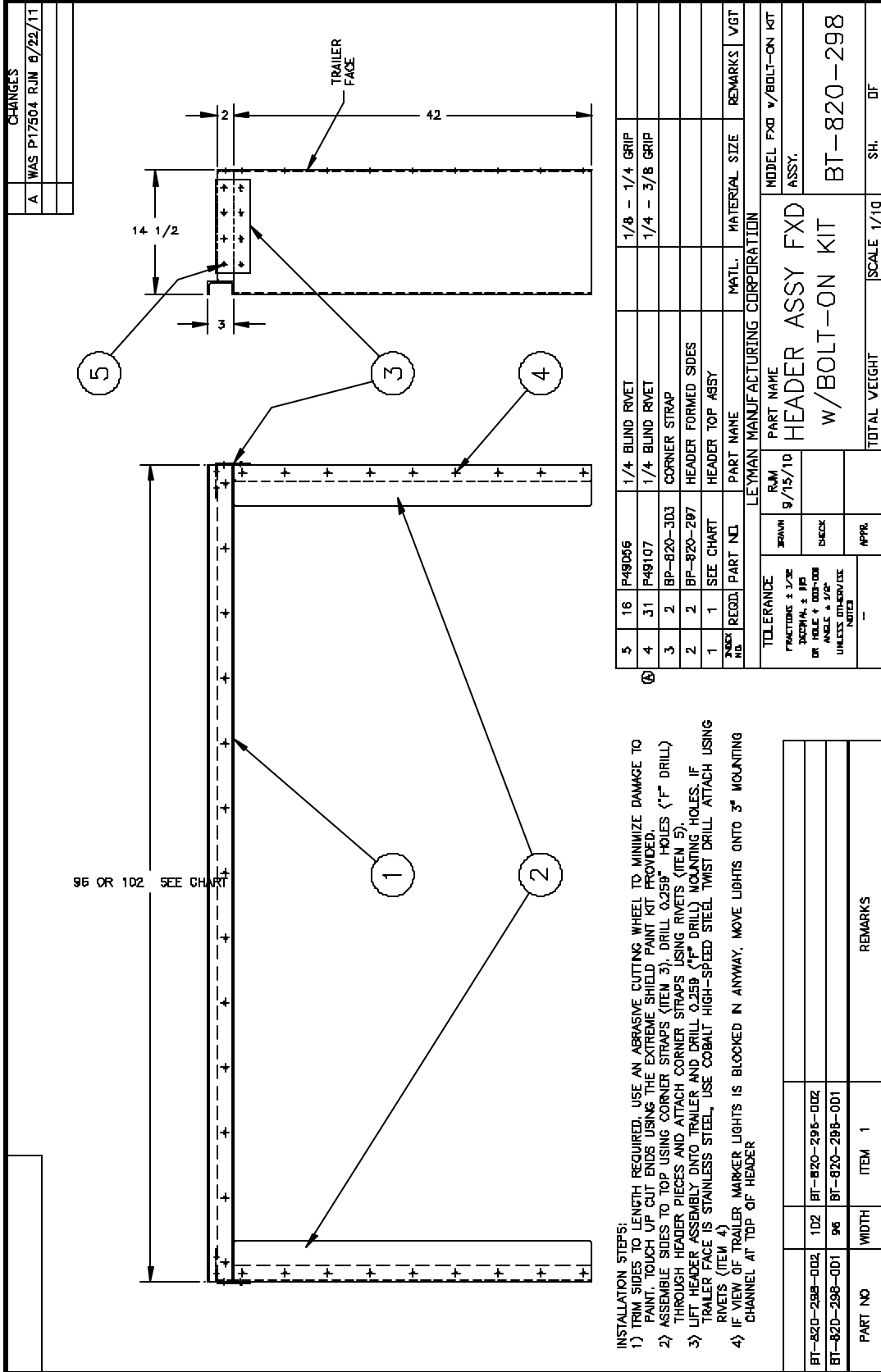

CHANGES	
A	WAS P17504 R.I.N. 8/22/11

5	16	P48056	1/4 BLIND RIVET	1/8 - 1/4 GRIP		
4	31	F48107	1/4 BLIND RIVET	1/4 - 3/8 GRIP		
3	2	BP-820-3D3	CORNER STRAP			
2	2	BP-820-297	HEADER FORMED SIDES			
1	1	SEE CHART	HEADER TOP ASBY			
PART NO.	REQD.	PART NO.	PART NAME	MATL.	MATERIAL SIZE	REMARKS VGT
LEYMAN MANUFACTURING CORPORATION						
TOLERANCE		RAM	PART NAME		MODEL FXD	V/BOLT-ON KIT
FRACTIONS ± 1/32		9/15/10	HEADER ASSY FXD		ASSY.	
DECIMALS ± .01		CHECK	w/BOLT-ON KIT			BT-820-298
DI HOLE ± .00100		APPR	TOTAL VEIGHT		SCALE	1/10
ANGLE ± 1/2°					SH.	DT
UNLESS OTHERWISE NOTED						

- INSTALLATION STEPS:
- 1) TRIM SIDES TO LENGTH REQUIRED. USE AN ABRASIVE CUTTING WHEEL TO MINIMIZE DAMAGE TO PAINT. TOUCH UP CUT ENDS USING THE EXTREME SHIELD PAINT KIT PROVIDED.
 - 2) ASSEMBLE SIDES TO TOP USING CORNER STRAPS (ITEM 3). DRILL Ø.259" HOLES (1" DRILL) THROUGH HEADER PIECES AND ATTACH CORNER STRAPS USING RIVETS (ITEM 5).
 - 3) LIFT HEADER ASSEMBLY ONTO TRAILER AND DRILL Ø.259 (1" DRILL) MOUNTING HOLES. IF TRAILER FACE IS STAINLESS STEEL, USE COBALT HIGH-SPEED STEEL TWIST DRILL ATTACH USING RIVETS (ITEM 4)
 - 4) IF VIEW OF TRAILER MARKER LIGHTS IS BLOCKED IN ANYWAY, MOVE LIGHTS ONTO 3" MOUNTING CHANNEL AT TOP OF HEADER

BT-820-298-002	102	BT-820-298-002	
BT-820-298-001	96	BT-820-298-001	
PART NO	WIDTH	ITEM	REMARKS
		1	

MOUNTING POWER UNIT FRAME

Mount the power unit frame as close to the electrical source as possible. Center the power unit frame under the vehicle and weld to all "I" beams that the power unit frame touches. Use full welds. When installing the power unit frame to a truck, you may mount it on either side, however, we recommend the installation on the curbside of the vehicle.

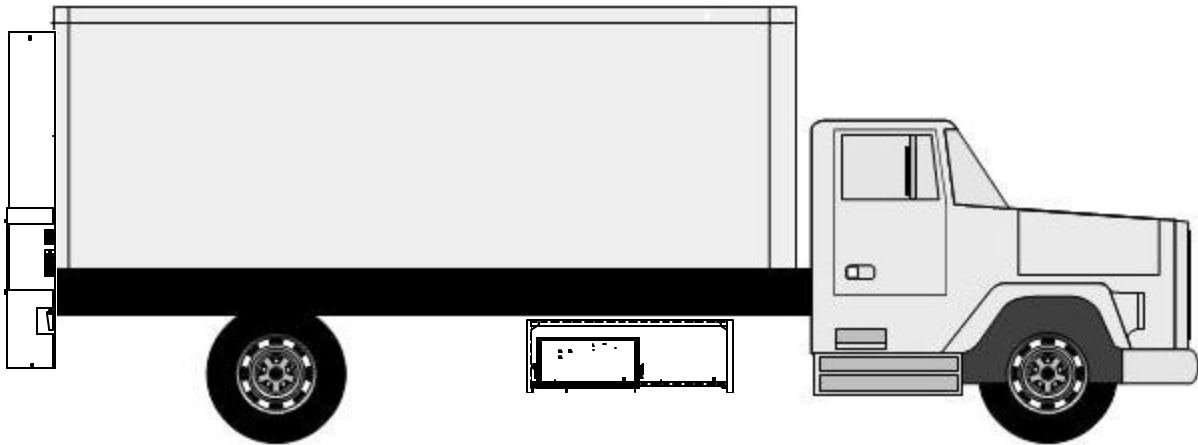

When mounting power unit frame on truck body cross-members, Installer **MUST INSTALL** a ground wire between the power unit frame and the truck chassis ground. Wire **NOT** supplied by Leyman.

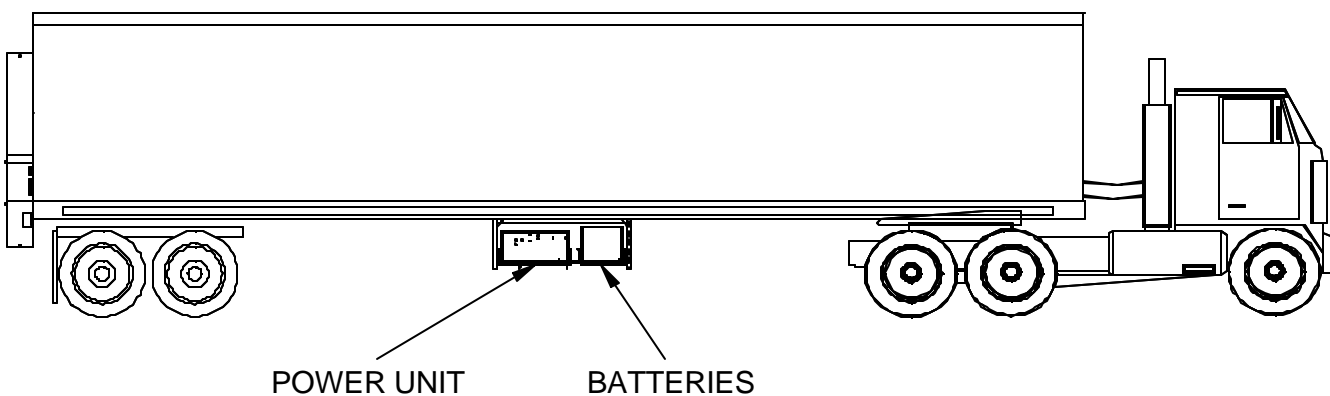

GROUNDING RECOMMENDATIONS FOR TRACTOR/ TRAILER

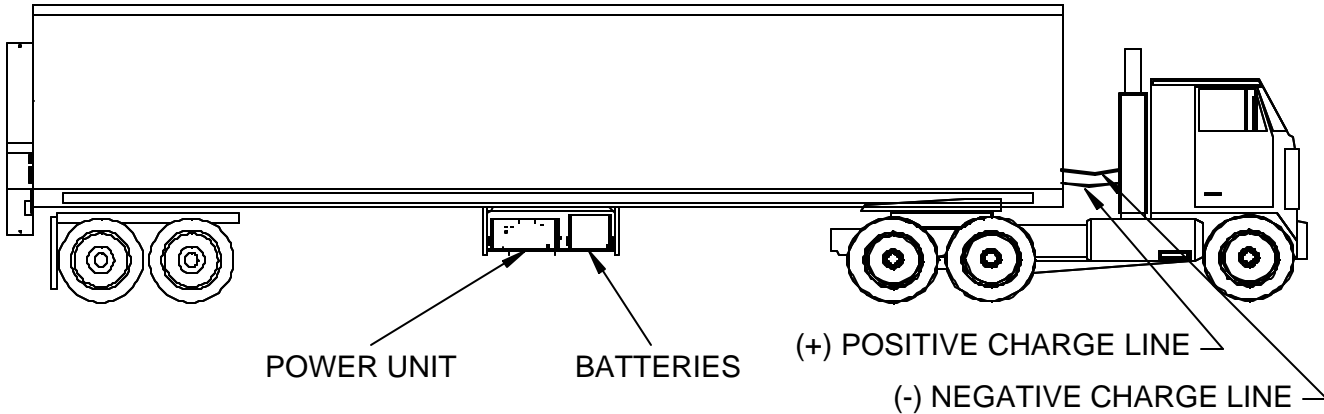

The MAINTENANCE MINDER 2[®] controller requires that a minimum of 8 volts be maintained under load in order for the FXD[®] power unit to operate. Utilization of a single positive cable does not provide sufficient ground. Therefore, our recommendation for grounding tractor/trailers with a FXD[®] gate is as follows:

Two (2) cables: one (1) positive and one (1) negative, both running to the tractor batteries.

NOTE:

The use of a battery charger as the sole power source to operate a FXD[®] is unauthorized and will prevent the FXD[®] from working properly. The lift gate must always be operated in conjunction with at least one (1) 12-volt dual purpose heavy-duty lift gate battery. A minimum of 10.5 volts must be maintained in order for the valves to operate.

CHARGE LINE

When installing the charge line, be sure the cable goes through three (3) "I" beams at the very least, past the fifth wheel plate and through the clear vinyl loom. Mount the remaining cable with loom clamps and self-tapping screws to the "I" beams.

USE "0" GAUGE CABLE AT MINIMUM

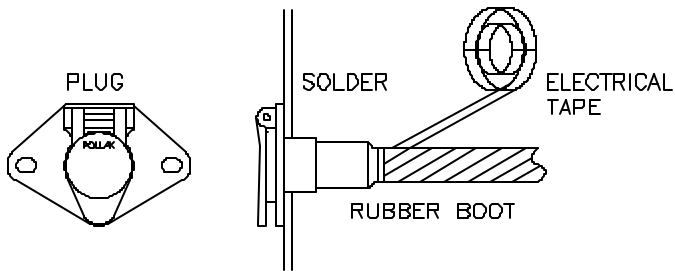

WE RECOMMEND THAT YOU USE AT LEAST A 90 AMP ALTERNATOR ON THE TRACTOR TO RECHARGE THE BATTERIES ON THE FXD®.

NOTE: We recommend that you take the vehicle to a refrigeration distributor if the reefer unit will be used for recharging

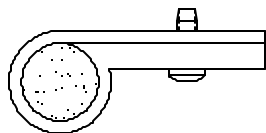
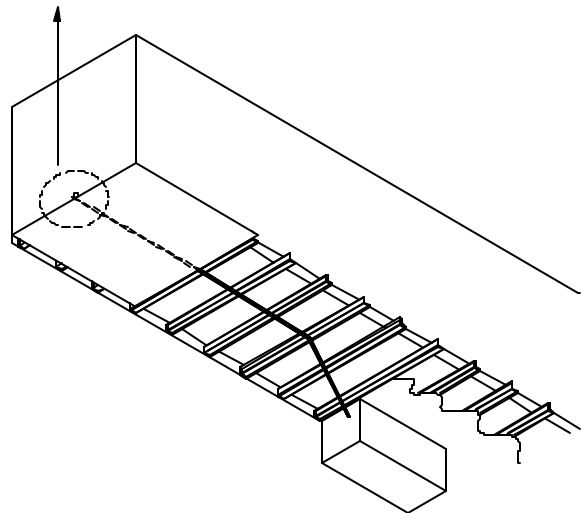

TRACTOR PLUG

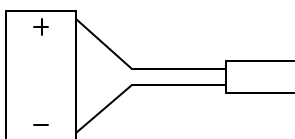

The plug that is on the tractor must have a hot wire and ground wire to the lug that plugs into the trailer.

BATTERY HOOK UP

We recommend batteries with the following specifications:
12 Volt Heavy Duty Lead Acid Dual Purpose or AGM
B.C.I. Group – Size 31
Terminal Type – TS
Cold Cranking Amps - 580

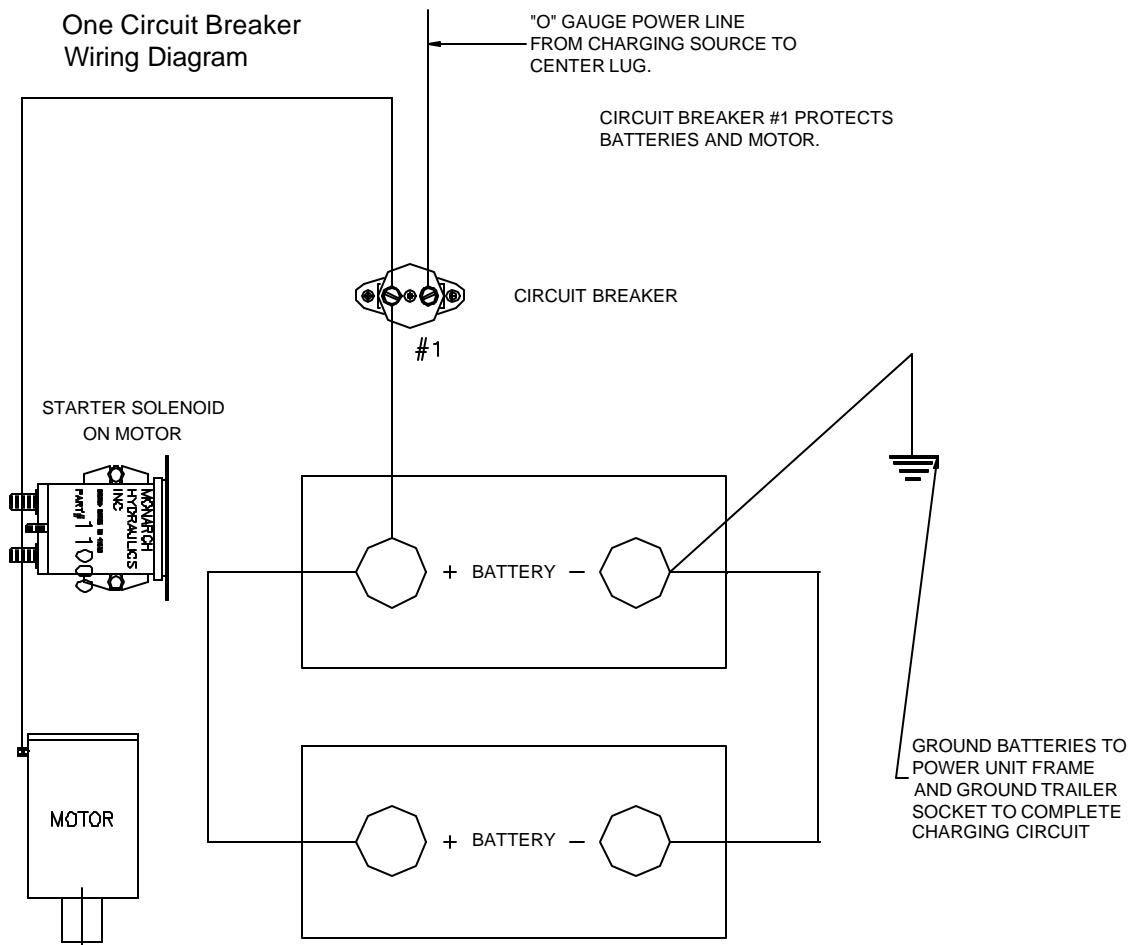

FAILURE TO USE CORRECT BATTERIES WILL VOID WARRANTY

Place rubber pads under each battery to prevent movement, and securely tighten Battery Clamp.

RECOMMENDED HYDRAULIC OILS

HYDRAULIC OILS	MANUFACTURER	TYPE	TEMP. RANGE
Level 1 Normal Conditions	Mobile	DTE 11	-15° F to + 150° F
	Shell	TELLUS-T15	-15° F to + 150° F
	Chevron	RYKON ISO-15	-15° F to + 150° F
Level 2 Cold Conditions	Mobile	AERO-HFA	-50° F to + 80° F
	Shell	AERO FLUID#4	-50° F to + 80° F
	Chevron	AVIATION-A	-50° F to + 80° F
HYDRAULIC TANK CAPACITY			
2 ½ gallons			
LUBRICATION			
Grease	Militec #1 (or Lithium base NLGI grade 1 grease)		
Rollers at Inner Masts	CAUTION! Do not over-grease to avoid seal damage		
Hinge Barrels (center of platform)	W.W. Grainger – Part #6Y834 – Needle Nose Adapter		
Retention Ramp hold-up tab shaft	W.W. Grainger – Part #6Y834 – Needle Nose Adapter		
Dry Lubricant, if needed	ZEP45 (do not use corrosive lubricants like WD40, etc.)		

LIFT GATE SPECIFICATION

BATTERIES
Two (2) 12 V D.C. Group 31 Heavy Duty Lead Acid Dual Purpose or AGM
ELECTRICAL COMPONENTS CONNECTIONS
Use Fluid Film Rust & Corrosion Protection by Eureka, except on Start Solenoid On Start Solenoid, use Color Guard by Loctite, or Liquid Electrical Tape
AMPERAGE DRAW OF MOTOR
When raising platform (empty) approximately 140 AMPS @ 13.5 volts. At bypass approximately 240 AMPS @ 13.5 volts
LIFTING PRESSURE SETTING
With platform at floor level and pump in bypass 2500 PSI Power down circuit in bypass 500 PSI
MINIMUM VEHICLE FLOOR HEIGHT LADEN
With Inner Platform 42" – vehicle floor height 46"
MAXIMUM VEHICLE FLOOR HEIGHT UNLADEN
With Inner Platform 42" – vehicle floor height 56"
APPROXIMATE TIMES EMPTY AT 80° F WITH 2 GROUP 31 BATTERIES
Time up: 22 – 24 seconds Time down(gravity down): 12 –14 seconds Time down(power down): 14 – 16 seconds

CONNECTING SWITCH WIRING TO POWER UNIT

The FXD[®] arrives with the electric wiring connected to both the inside and outside toggle switches. Use the loom clamps and self-tapping screws to unroll and connect the wire to the underside of the "I" beams (pictured below). Then route cable through power unit box cord grip and connect all leads with fork terminals to the center screws on the Selector Switches. Temporarily unbolt Selector Switch bracket. Follow wiring diagram to match wire colors. NOTE that the BLACK WIRE from the lift gate switches is BUTT CONNECTED to a single black lead coming from the Maintenance Minder 2[®]. See Selector Switch detail drawings on the next two pages for further details.

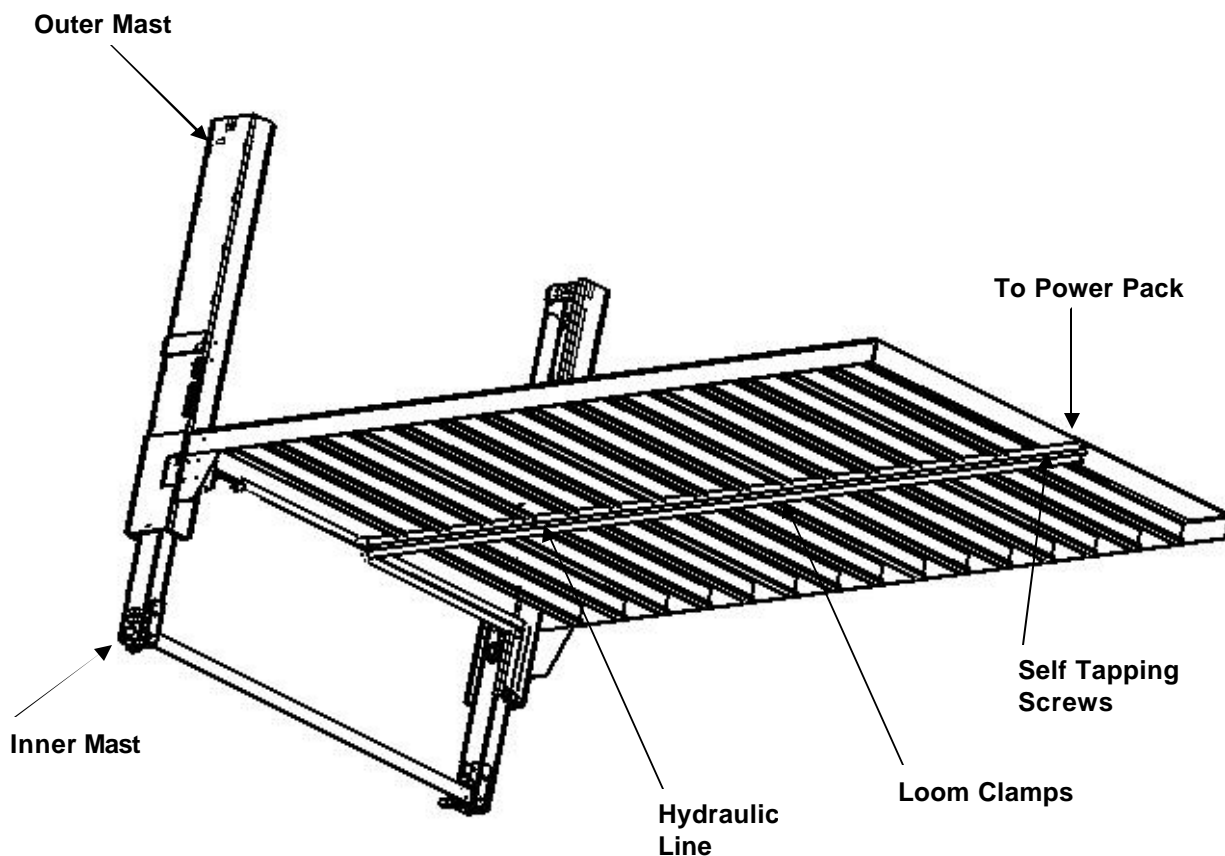

Wire mounts to underside of "I" beams

DUAL POWER UNIT CONNECTIONS

CONNECTING THE GATE SWITCHES TO POWER UNIT – GRAVITY DOWN

ROUTE THE CABLE FROM THE GATE SWITCHES INTO THE POWER UNIT ENCLOSURE. FOLLOW THE DUAL GRAVITY DOWN DIAGRAM. THE ORANGE, GREEN, WHITE, AND RED WIRES WITH FORK TERMINALS CONNECT TO THE CENTER COLUMN OF THE SELECTOR SWITCHES. USE ONLY THE OPEN POSITIONS ON THE CENTER SCREWS. MATCH COLOR TO COLOR ACROSS THE ROWS FOR PROPER OPERATION. THE BLACK WIRE IS BUTT CONNECTED TO THE BLACK WIRE FROM THE MAINTENANCE MINDER 2.

NOTE: THE SELECTOR SWITCH BRACKET CAN BE UNBOLTED TO MAKE THE CONNECTIONS EASIER TO ACCESS.

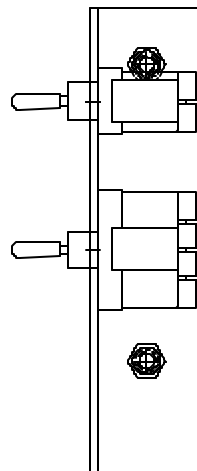
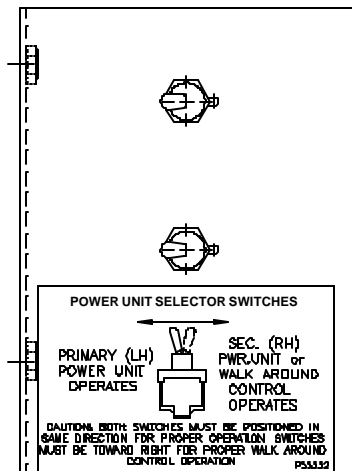
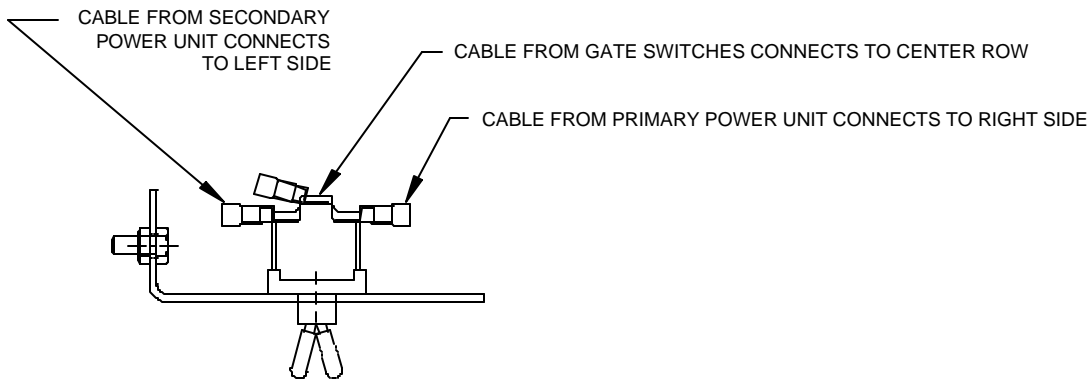

CONNECTIONS VIEWED FROM REAR

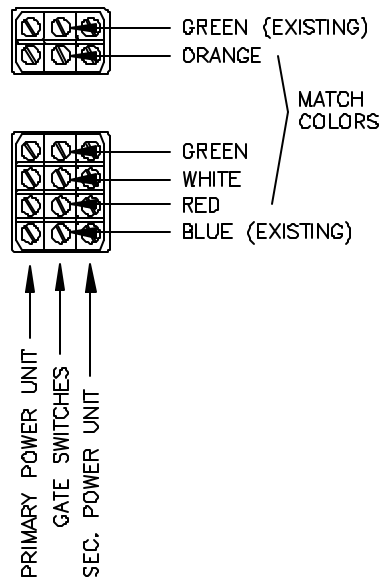

DUAL POWER UNIT CONNECTIONS (Cont.)

CONNECTING THE GATE SWITCHES TO POWER UNIT – POWER DOWN

ROUTE THE CABLE FROM THE GATE SWITCHES INTO THE POWER UNIT ENCLOSURE. FOLLOW THE DUAL POWER DOWN DIAGRAM. THE ORANGE, GREEN, WHITE, AND RED WIRES WITH FORK TERMINALS CONNECT TO THE CENTER COLUMN OF THE SELECTOR SWITCHES. USE ONLY THE OPEN POSITIONS ON THE CENTER SCREWS. MATCH COLOR TO COLOR ACROSS THE ROWS FOR PROPER OPERATION. THE BLACK WIRE IS BUTT CONNECTED TO THE BLACK WIRE FROM THE MAINTENANCE MINDER 2.

NOTE: THE SELECTOR SWITCH BRACKET CAN BE UNBOLTED TO MAKE THE CONNECTIONS EASIER TO ACCESS.

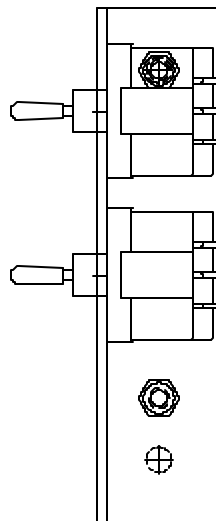
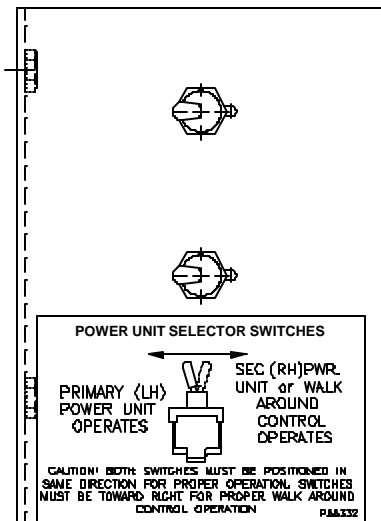
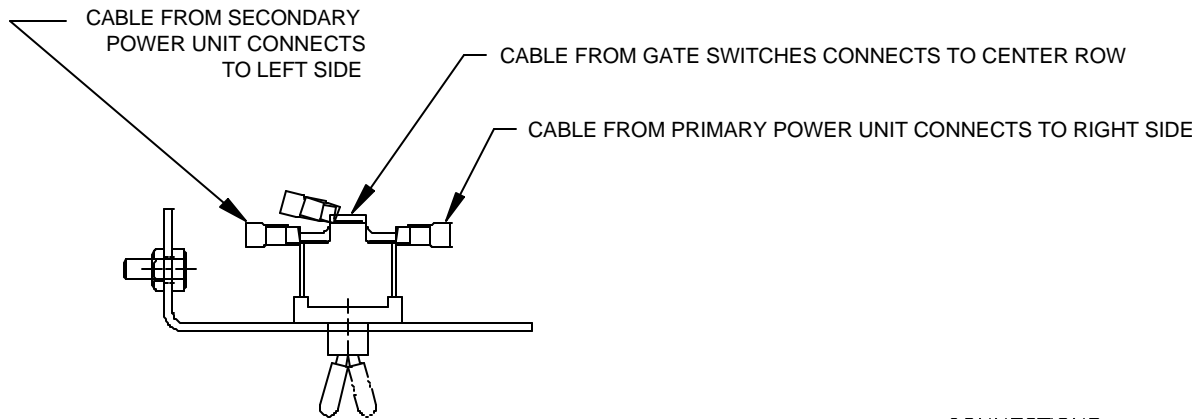

CONNECTIONS VIEWED FROM REAR

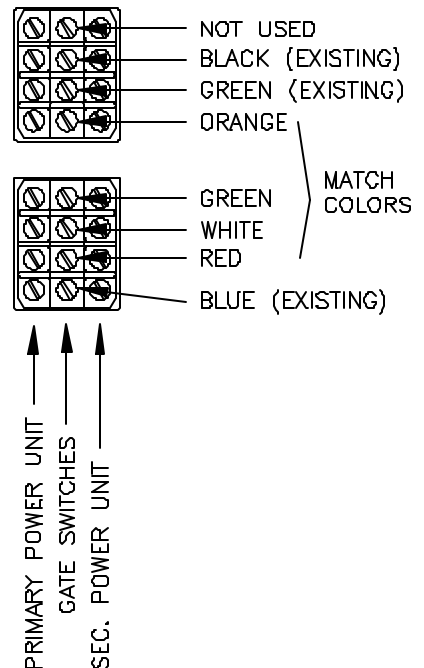

HYDRAULIC LINES – GRAVITY DOWN

Up/ Down Lines: First fill both tanks with a recommended hydraulic oil to within 2” from the top. Then connect one of the hydraulic lines to one of the exit ports of the equalizer valve behind the power unit. Take the second up/down line and connect it to the other exit port. Run both lines back to the gate. **BEFORE CONNECTING TO BULKHEAD ELBOWS ON GATE, RUN THE POWER UNIT TO FILL THE LINES WITH OIL.** Next, remove the caps on the bulkhead elbows at the bottom of the left Outer Mast and connect the hydraulic lines. See sketch on next page for port identification. Elbow fittings are provided with the hose kits to route the hoses straight up from the rail gate mast to the vehicle cross-members, if desired. Attach the hydraulic lines to the body cross-members with loom clamps and self-tapping screws provided in the lift gate kit.

NOTE: This procedure should minimize the amount of air trapped in the cylinders or hydraulic lines. If the gate does not raise and lower smoothly, see page on bleeding the lift cylinders before making any other adjustments.

Power Fold Line: Connect the hydraulic line to bulkhead fitting mounted at the back of power unit box and run the line back to the bulkhead elbow at the bottom of the left Outer Mast. Make sure this elbow is the one connected to the hydraulic line that is hooked up to the folding cylinder. **BEFORE CONNECTING TO THE ELBOW, RUN THE POWER UNIT TO FILL THE LINE WITH OIL.** Next, remove the plug in the bulkhead elbow and connect the hydraulic line. Attach the line to the body cross-members with loom clamps and self-tapping screws provided in the lift gate kit.

NOTE: This procedure should minimize the amount of air trapped in the fold cylinder or hydraulic line. If the gate does not fold and unfold smoothly, see page on bleeding the fold cylinder before making other adjustments.

Vent Line: Connect the poly-tube line to the power pack at the fitting in the top of the reservoir tank and run back to the vent port located at the bottom of the left Outer Mast. Route the poly-tube along side the Up/Down lines and secure to one of the Up/Down lines using cable ties provided in the lift gate kit.

Oil Level check: After all hydraulic lines have been connected, unfold and lower the gate platform to the ground and check the oil level in the tanks. Wait several minutes for oil level in both tanks to even out. Oil level should be 2” from top of tank for DUAL power units.

HYDRAULIC LINES - GRAVITY DOWN (Cont.)

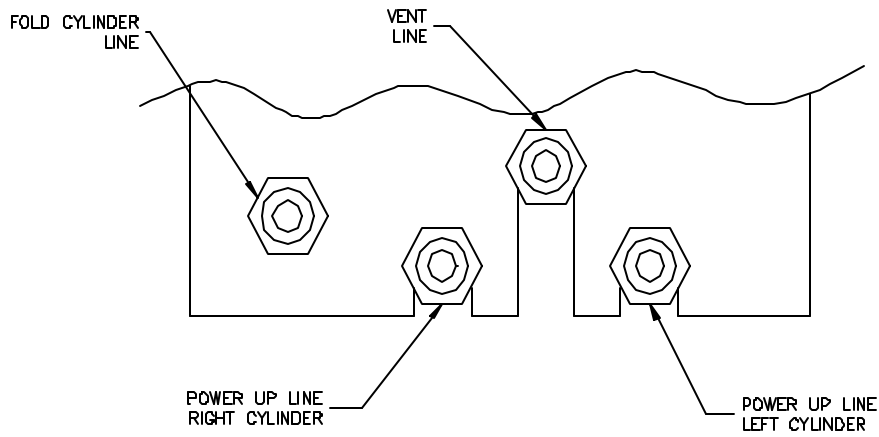

BOTTOM OF LEFT OUTER MAST
VIEW FROM BACK OF THE GATE

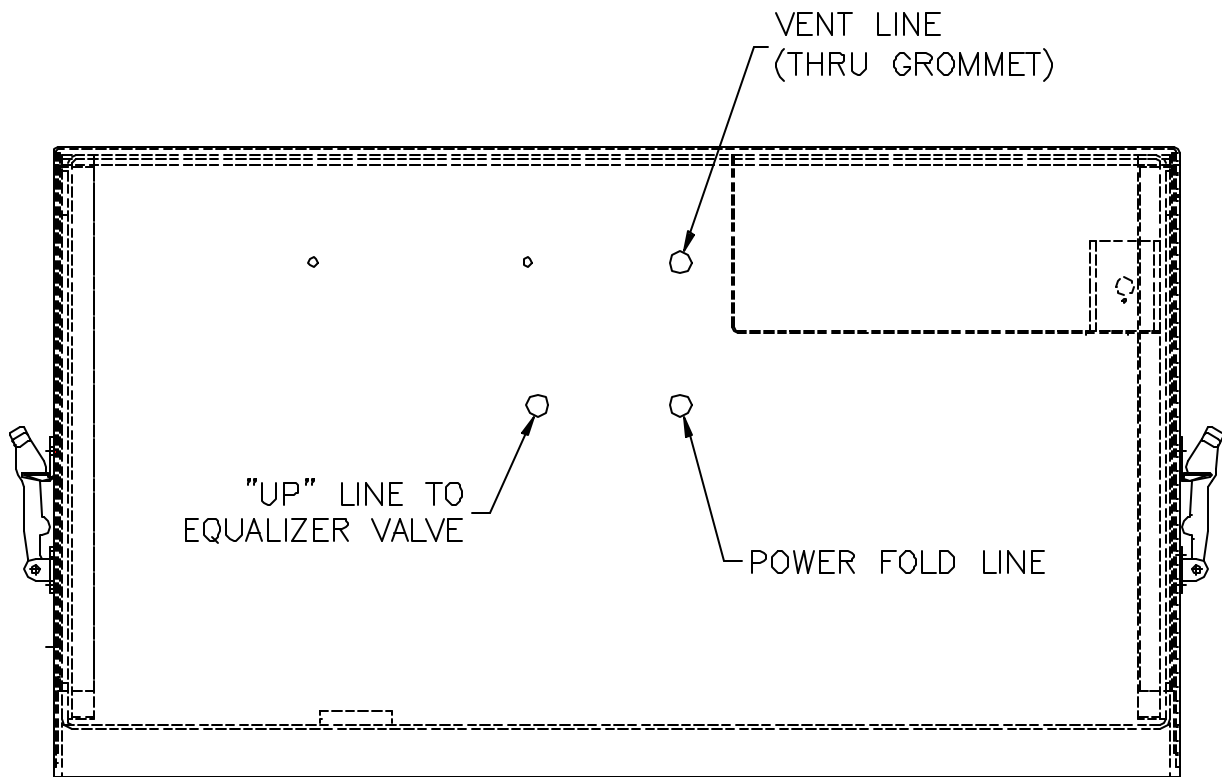

CONNECTIONS AT REAR OF POWER UNIT BOX

HYDRAULIC LINES – POWER DOWN

Up Line: First fill both tanks with a recommended hydraulic oil to within 2” from the top. Then connect one of the hydraulic lines to one of the exit ports of the equalizer valve behind the power unit. Take the second up/down line and connect it to the other exit port. Run both lines back to the gate. **Before connecting to bulkhead elbows on gate, run the power unit to fill the lines with oil.** Next, remove the caps on the bulkhead elbows at the bottom of the left Outer Mast and connect the hydraulic lines. See sketch on next page for port identification. Elbow fittings are provided with the hose kits to route the hoses straight up from the rail gate mast to the vehicle cross-members, if desired. Now, attach the hydraulic lines to the “I” beams with the loom clamps and self-tapping screws that are provided in the lift gate kit.

Down Line: Connect the hydraulic line to the bulkhead fitting mounted at the back of the power unit box and run the “down” line back to the bulkhead elbow located at the bottom of the left Outer Mast. **Before connecting to the elbow, run the power unit to fill the hydraulic line with oil.** Next, remove the cap at the elbow and connect the hydraulic line. See sketch on next page for port identification. Now, attach the hydraulic line to the “I” beams with the loom clamps and self-tapping screws that are provided with the lift gate kit.

Power Fold Line: Connect the hydraulic line to bulkhead fitting mounted at the back of power unit box and run the line back to the bulkhead elbow at the bottom of the left Outer Mast. Make sure this elbow is the one connected to the hydraulic line that is hooked up to the folding cylinder. **Before connecting to the elbow, run the power unit to fill the line with oil.** Next, attach the hydraulic line to the “I” beams with the loom clamps and self-tapping screws provided with the lift gate kit.

NOTE:

This procedure should minimize the amount of air trapped in the fold cylinder or hydraulic line. If the gate does not raise and lower smoothly or unfold and fold smoothly, see the page on bleeding the cylinders.

Oil Level Check: Unfold the platform and run to the full up position and recheck the oil level in the power unit. Wait several minutes for the oil level in both tanks to even out. Add oil if necessary so the level is approximately 2” from top of tank for DUAL power units.

HYDRAULIC LINES – POWER DOWN (Cont.)

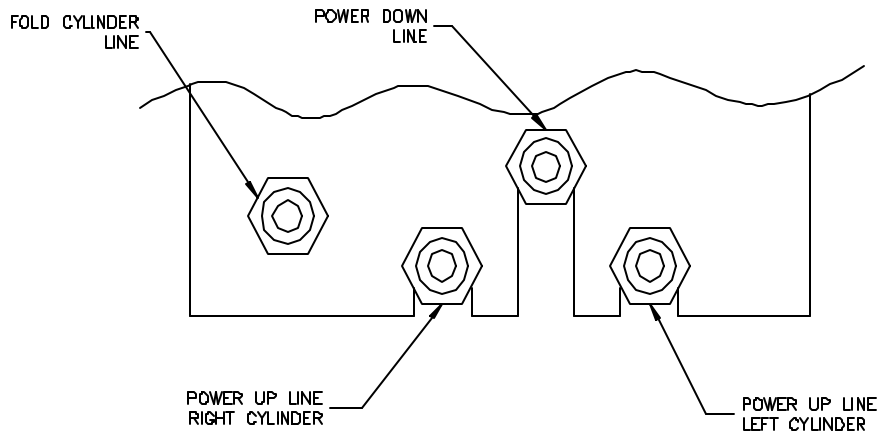

BOTTOM OF LEFT OUTER MAST
VIEW FROM BACK OF THE GATE

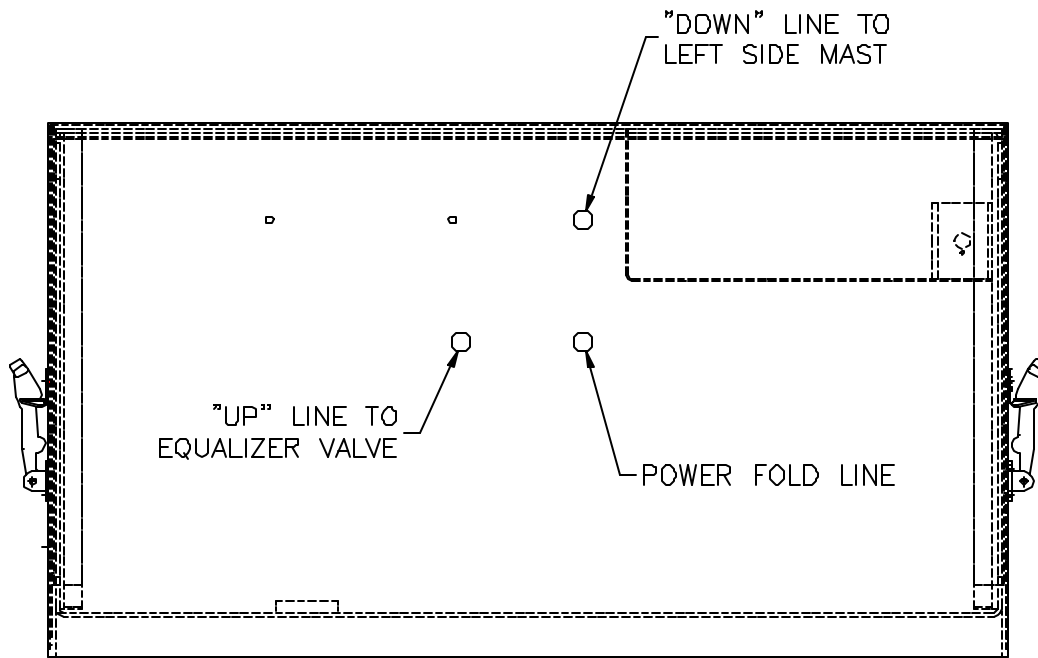

CONNECTIONS AT REAR OF POWER UNIT BOX

BLEEDING THE LIFT CYLINDERS - GRAVITY DOWN

The FXD[®] is shipped with the cylinders pre-filled with hydraulic fluid from the factory. *The cylinders must be bled before making any other adjustments.*

To Bleed the Lifting Cylinder – Bottom Side:

1. Unfold and lower the platform to the full down position. **CYLINDERS SHOULD BE EXTENDED TO THEIR FULL LENGTH (GATE EXTENDED DOWN 56") TO REMOVE AS MUCH AIR FROM THE BOTTOM SIDE OF THE CYLINDER AS POSSIBLE. DEPENDING ON THE FLOOR HEIGHT OF THE VEHICLE, IT MAY BE NECESSARY TO RAISE THE BODY OF THE VEHICLE OR LOWER THE GATE PLATFORM INTO A PIT TO ACHIEVE MAXIMUM CYLINDER EXTENSION.**
2. Loosen the plugs in the back ports (ports closest to the vehicle body), but do not remove completely.
3. Activate the pump just long enough to produce an air-free stream of oil from the ports.
4. Re-tighten the plugs in the ports, lower the platform to the full down position, and check the oil level in the reservoir tank. The oil level should be approximately 2" from top of the tank for DUAL power units.

To Bleed the Lifting Cylinders – Top Side

1. Not applicable on gravity down.

NOTE: FOR GRAVITY DOWN GATES, OIL LEVEL SHOULD ALWAYS BE CHECKED WITH THE PLATFORM UNFOLDED AND ALL THE WAY DOWN.

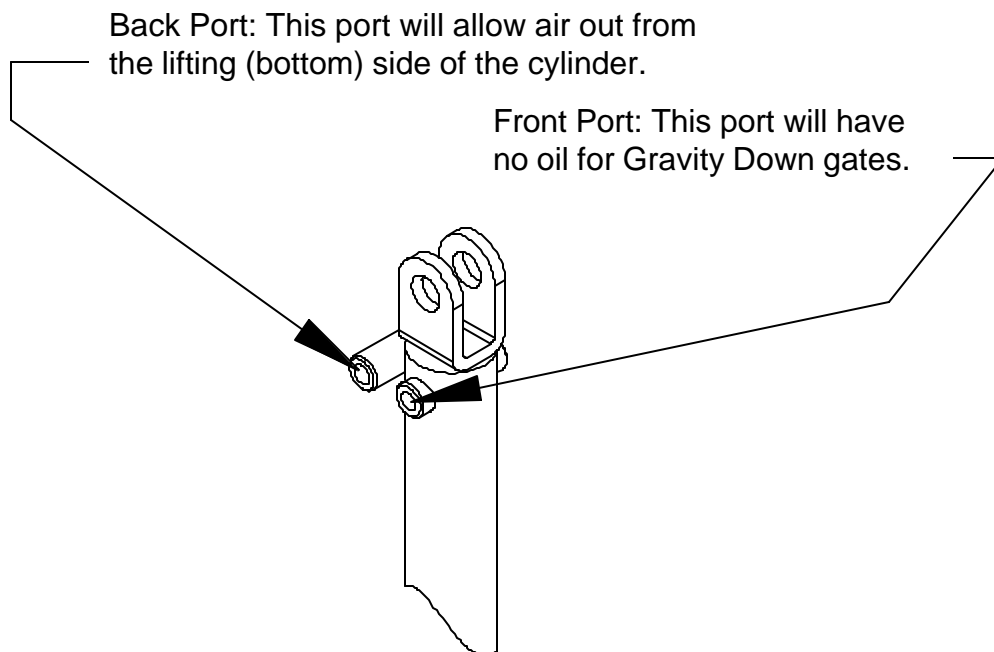

BLEEDING THE LIFT CYLINDERS – POWER DOWN

The FXD[®] is shipped with the cylinders pre-filled with hydraulic fluid from the factory. *The cylinders must be bled before making any other adjustments.*

To Bleed the Lifting Cylinder – Bottom Side:

1. Unfold and lower the platform to the full down position. **CYLINDERS SHOULD BE EXTENDED TO THEIR FULL LENGTH (GATE EXTENDED DOWN 56") TO REMOVE AS MUCH AIR FROM THE BOTTOM SIDE OF THE CYLINDER AS POSSIBLE. DEPENDING ON THE FLOOR HEIGHT OF THE VEHICLE, IT MAY BE NECESSARY TO RAISE THE BODY OF THE VEHICLE OR LOWER THE GATE PLATFORM INTO A PIT TO ACHIEVE MAXIMUM CYLINDER EXTENSION.**
2. Loosen the plugs in the back ports (ports closest to the vehicle body), but do not remove completely.
3. Activate the pump just long enough to produce an air-free stream of oil from the ports.
4. Re-tighten the plugs in the ports, raise the platform to the full up position, and check the oil level in the reservoir tank. The oil level should be approximately 2" from top of the tank for DUAL power units.

To Bleed the Lifting Cylinders – Top Side

1. Unfold and raise the platform to the full up position to remove as much air from the top side of the cylinder as possible.
2. Loosen the plugs in the front ports (ports furthest from the vehicle body) but do not remove completely.
3. Activate the pump (DOWN) just long enough to produce an air-free stream of oil from the ports.
4. Retighten the plugs in the ports, raise the platform to the full up position if not already there, and check the oil level in the reservoir tank. The oil level should be approximately 2" from top of the tank for DUAL power units.

NOTE: FOR POWER DOWN GATES, OIL LEVEL SHOULD ALWAYS BE CHECKED WITH THE PLATFORM UNFOLDED AND RAISED ALL THE WAY UP.

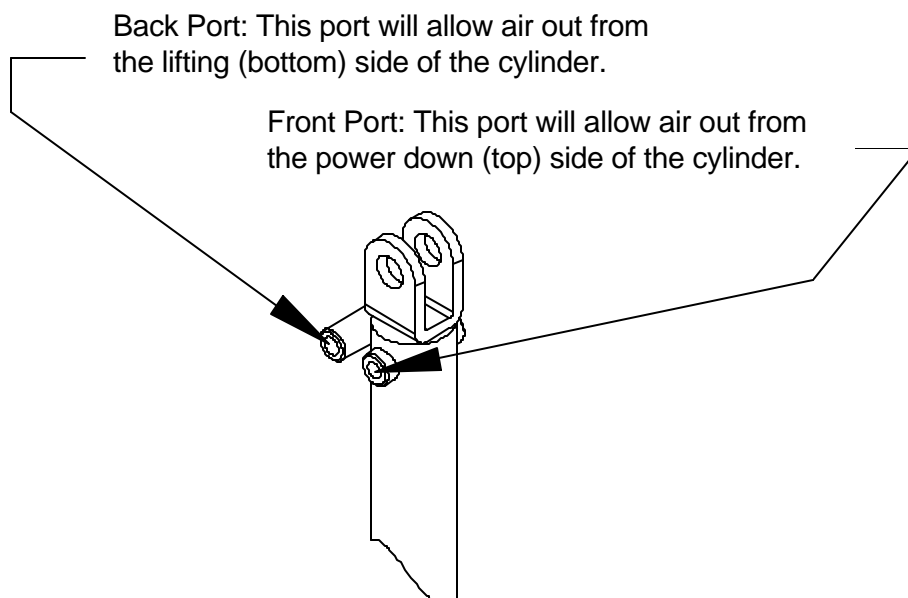

TO BLEED THE POWER FOLD CYLINDER

1. Unfold and lower the platform down to the ground.
2. Loosen the hose at the cylinder but do not remove completely.
3. Activate the pump just long enough to product an air free stream of oil from the hose.
4. Re-tighten the hose and check the oil level in the reservoir tank. Note: hold line while tightening to ensure it does not twist.
5. Fold and unfold the platform several times. The platform should now fold and unfold smoothly.

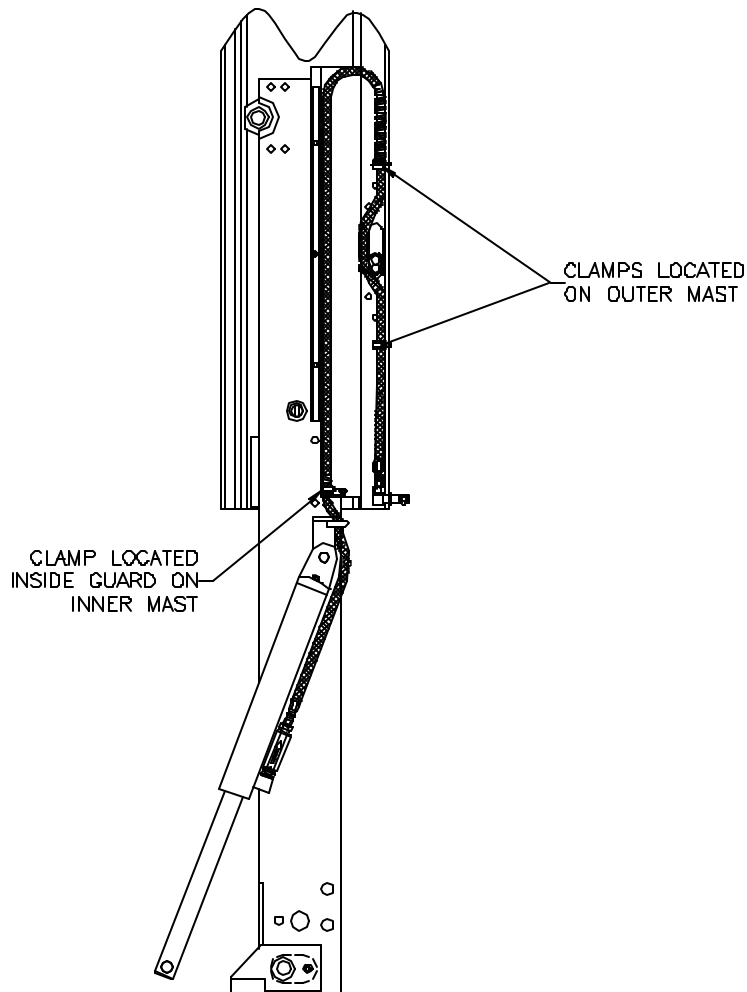

CHECK OIL LEVEL AFTER BLEEDING THE CYLINDER:

GRAVITY DOWN GATES – Check with platform unfolded and on ground.

POWER DOWN GATES – Check with platform unfolded and up at bed height.

CONNECTING STOP / TAIL / TURN LIGHTS

FXD® gates are supplied with LED Stop / Tail / Turn lights as standard. The LED lights are normally shipped loose to avoid damage during shipping and gate installation. 16-4 light cable has been run through each Outer Mast at the factory. The standard LED lights should be mounted and connected as follows:

TOP LIGHTS are for TAIL /TURN – leads on lights

WHITE = ground
BROWN = tail light
GREEN = turn light

BOTTOM LIGHTS are for TAIL / STOP – leads on lights

WHITE = ground
BROWN = tail light
GREEN = stop light

It is recommended that the 16-4 cables supplied and pre-installed in the Outer Masts be connected as follows:

16-4 cable in right-hand (curb side) mast-

RED = stop light
BROWN = tail light
GREEN = RH turn
YELLOW = ground

16-4 cable in left -hand (driver's side) mast-

RED = stop light
BROWN = tail light
YELLOW = LH turn
GREEN = ground

Use butt connectors with heat shrink to connect lights to the 16-4 cables. Install oval lights using grommets supplied. At the opposite end of the 16-4 cables, cut to required length and make connections to the main light harness by re-using the light plugs for the trailer lights that the lift gate has covered, or partially covered, and will not be used. Do NOT cut or splice into main trailer light harness. Attach the re-used plugs to the 16-4 cables using butt connectors with heat shrink. The ground wire in a standard trailer light cable is usually WHITE. On the curb side match the RED, BROWN, and GREEN wires. Then connect the YELLOW on the 16-4 light cable with WHITE on the trailer light harness. On the driver's side, match the RED, BROWN, and YELLOW wires. Then connect the GREEN wire on the 16-4 light cable with the WHITE on the trailer light harness.

PAINTING THE VEHICLE

The adhesion of any paint to any surface depends first and foremost on whether the surface is clean, both physically and chemically. **It is critical that all cylinder rods are protected during the painting process.**

FXD[®] rail gates are painted with Leyman Extreme Shield[®] at the factory and must be touched up using the Extreme Shield[®] kit provided. Follow directions on the label.

Painting

Leyman Extreme Shield[®] can be top coated with alkyds, epoxies, or urethanes, if it is desired to top coat the entire lift gate.

Basic Steps

1. While the vehicle is located in the shop area, perform all preparation to the surface, to include any grinding, etc.
2. Using dry rags, remove all excess dirt, grease, and hydraulic fluid from all metal surfaces that will be painted. Take special care not to create larger problems by spreading the excess on any related surfaces.
3. Using a wax and grease remover, clean all heavily greased areas of dirt, hydraulic oil or any other substances from all metal surfaces that are to be painted. This will not only help clean the surface, but allow the metal prep steps do their job better.

NOTE: Remember that using any removers and metal prep, paint, etc. can be dangerous. Be sure that all directions are followed carefully when using these products.

Metal Preparation:

Using the correct equipment, start the metal preparation operation on the surfaces to be painted.

1. Use a metal preparation brush saturated and diluted with “granodine” to scrub all the areas. Follow all safety requirements listed on the material being used.
2. Rinse the surface clean. An unbroken sheet with all the foam rinsed off will indicate a surface is properly prepared and ready for the “galvaprep” application. The surface does not need to be dry to apply the “galvaprep”.
3. Metal preparation material reduction is 3 to 1. Apply to surface from the bottom to the top, before the roof. Remember to keep the surface wet.
4. Using the applicator, apply the “galvaprep” to the desired surfaces (reduction is 3 to 1), starting from the bottom, to the top and over the roof. Rinse at room temperature with fresh water.

NOTE: Follow any and all safety requirements as listed on the material being used.

5. Using a clean air supply, blow dry all seams, joints and crevices. Wipe dry any moisture splatters that appear and clean with dry rags.
6. After processing and drying thoroughly, the surface is ready to be painted.

Mask and protect all surfaces not being painted. Remember to read and follow all safety requirements for materials that you use.

INSTALLATION OF WARNING SIGNS / DECALS

STREET SIDE DECALS

Warning Signs and Decals will be replaced at any time
FREE OF CHARGE

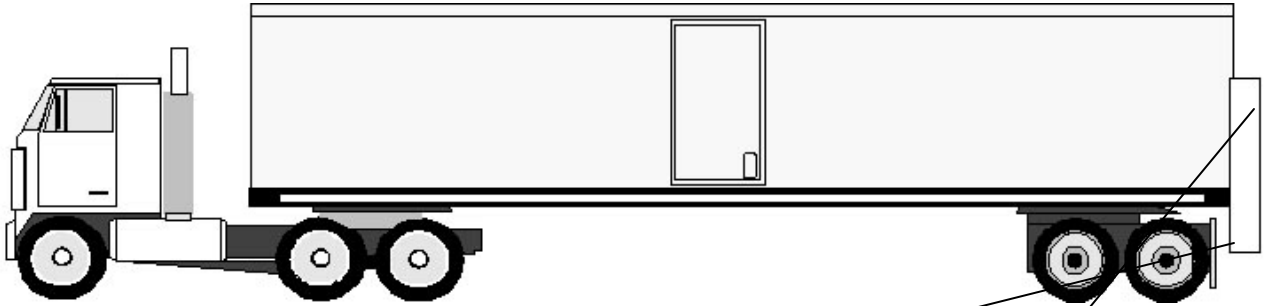

Will receive two of these decals. One goes on each side at bottom of Outer Mast



INSTALLATION OF WARNING SIGNS / DECALS

CURB SIDE DECALS

Warning Signs and Decals will be replaced at any time
FREE OF CHARGE

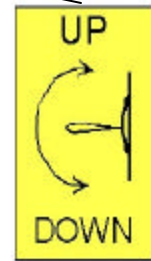
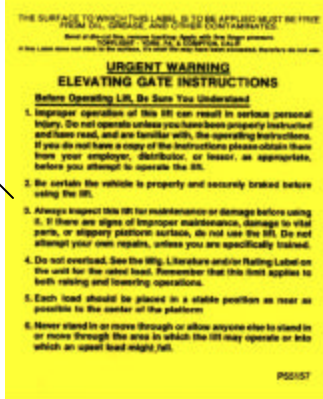
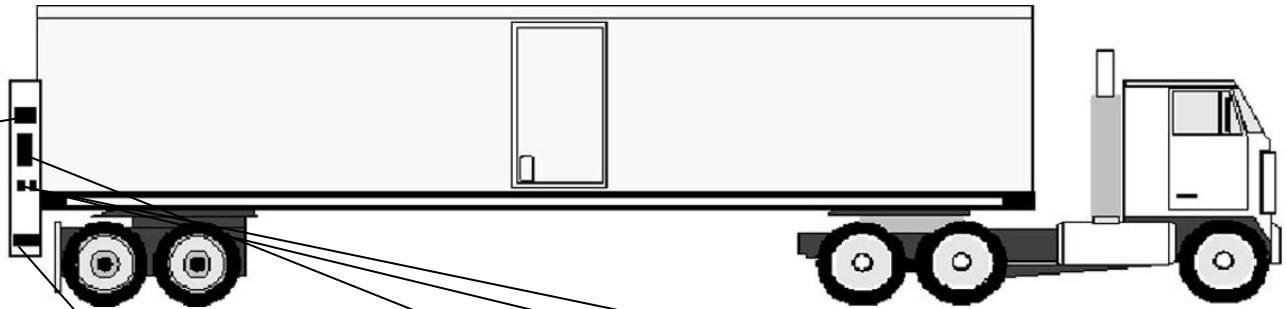

Mount each decal next to the corresponding toggle switch. Make sure you mount three UP / DOWN decals (two on the inside of the Outer Mast). Mount two FOLD / UNFOLD decals (next to the dual switch plate).

Mount one Max. Cap. decal on outside of Outer Mast near switches. Mount other Max. Cap. decal on Inner Mast just above chain anchor.

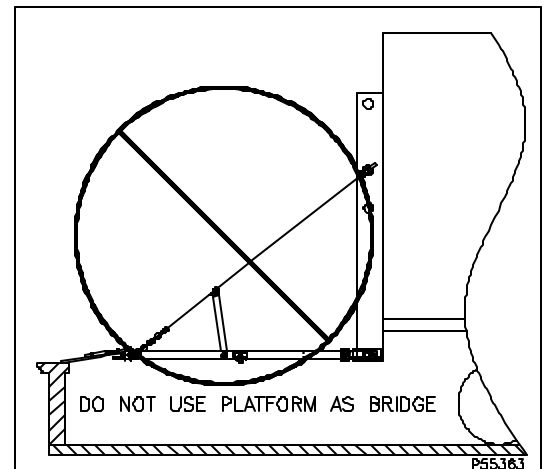
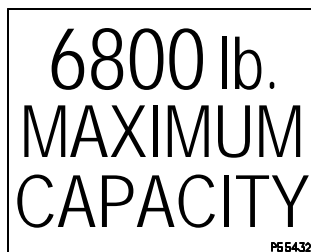

INSTALLATION OF WARNING SIGNS / DECALS

REAR OF VEHICLE DECALS

Warning Signs and Decals will be replaced at any time
FREE OF CHARGE

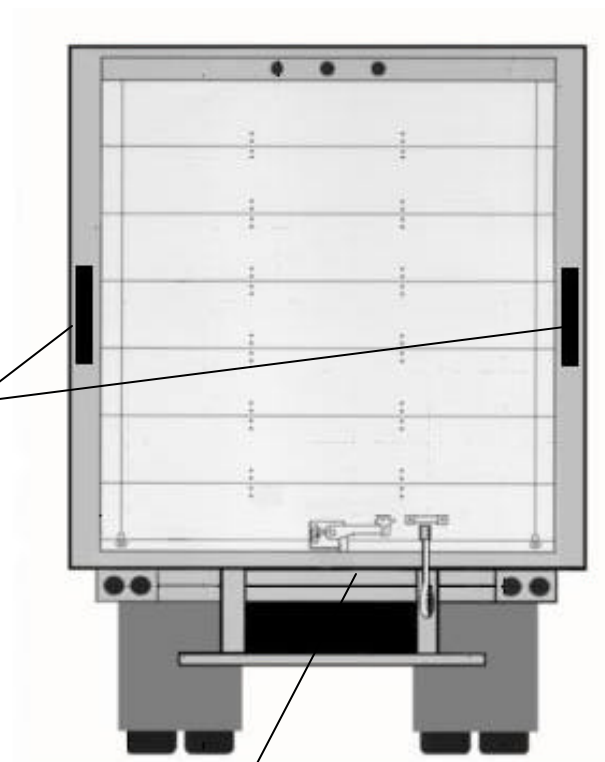

Will receive two of these decals
One goes on each side of the Outer Mast

CAUTION KEEP FEET FROM EDGE OF PLATFORM

MODEL AND SERIAL NUMBER TAGS

Serial No. is also located in MENU 1 of Maintenance Minder 2[®]

Serial number tag is located inside power unit box.

	
10900 KENWOOD ROAD CINCINNATI, OHIO 45242 513-891-6210 WWW.LEYMANLIFT.COM	
MODEL	FXD68PDD-8684RR
SERIAL NO.	289999
CAPACITY	6800 lbs.
MANUFACTURE DATE	08-14-08

Model number tag is located on the left-hand Outer Mast.

	
10900 KENWOOD ROAD CINCINNATI, OHIO 45242 513-891-6210 WWW.LEYMANLIFT.COM	
MODEL	FXD68PDD-8684RR
CAPACITY	6800 lbs.
MANUFACTURE DATE	08-14-08
PATENTS PENDING	

FINAL INSTALLATION INSPECTION

CUSTOMER:		
LOCATION:	UNIT # / VIN #	
VEHICLE#:	LIFT GATE MODEL#:	LIFT GATE SERIAL#:

Ö=OK(INITIAL)

N = NOT APPLICABLE

WELDING	
	Gate is welded secure to vehicle (2" long welds spaced 10" to 12" inside and outside both Outer Masts) at stainless steel mounting channels.
	Power pack box is welded to cross members using full length welds. If power pack is securely bolted instead, then ground cable is installed.
	Header Kit (dock seal) is securely riveted to vehicle.
ELECTRIC'S	
	Check that battery holds downs are tightened securely, and rubber pads are installed under batteries.
	Check battery (ies) for proper charge level. PROPER CHARGE LEVEL:
	Check all wiring connections for tightness (batteries, switch cable, etc.)
	Inspect and check all circuit breakers
	Charge line/power line (through cross members with rubber grommets, or clamped using loom clamps).
	Electric line from gate to power pack (through cross members with rubber grommets, or clamped using loom clamps).
	Check operation of inside and outside toggle switches.
	Check operation of lights in Outer Mast
HYDRAULIC	
	Hydraulic lines from gate to power pack (through cross members with rubber grommets, or clamped using loom clamps).
	Hydraulic lines from gate to power pack – check for leaks by running each function at by -pass.
	Check reservoir for correct amount of fluid (platform should be open & down when checking)(up if power down),2" below top of tank. Let tanks even out.
	Bleed air from folding cylinder.
	Bleed air from lifting cylinders.
	Check fold and lift cylinders for leaks
	Dual Power Unit – Check operation of both power units. Also test Emergency Pushbutton unit. Then set to operate on primary unit (both Selector Switches left).
OPERATION OF GATE	
	Open and close lift gate. Observe for correct operation (use both power units, plus Emergency Control).
	Raise and lower lift gate. Observe for correct operation (use both power units, plus Emergency Control)
MISCELANEOUS	
	Rear Impact Guard extension installed to meet 12" dimension to primary gate structure. Add reflective tape
PAINTING AND SAFETY STICKERS	
	Repaint where needed
	Check hydraulic cylinder rods for over spray
	Install all safety and operation stickers

SERVICED BY: _____ DATE: _____

4/07

OPERATING THE LIFT GATE

Before operating the lift, read and understand this decal, Urgent Warning decal and Owner's manual.

Do not stand behind lift gate while unfolding or using platform.

To unfold the platform from over-the-road position

1. Toggle the DOWN switch to lower platform.
2. Lower the platform until arrow indicates FOLD / UNFOLD region. Toggle both UNFOLD switches. Gate will unfold.

To dock load

1. Toggle the DOWN switch to lower platform.
2. Continue lowering until platform rests on dock level stops.

WARNING! Never use the platform as a “bridge” to a dock or other vehicle. Platform can fold unexpectedly and cause injury.

To lower platform, use the down switch only.

To raise platform, use the up switch only.

Safe loading of platform

1. Cart stop or retention ramp must be in place whenever lifting or lowering a load. Also, see the Urgent Warning decal.

To fold platform

1. Raise the platform until arrow indicates FOLD / UNFOLD region. Then toggle both FOLD switches until platform completely folds. Raise platform until gate hits Up Stops and arrow indicates locked position. Do not move vehicle unless gate is in locked position.

ELECTRICAL DIAGRAM DUAL GRAVITY DOWN

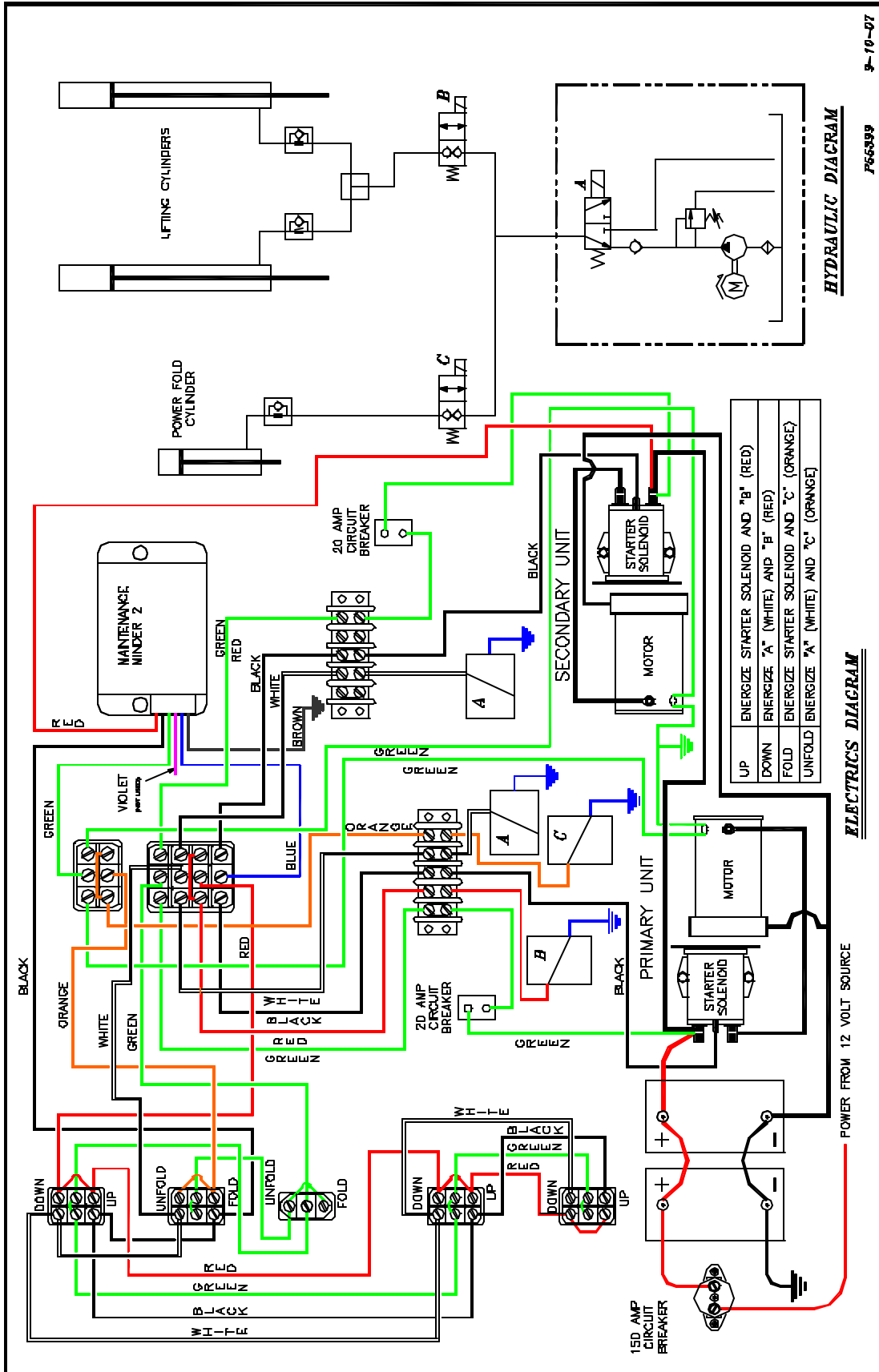

WALK AROUND ELECTRICS GRAV. DOWN (Opt.)

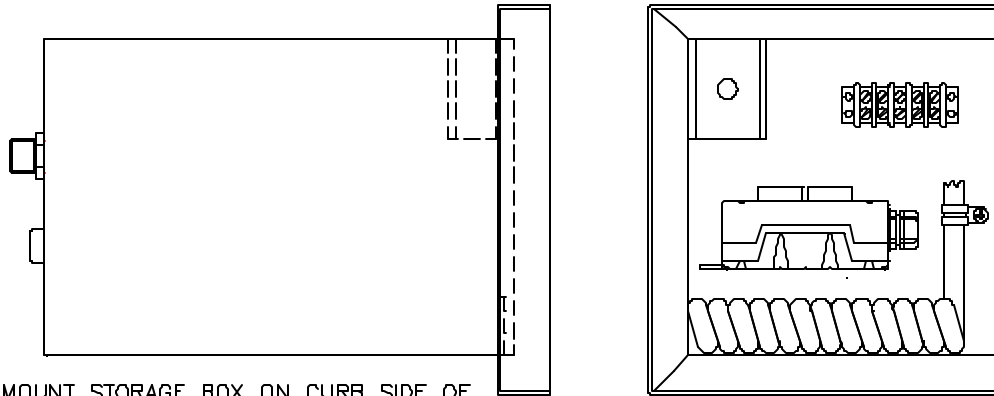

MOUNT STORAGE BOX ON CURB SIDE OF VEHICLE. ROUTE 16-5 CABLE TO POWER UNIT BOX.

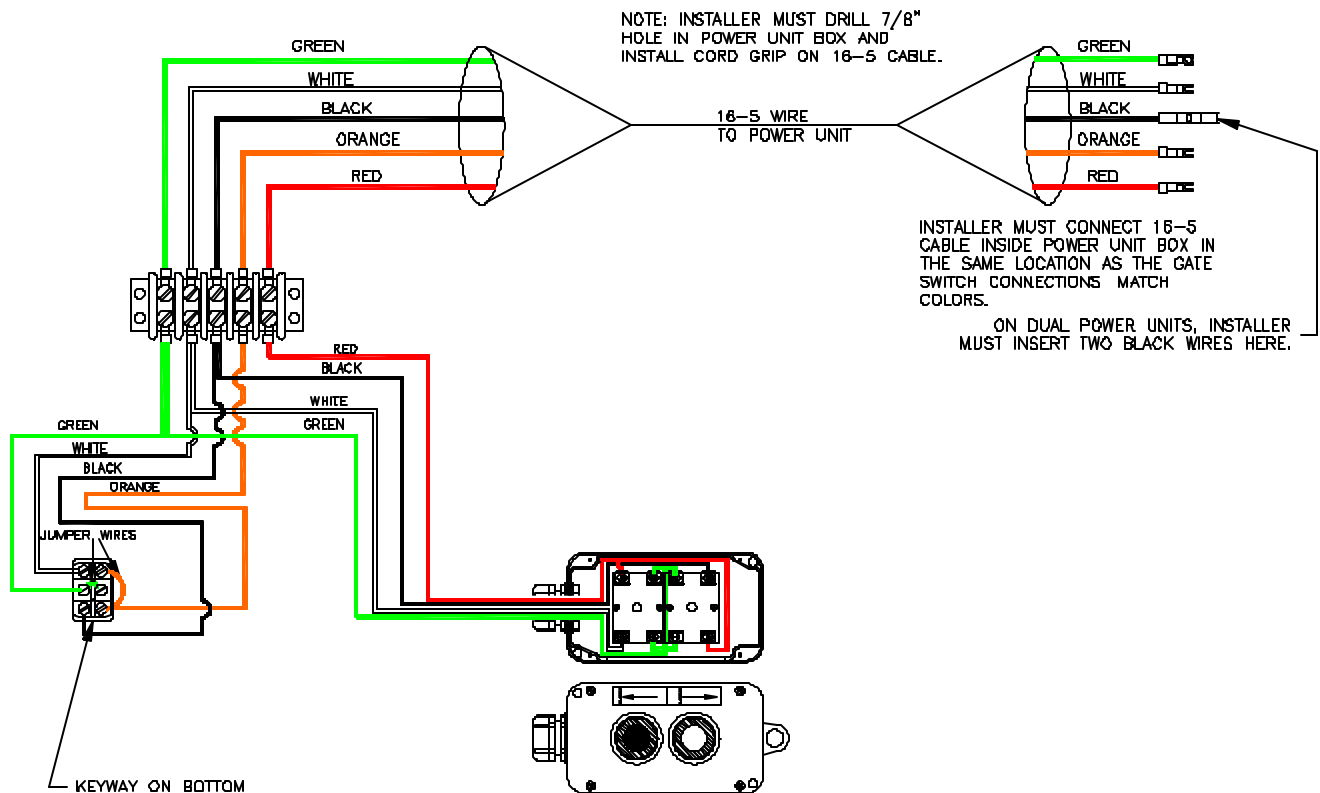

WALK AROUND ELECTRICS POWER DOWN (Opt.)

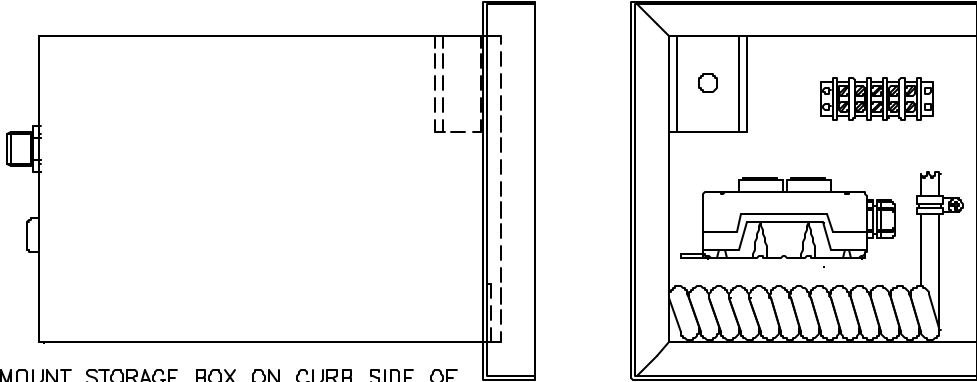

MOUNT STORAGE BOX ON CURB SIDE OF VEHICLE. ROUTE 16-5 CABLE TO POWER UNIT BOX.

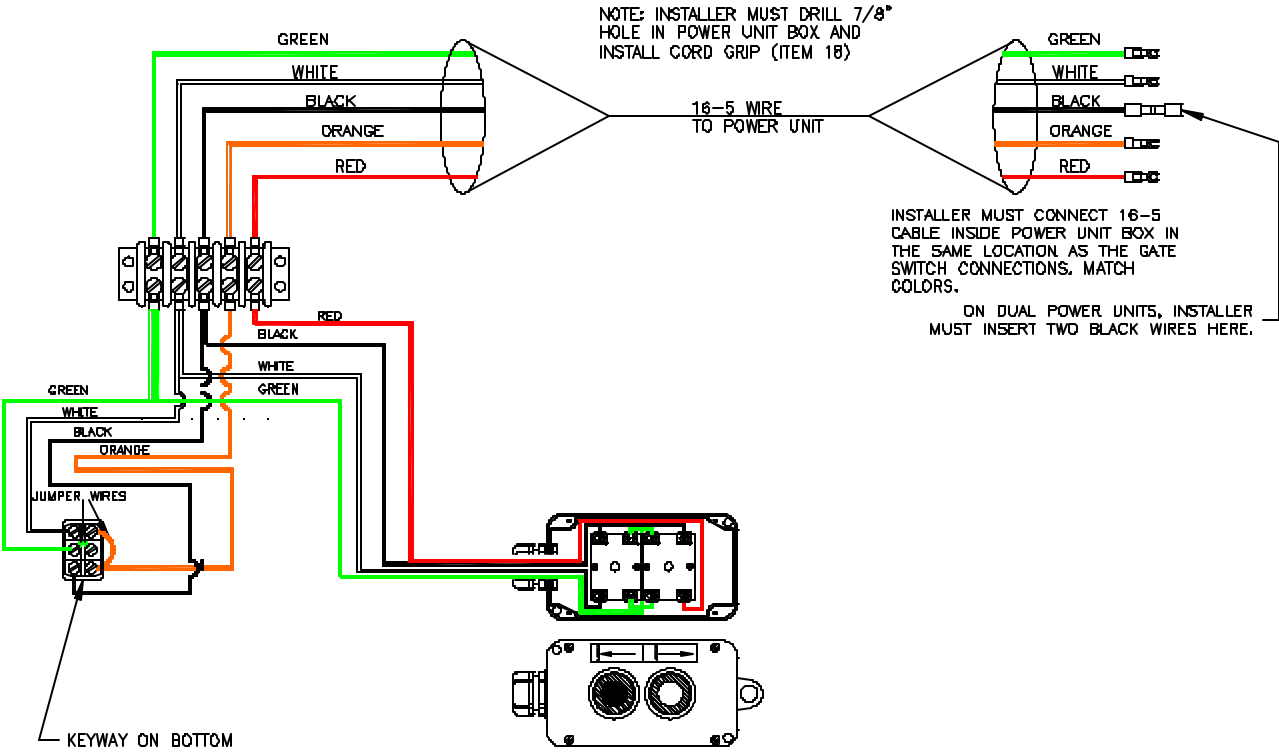

MAINTENANCE MINDER 2[®] OVERVIEW

Power unit is equipped with the Maintenance Minder 2[®] Controller. It will:

- Automatically keep track of maintenance intervals and warn the user when maintenance is due, based on the number of lifts.
- Record low voltage occurrences.
- Record of high temperature faults.
- Record of maximum run time faults, when a single operation exceeded the maximum continuous run time limit.
- Give helpful trouble-shooting information on MENU 4, “Last Lift Info”.

FAULTS CODES

A decal in the power unit enclosure lists the following signal codes for these faults:

1 BEEP	Service Fault (reached the number of lifts when maintenance is due)
2 BEEPS	Low Voltage Fault (check battery condition and power line connections)
3 BEEPS	Max. Time Fault (exceeded the maximum continuous run time allowed)
4 BEEPS	High Temperature Fault (unit will not run until motor cools)

All faults signals will be repeated FOUR times, except the Service Fault signal. Controller will prevent power unit from operating during the time period when a fault signal is sounding (about 5 to 10 sec.) except for the Service Fault signal. The controller is also equipped with an anti-doorbelling feature, which prevents rapid ON/OFF operation of the power unit.

RESETTING after MAINTENANCE IS PERFORMED

To RESET the Maintenance Minder 2[®] after maintenance has been performed:

1. Go to MENU 2, hit “ENTER”, and toggle down to the “Reset All Info” screen.
2. Press and hold the hidden RESET button under Maintenance Minder 2[®] logo at top of faceplate.
3. Follow the instructions on the screen regarding a second button, which must be pressed to complete the reset operation.



MAINTENANCE MINDER 2[®] CONTROLLER

MENUS

(Press MENU)

MENU 1 – LIFT GATE INFO

(Press ENTER, then ARROW DOWN for each item)

Model Number, Serial Number, Manufacture Date, Vehicle ID, Hardware Version, Firmware Version, Software Version.



(Press MENU and ARROW DOWN once)

MENU 2 – PERIOD INFO (data for current maintenance period)

(Press ENTER, then ARROW DOWN for each item)

Number of Lifts (gives the number during this maintenance interval and the set number when maintenance is due)

Motor ON (total motor run time in minutes for this maintenance period)

Service Fault (number of times gate was operated PAST the maintenance limit)

Max. Time Faults (times motor exceeded its maximum allowable continuous run time)

High Temperature Faults (times thermal switch in motor tripped, if switch provided)

Low Voltage Faults (times low voltage occurred)

Reset all Info (Reset data after performing maintenance, once maintenance limit is reached – see reset instructions on previous page)



MAINTENANCE MINDER 2[®] CONTROLLER

MENUS

(Press **MENU** and **ARROW DOWN** twice)

MENU 3 – LIFE TIME INFO (data for the total life time of the gate)

(Press **ENTER**, then **ARROW DOWN** for each item)

Same items will appear as under PERIOD INFO, except this is LIFE TIME data.

Reset History (reviews history for each maintenance interval)

Press **ENTER**, then **ARROW DOWN** to show history. Most recent period is the highest #. Screen shows Period #, # of Lifts, and Total Run Time in minutes.



(Press **MENU** and **ARROW DOWN** three times)

MENU 4 – LAST LIFT INFO (Trouble Shooting Screen – it records data that occurred during the last lift made)

(Press **ENTER**, then **ARROW DOWN** for each item)

Supply Voltage (first voltage is the minimum voltage that occurred during the last lift – if below 6 volts gate will stop / second voltage is the supply voltage just before gate operation, must be at least 10 volts).

Motor ON (motor run time in seconds during last lift, gate will stop at 180 seconds).

Window Time (time in milliseconds during the last lift that the voltage dropped in between 6 and 8 volts – must not be any longer than 3 seconds or gate will stop).



NOTE:

Controller has an anti-doorbelling feature. Motor will not operate if UP switch is toggled rapidly. This prevents welding of the start solenoid contacts.

