

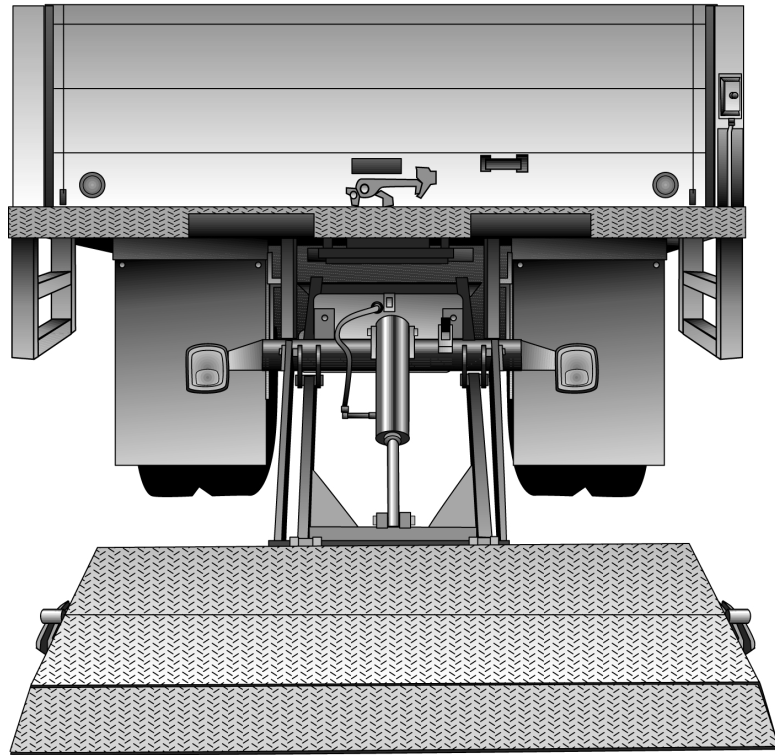

Installation Manual

LHS & LLBS Hide-A-Way™ Tuckunder Style



10900 Kenwood Road • Cincinnati, OH 45242

Ph: 513-891-6210 • Toll-Free: 866-539-6261

Fax: 513-891-4901

www.leymanlift.com • sales@leymanlift.com

LML00136-10/29/08

TABLE OF CONTENTS

Words of Caution	3
Operation of the Lift Gate	4
General View “Truck Mounting”	5
LHS2500 Truck Preparation	6
LLBS2500 Truck Preparation	7
LHS1600 Truck Preparation	8
Notch Rear Sill and Weld Extension to Rear Sill	9
Cut off Mounting Brackets and Mounting Gate Illustration	10
Mounting Gate Steps	11-12
5-13 Illustration “A” & 5-14 Illustration “B”	12
5-15 Illustration “C” & 5-16 Illustration “D”	13
5-17 Illustration “F” – Recommendations	14
Trouble Shooting Chart LHS & LLBS	15
Electrical Diagram	16
Installing Safety Decals	17
Final Inspection	18
Notes	19

WORDS OF CAUTION

1. Before any maintenance is performed on this unit, read and understand this manual completely.
2. Do not stand on or behind the platform when operating gate in the folded position.
3. Make sure the ground is clear under the platform when lowering.
4. Do not stand in front of platform when lowering from vertical position or operating in any manner.
5. Never exceed the rated load capacity of this gate.
6. Do not allow persons to operate the unit unless they have been properly trained to do so.
7. Use only factory authorized parts for replacement.
8. Check the area around the unit for persons before operating the lift gate.
9. This lift gate should operate smoothly and the only noise that should be heard is the power unit. Any audible sounds other than the normal power unit operation sound should be thoroughly inspected and the cause of the noise should be pinpointed and corrected.
10. Do not over load – the maximum rated capacity is based on an evenly distributed load all over the platforms flat surface.
11. Always load as close to the center of the platform and as close to the center of the truck sill as possible.
12. 150 Amp circuit breaker (not supplied) must be installed between the starter solenoid and the battery source.
Order from factory as option #111-Circuit Breaker.

We urge the installation of a safety cut-off switch for all truck mounted lift gates. These are installed in the cab of the vehicle, so the power to the lift gate can be turned on/off.

This manual reflects most changes and updates of materials that are common to this type of lift gate. Some may differ due to individual customer requirements. This manual has been established to reflect the common items.

WARNING: Since this gate has greaseless bearings in the main pivot points, (tension and compression arms or platform parts) any welding on these parts must be grounded or you will damage the cylinder.

OPERATING OF THE LIFT GATE

- Before operating the lift, read and understand this decal, urgent warning decal, and the Owner's Manual.
- Do not stand behind the lift gate while unfolding or using the platform.

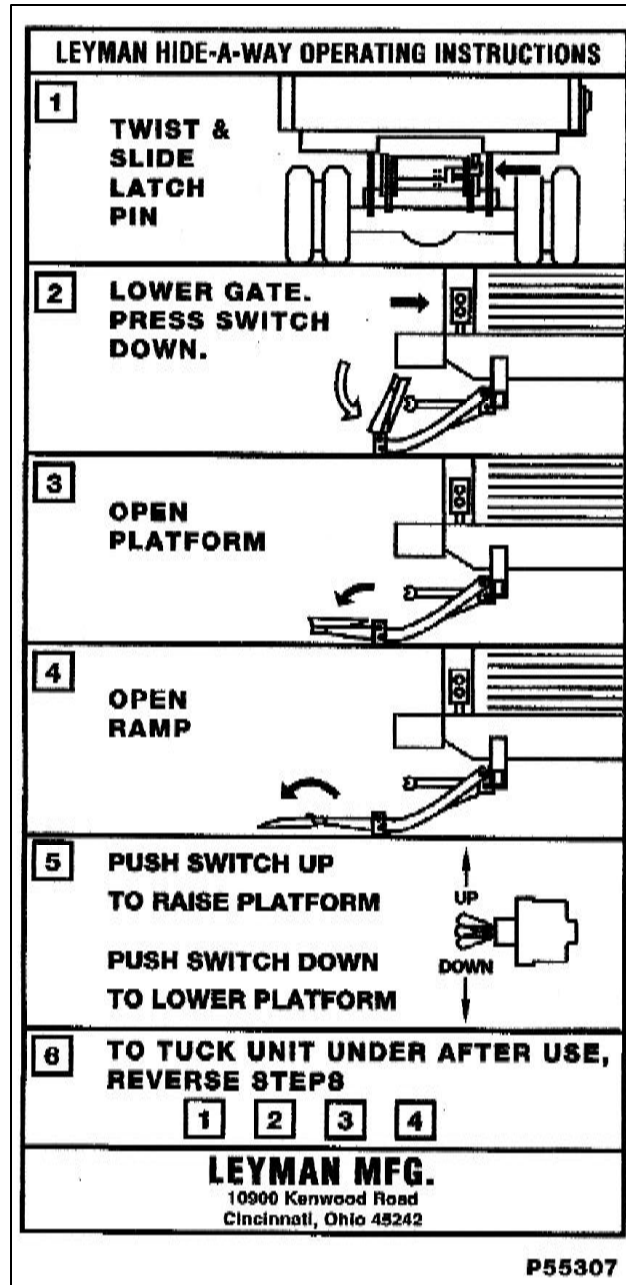

SEE MOUNTING DIMENSIONS ON NEXT PAGE

GENERAL VIEW TRUCK MOUNTING

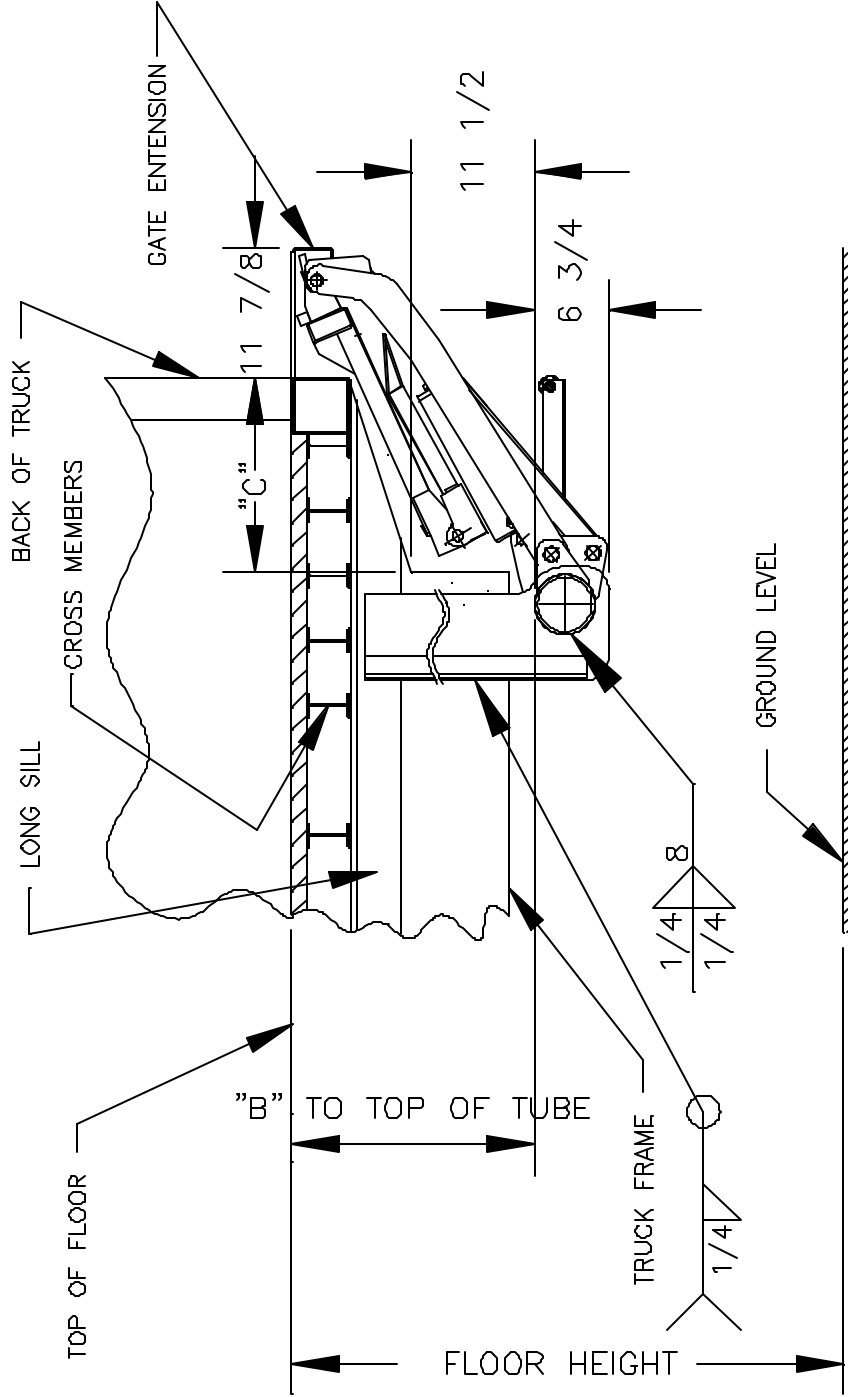

CAUTION! Mounting Plates to Lift Gate Frame Tube must be welded on BOTH sides. Continuous weld required on outside faces. 8" long weld (half way around) required on inside faces.

LHS2500 TRUCK PREPARATION

See Chart for Mounting Dimension

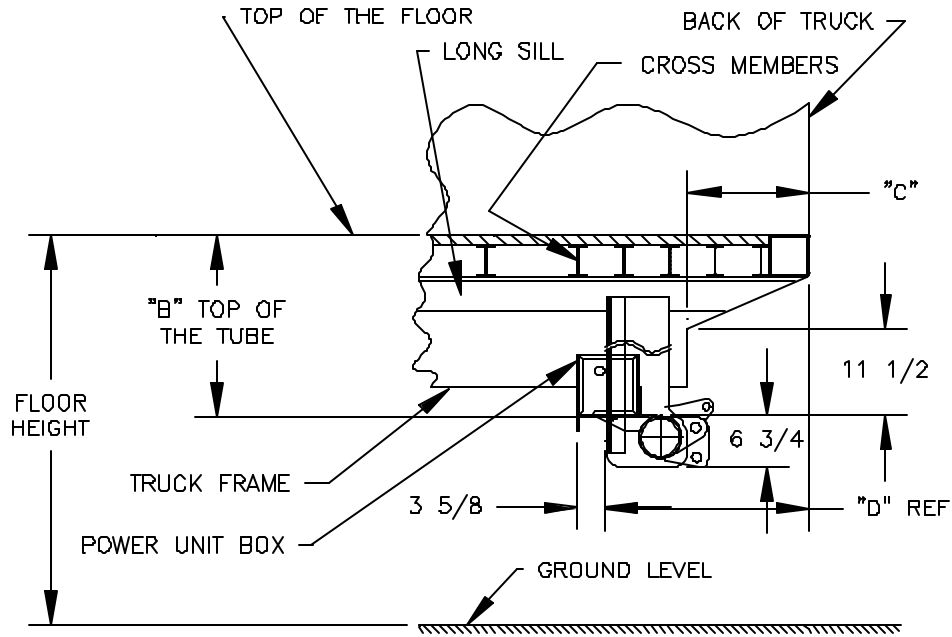

LHS2500 Mounting Dimension Chart

Floor Height	"B"	"C"	"D" REF.	"E" MAX.
42	22-1/2 in	19-1/2 in	28-5/8 in	4-1/4 in
43	22-1/2 in	19-1/2 in	28-5/8 in	4-1/4 in
44	22-1/2 in	19-1/2 in	28-5/8 in	4-1/4 in
45	22-1/2 in	19-1/2 in	28-5/8 in	4-1/4 in
46	23-11/16 in	18 in	26-3/4 in	4-1/4 in
47	23-11/16 in	18 in	26-3/4 in	4-1/4 in
48	23-11/16 in	18 in	26-3/4 in	4-1/4 in
49	23-11/16 in	18 in	26-3/4 in	4-1/4 in
50	23-11/16 in	18 in	26-3/4 in	5-1/8 in
51	23-11/16 in	18 in	26-3/4 in	5-1/8 in
52	24-11/16 in	17-5/8 in	26-1/4 in	5-3/4 in
53	24-11/16 in	17-5/8 in	26-1/4 in	5-3/4 in
54	24-3/16 in	17-5/8 in	26-1/4 in	6-1/4 in
55	25-5/16 in	16 in	25 in	6-1/4 in
56	26-5/8 in	15 in	23-7/16 in	6-1/4 in

NOTE: ADD 3-5/8 IN TO DIM "D" FOR OVER ALL LENGTH
NOTE: MAX./MIN. SPREAD OF GATE MOUNTING PLATES
 37" MAXIMUM to 31.5" MINIMUM

LLBS2500 TRUCK PREPARATION

See Chart for Mounting Dimension

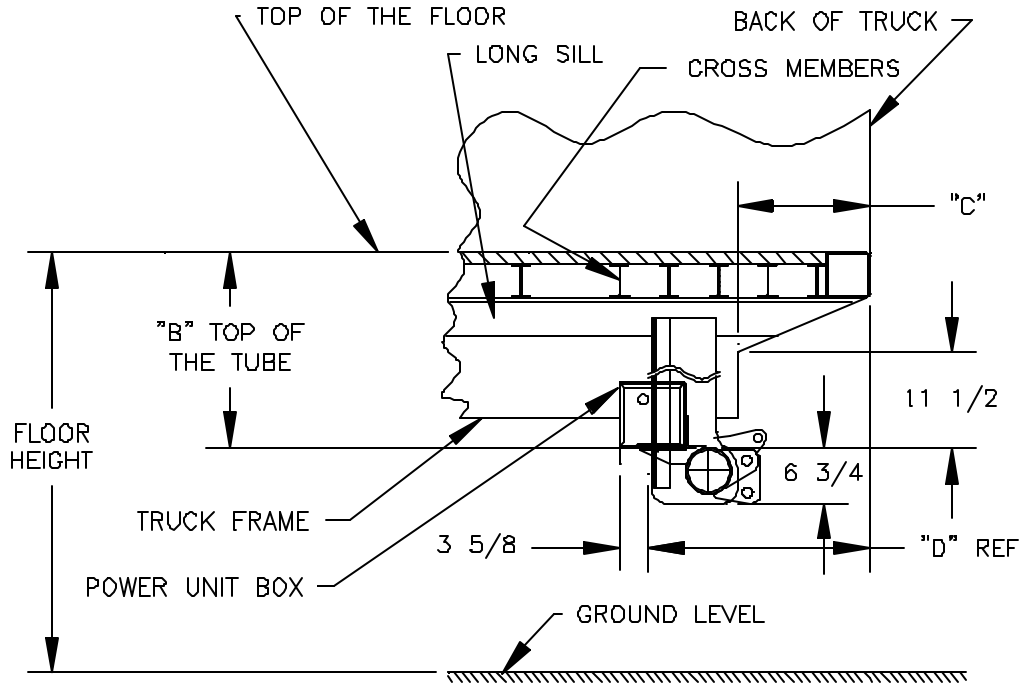

LLBS2500 Mounting Dimension Chart

Floor Height	"B"	"C"	"D" REF.	"E" MAX.
36	15-1/2 in	24 in	32-3/4 in	4-1/4 in
37	15-1/2 in	24 in	32-3/4 in	4-1/4 in
38	18-1/2 in	22 in	31 in	4-1/4 in
39	18-1/2 in	22 in	31 in	4-1/4 in
40	18-1/2 in	22 in	31 in	4-1/4 in
41	19 in	21-3/16 in	30-5/8 in	4-1/4 in
42	19 in	21-3/16 in	30-5/8 in	4-1/4 in
43	20 in	20-11/16 in	29-7/8 in	4-1/4 in
44	20 in	20-11/16 in	29-7/8 in	4-1/4 in
45	24-3/4 in	16-1/2 in	25-1/2 in	4-1/4 in
46	24-3/4 in	16-1/2 in	25-1/2 in	4-1/4 in
47	24-3/4 in	16-1/2 in	25-1/2 in	4-1/4 in
48	23-11/16 in	18 in	26-3/4 in	4-1/4 in
49	23-11/16 in	18 in	26-3/4 in	4-1/4 in

NOTE: ADD 3-5/8 IN TO DIM "D" FOR OVER ALL LENGTH
NOTE: MAX./MIN. SPREAD OF GATE MOUNTING PLATES
 37" MAXIMUM to 31.5" MINIMUM

LHS1600 TRUCK PREPARATION

See Chart for Mounting Dimension

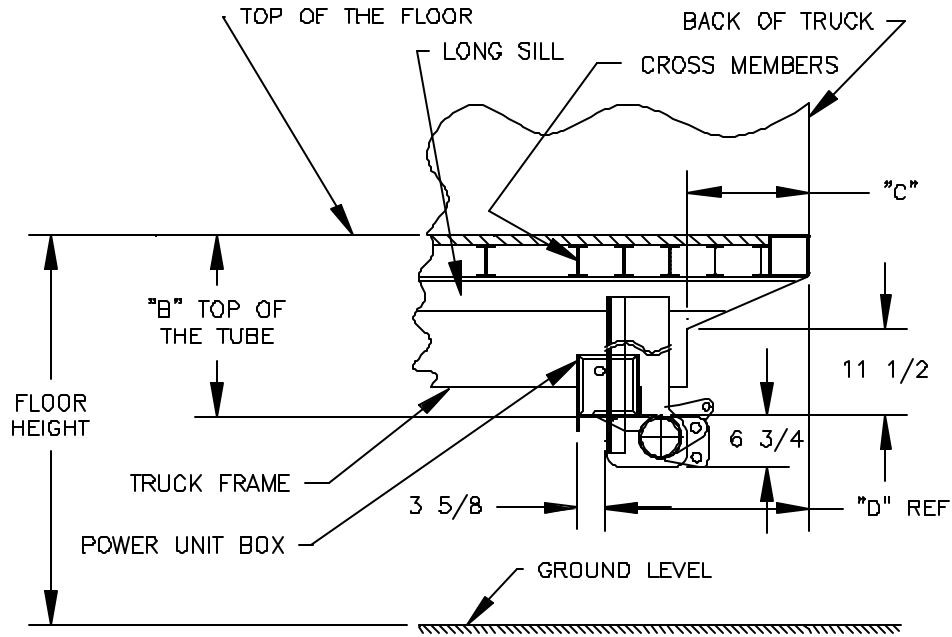

LHS1600 Mounting Dimension Chart

Floor Height	"B"	"C"	"D" REF.	"E" MAX.
42	22-1/2 in	20-1/8 in	29-1/4 in	4-1/4 in
43	22-1/2 in	20-1/8 in	29-1/4 in	4-1/4 in
44	22-1/2 in	20-1/8 in	29-1/4 in	4-1/4 in
45	22-1/2 in	20-1/8 in	29-1/4 in	4-1/4 in
46	23-11/16 in	19 in	28-1/8 in	4-1/4 in
47	23-11/16 in	19 in	28-1/8 in	4-1/4 in
48	23-11/16 in	19 in	28-1/8 in	4-1/4 in
49	23-11/16 in	19 in	28-1/8 in	4-1/4 in
50	23-11/16 in	19 in	28-1/8 in	4-1/4 in
51	23-11/16 in	19 in	28-1/8 in	4-1/4 in
52	24-11/16 in	17-7/8 in	27 in	5 in
53	24-11/16 in	17-7/8 in	27 in	5 in
54	24-11/16 in	17-7/8 in	27 in	5 in
55	25-3/16 in	17-3/8 in	26-1/2 in	5-1/2 in
56	25-11/16 in	16-3/4 in	25-7/8 in	5-1/2 in

NOTE: ADD 3-5/8 IN TO DIM "D" FOR OVER ALL LENGTH

NOTCH REAR SILL

- Notch rear sill
- Check the height of the rear sill
- See chart if the height of the rear sill is larger than the dimension "E" max, the sill must be notched
- See illustration below

Note: After notching the rear sill, add material to reinforce such as 3" x 3" x 3/8" angle or 1" square bar etc. The area cut away must be rebuilt to maintain strength.

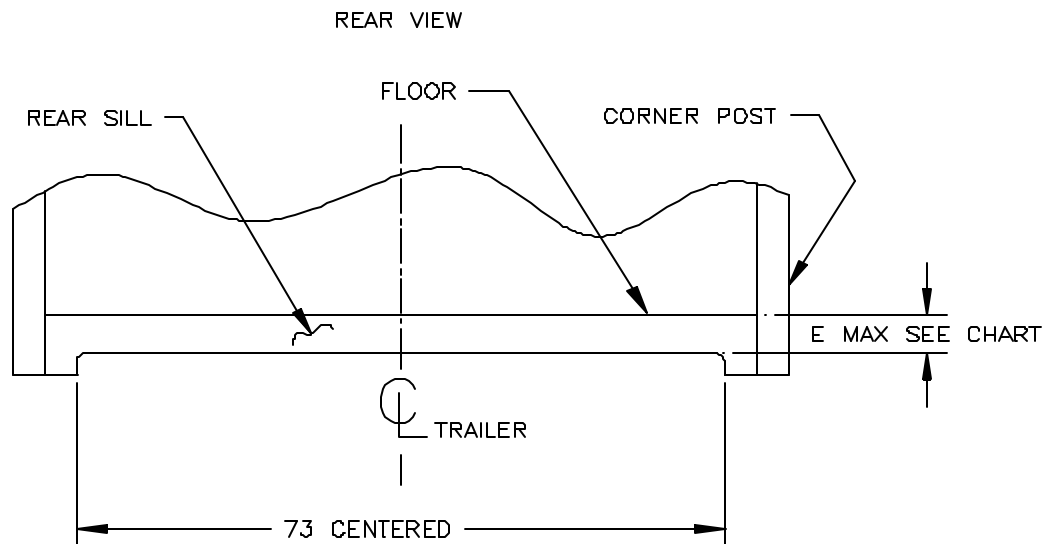

WELD EXTENSION TO REAR SILL

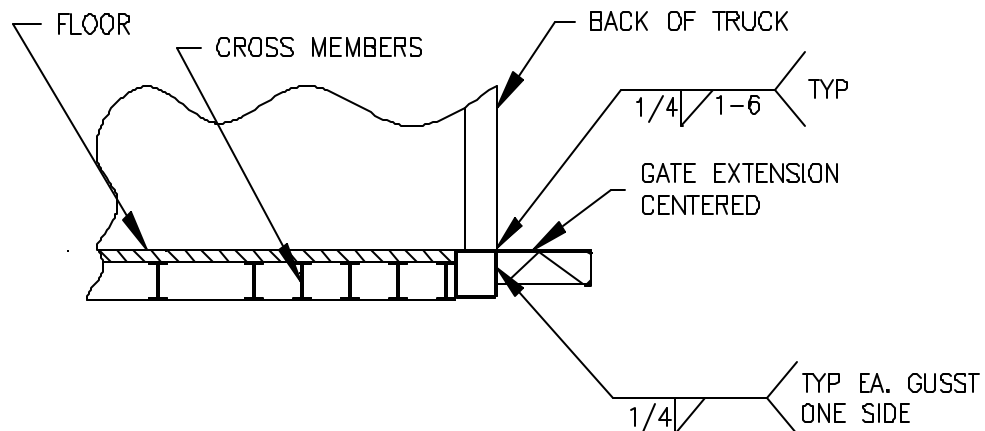

CUT OFF MOUNTING BRACKETS

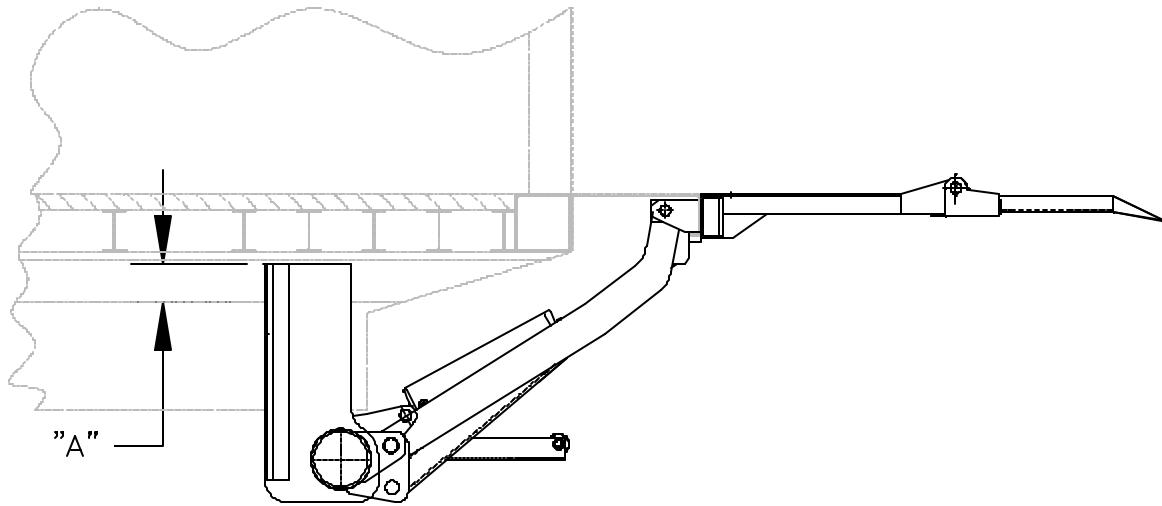

"A" is the dimension that you can trim the mounting brackets to be able to install the gate. Experience tells us that dimension "A" is approximately 4 in. Depending on the dimension of your truck body or chassis, this cut may not be necessary, if the mounting brackets fit well and do not interfere with the body.

MOUNTING GATE ILLUSTRATION

WITH SCRAP CHANNEL, CLAMP
EXTENSION FLUSH TO THE
PLATFORM. FOUR CLAMPS
ARE REQUIRED.

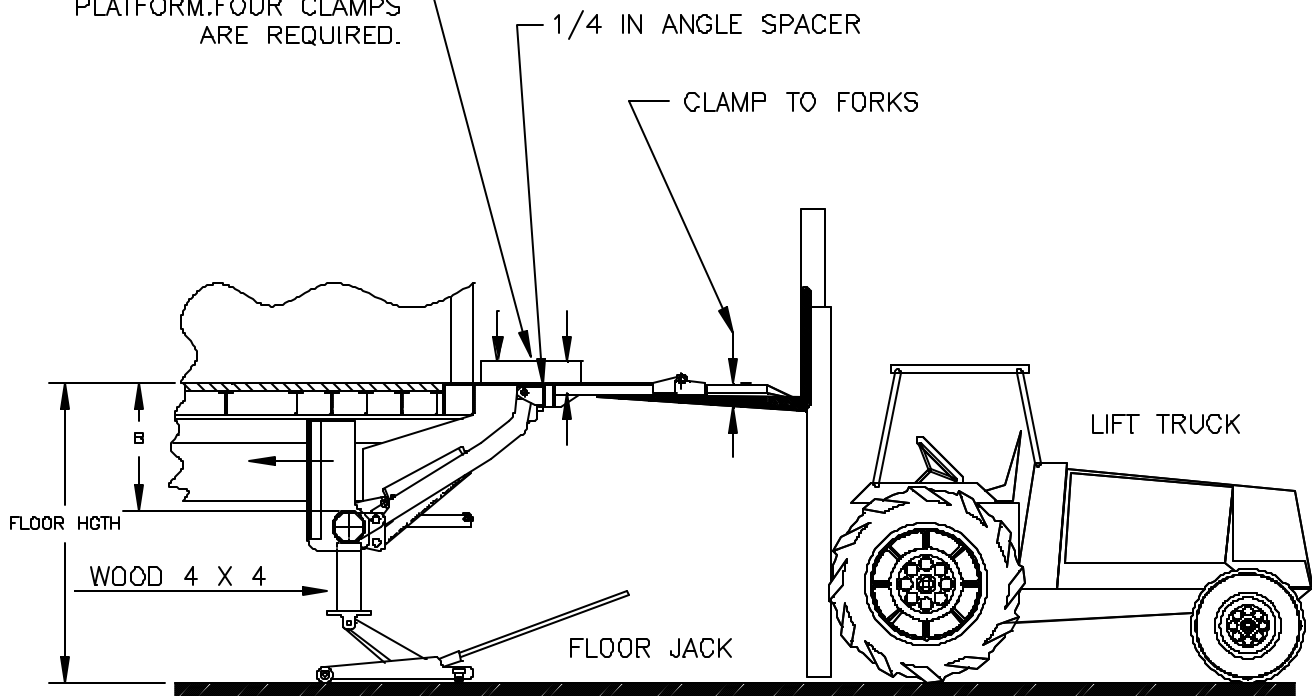

MOUNTING GATE

1. Unfold the secondary platform.
2. Clamp the secondary platform to the forks of the lift truck. Approximately centered (See illustration).
3. There are two angles in the shipping kit, 5" x 3" x 1/4" x 3" lg. Lay these two angles on top of the extension plate to space the platform out 1/4" (See sketch).
4. Pick up the gate assembly. Center on the floor extension, and push against the floor extension and the 1/4 spacers. With two pieces of scrap channel or angle, clamp platform flush with floor. Use four clamps. Clamp channels to extension and platform. Tip of the platform should be 1" higher than the floor extension.
5. With a floor jack and a piece of 4" x 4" wood, swing and raise the main tube until it is at dimension "B" (mounting plates should be outside the truck frame).
6. With a large pipe wrench, rotate the main tube, so that the clevis plate edges are vertical. Then check the rod of the lift cylinder. You should see about 1/2" of polished rod.
7. Now tack weld the main support plates and tube in position, strong enough to hold, so you can run the gate up and down, without a load on it. This is to check the gate functions properly.
8. Unclamp the four clamps holding the platform to the floor extension.
Caution: Do not unclamp the tip of the platform from the forks.
9. Let the lift truck forks down slowly until they will not go any more. (They will stop about 1/2 way down, when they meet resistance from the oil in the lifting cylinder).
10. Install the gate control switch in the desired location and route the wire to the power unit. Slide a piece of supplied shrink tube over the thermal switch wire and connect the black control wire to thermal switch wire using the butt connector pre-installed on the wire. Move the shrink tube to cover the connection and heat to shrink and seal the connection. Connect the white control wire to the lowering valve in the same manner. Attach the green control wire with ring terminal to the large open post of the starter solenoid.
11. For temporary power, use a 12 volt battery. Run a wire from the battery to the starter solenoid, run a ground wire to the truck. The gate will now run. Run gate up and down to check its operation.
12. Finish weld the mounting plates and main tube. CAUTION! Mounting Plate to Lift gate Frame Tube must be welded on BOTH sides. Continuous weld required on outside faces. 8" long weld (half way around) required on inside faces.

13. Weld heavy duty steps (steps are optional) (See 5-13 Illustration "A").
14. Weld shims to stop blocks on platform for proper slope and preload. 16 gauge shims are provided and will give proper slope for average installation (see 5-14 Illustration "B").
15. Weld on stop block for latch, which holds the gate up in the stored position. There should be a 1/16 gap between the block and the latch (see 5-15 Illustration "C").
16. Weld on brackets to protect the hydraulic cylinder (see 5-16 Illustration "D").
17. Run 2 gauge power line from starter on the gate to the truck battery.
Caution: Make sure there is a ground wire from battery to chassis.
18. Take the ground cable located inside of the power unit box and ground to the truck chassis. Seal ground connection at chassis.
19. Paint unit. Apply decals (see decal placement illustration). Lubricate grease fitting at lock pin. Check oil level in power unit tank, when platform is on ground.

5-13 Illustration "A"

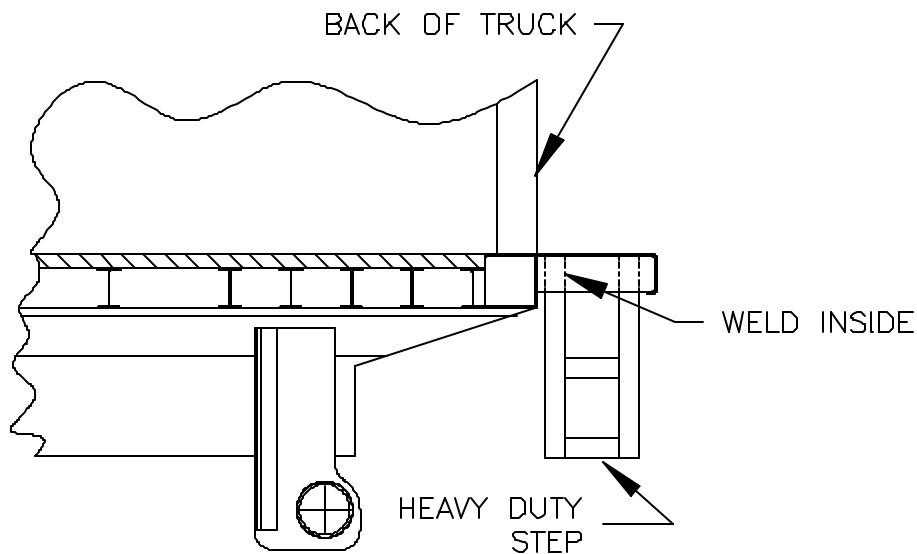

Note: Heavy duty steps are supplied upon request as option number 198.

5-14 Illustration "B"

Weld shims to stop blocks on platform for proper slope and preload. View with platform unfolded, and in the full up position. Platform should slope 1-1/2" on the **LHS** gate and 3/4" on the **LLBS** gate. If a LHS1600 is being installed, platform should slope 1-1/2" when gate is mounted at higher bed heights, and about 1/2" at lower bed heights.

Caution: Ground stop blocks before welding shims

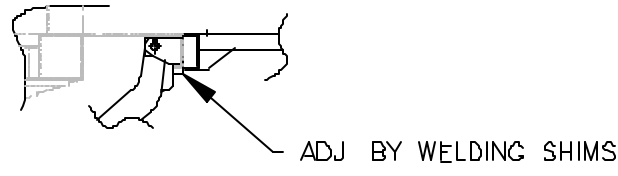

- Weld latch block to tension arm
- Maintain 1/16 gap. This block will hold the gate in the stored position in the event of hydraulic failure.

Caution: Ground arms before welding latch block

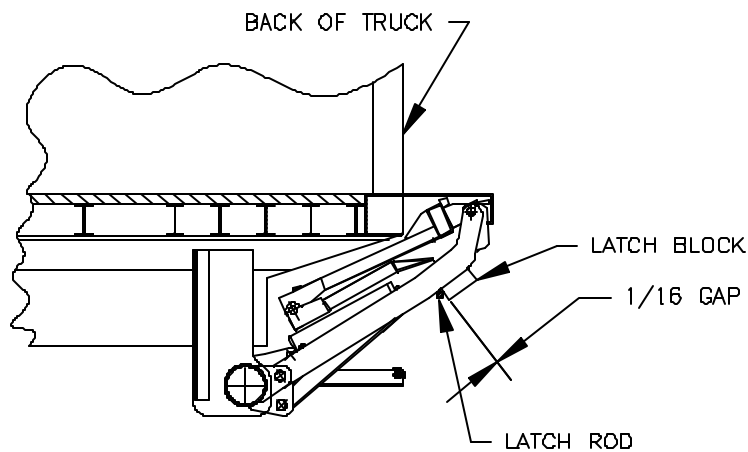

5-16 Illustration "D" Standard Platform

With the platform in position shown (folded horizontal) weld platform brackets (angles supplied) to tension arms, so that platform is resting on brackets approximately 1/2" above cylinder. Weld solid down two sides as shown (1/4 wide fillet weld).

Caution: Ground arms before welding brackets

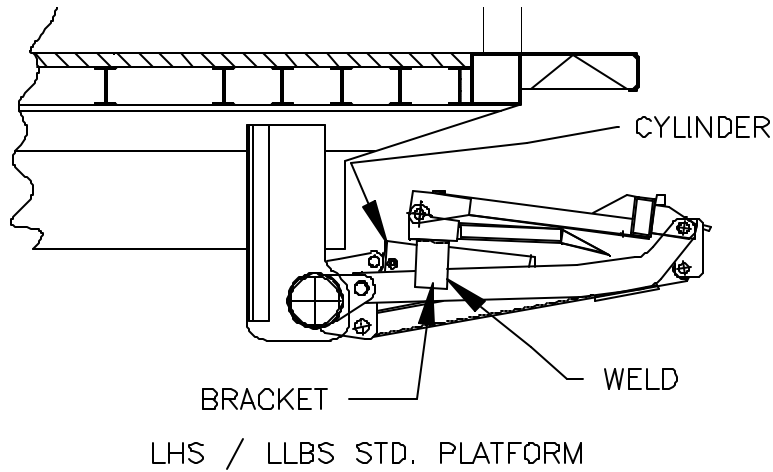

5-17 Illustration “F” Wedge Platform

With the platform in position shown (folded horizontal) weld platform brackets (angles supplied) to tension arms, so that platform is resting on brackets approximately 1/2" above cylinder. Weld solid down two sides as shown (1/4 wide fillet weld).

Caution: Ground arms before welding brackets

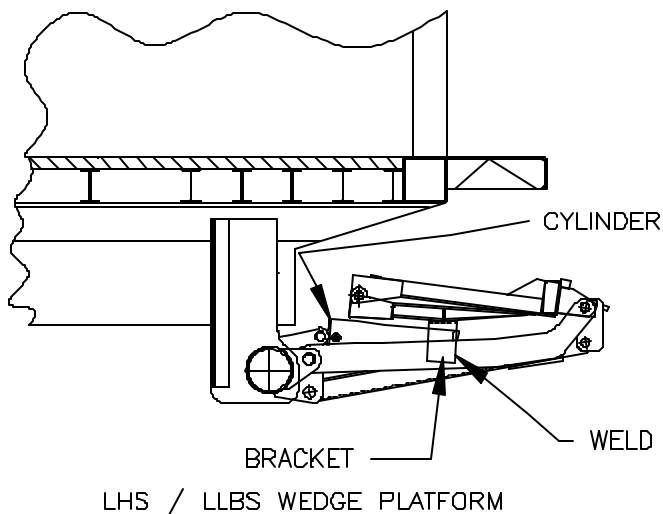

RECOMMENDATIONS

- Use ISO 15 grade hydraulic oil in power unit
- Use multi purpose grease#35 on all grease fittings
- Spray all electrical terminals with protective spray
- Oil all pivots not equipped with grease fittings, using light oil.

TRUBLE SHOOTING CHART LHS & LLBS

PROBLEM	POSSIBLE CAUSE	SOLUTION
The motor is running but the platform will no go up, or reach floor of vehicle or gate will not lift rated load.	<ol style="list-style-type: none"> 1. Insufficient oil in power unit tank 2. Lowering valve is stuck partially or fully open. 3. Power unit relief valve is set too low. 	<ol style="list-style-type: none"> 1. Fill tank 2. Clean or replace 3. Turn screw in all the way, then back off one turn.
The platform will not go up or reach floor level and the motor does not run.	<ol style="list-style-type: none"> 1. Battery is low 2. Power line is loose 3. Poor switch connections 4. Cab switch is turned off 5. Defective starter solenoid 6. Tripped circuit breaker 	<ol style="list-style-type: none"> 1. Recharge battery 2. Check the connections, if loose tighten. Also check for corrosion and clean if necessary 3. See #2 4. Turn switch on 5. Replace part 6. Reset the circuit breaker
Platform will not lower	<ol style="list-style-type: none"> 1. Battery is low 2. Bad ground or electrical connection 3. Lowering valve is bad 	<ol style="list-style-type: none"> 1. Recharge battery 2. Check for corrosion and tighten 3. Check the coil
Platform creeps downward	<ol style="list-style-type: none"> 1. Defective cylinder or piston seal 2. Lowering valve is not seating or partially open 	<ol style="list-style-type: none"> 1. Remove vent line activate to see if there is a continuous flow of oil 2. Clean and inspect
Platform goes down slowly	<ol style="list-style-type: none"> 1. Lowering valve not fully open or clogged 2. Lines are restricted or flow control is clogged 	<ol style="list-style-type: none"> 1. Clean or replace the lowering valve 2. Check for bent or pinched lines. Clean or replace the flow control.
Bent latch pin	<ol style="list-style-type: none"> 1. Latch block welded too far from the latch pin – allowing mechanism to bounce 2. Cylinder leaking 	<ol style="list-style-type: none"> 1. Weld block 1/16 away from pin 2. Remove vent line, activate to see if there is a continuous flow of oil
Hydraulic oil leak from cylinder rod end.	<ol style="list-style-type: none"> 1. Worn seal 2. Cylinder rod pitted 	<ol style="list-style-type: none"> 1. Replace seals in cylinder 2. Replace cylinder

ELECTRIC DIAGRAM

Monarch Power Unit – Thermal Switch in Motor P33991

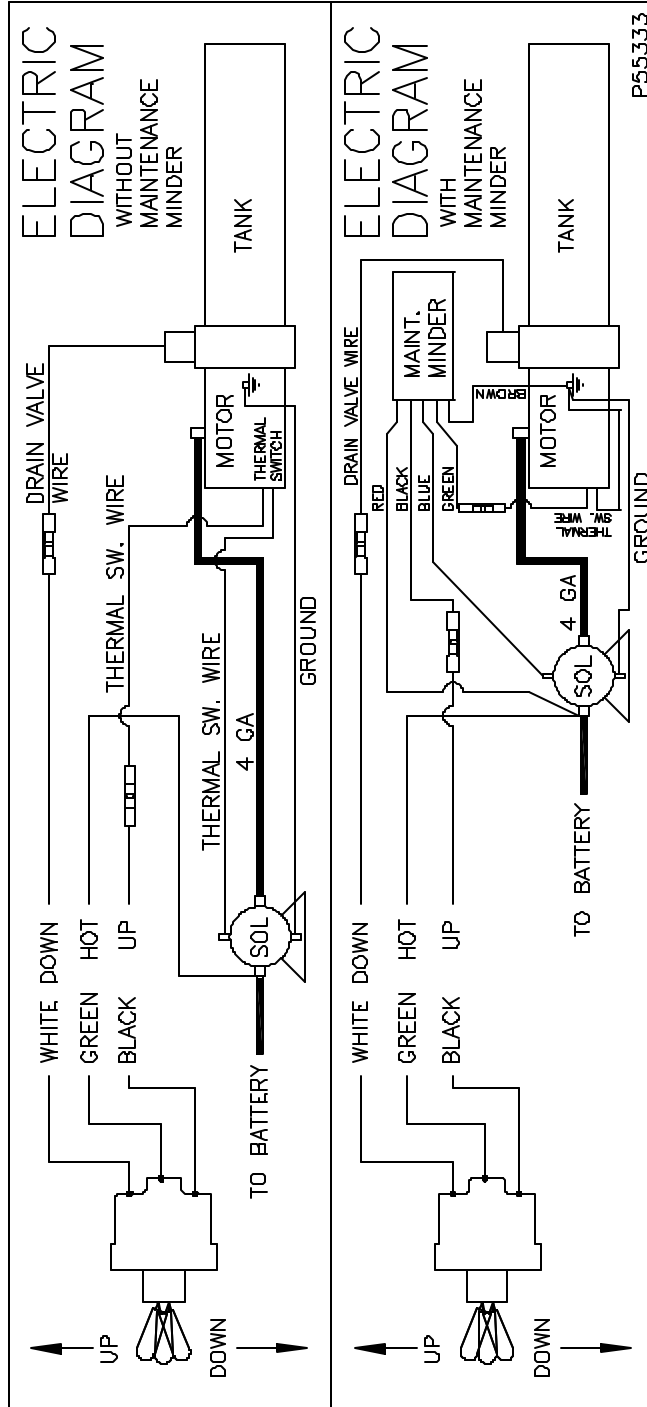

INSTALLING SAFETY DECALS

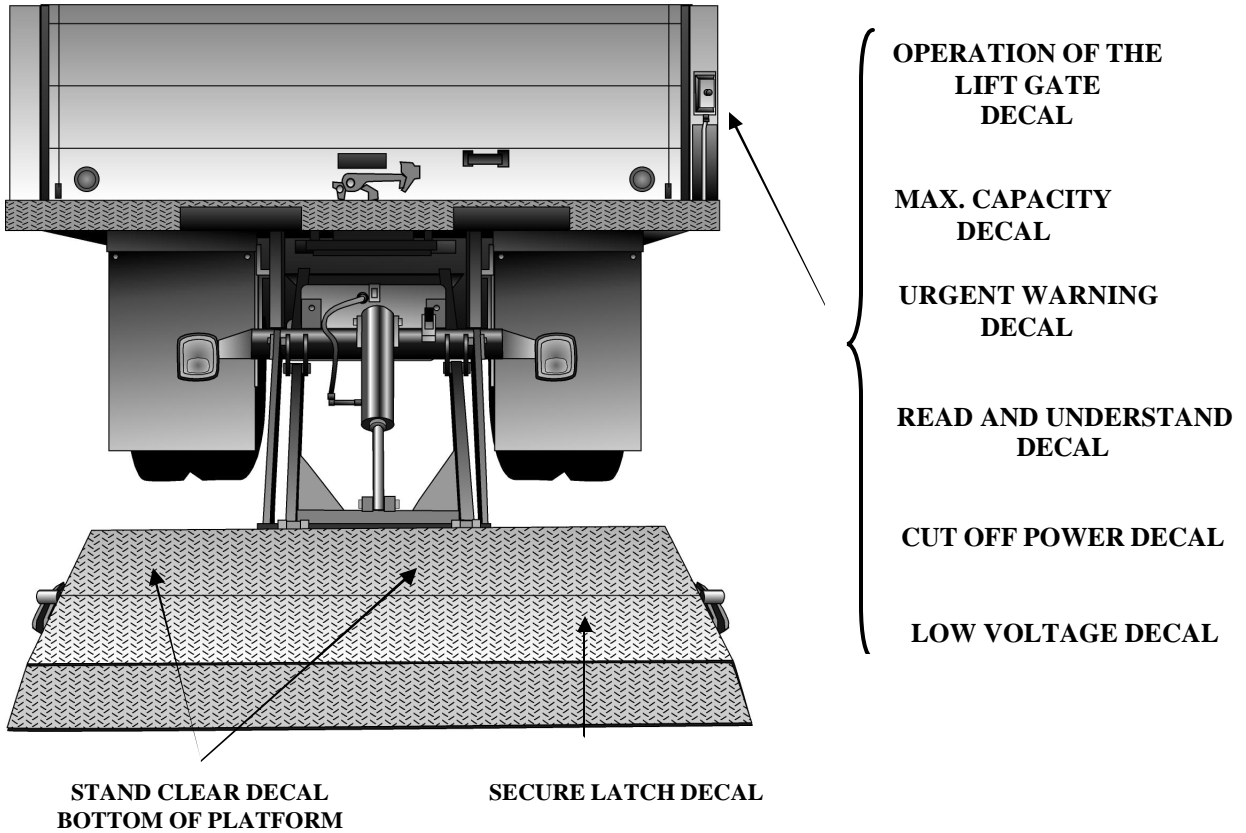

Part #	Qty	Description
P55199	1	Urgent warning decal
P55198	2	Stand clear decal
P55201	1	Power shut off decal
P55202	1	Secure latch decal
P55203	1	Read and understand decal
P55242	1	Low voltage decal
P55307	1	Operation of lift gate
P55200	1	LHS 2500 max. capacity decal
P55200	1	LLBS 2500 max. capacity decal
P55413	1	LHS 1600 max. capacity decal

Note: If gate is a LHS1600, P55413 substitutes P55200

FINAL INSPECTION

CUSTOMER:		
LOCATION:		
VEHICLE#:	LIFT GATE MODEL#:	LIFT GATE SERIAL#:

√ = OK

N = NOT APPLICABLE

	WELDING/ADJUSTMENTS
	Gate is welded secure to vehicle (mounting plates are welded to chassis frame).
	Mounting plates are welded to cross bar tube.
	Extension is welded to vehicle (12-2" or 3" welds across floor and gussets welded inside and out).
	Corners and steps welded to vehicle. Steps are optional.
	Reinforcement braces for corners and steps welded to cross members.
	Battery box welded or bolted secure to cross members.
	All bolts are tightened and secure.
	ICC bumper bar tube installed (optional).
	Lock block welded on tension arm right side (for safety latch rod).
	ELECTRIC'S
	Check that battery holds downs are anchored securely
	Check battery(ies) for proper charge level. PROPER CHARGE LEVEL:
	Check all wiring connections for tightness (batteries, switches, etc.)
	Inspect and check all circuit breakers/fuses.
	Charge line/power line (through cross members with rubber grommets if you prefer)
	Charge line/power line (clamped to bottom of cross members with loom clamps)
	Electric line from gate to power pack (through cross members with rubber grommets if you prefer)
	Electric line from gate to power pack (clamped to bottom of cross members with loom clamps).
	Check operation of toggle switches
	HYDRAULIC/GREASE
	Check reservoir for correct amount of fluid (platform should be open and down when checking)
	Check hydraulic hoses and fittings for leaks
	Check up and down cylinders for leaks.
	Grease safety latch rod.
	OPERATION OF GATE
	Open and close lift gate. Observe for correct operation (platform folds and unfold properly)
	Raise lift gate. (platform is level with floor of vehicle).
	Lowering lift gate (platform brackets and tip of platform rest on the ground).
	ICC bumper does not hit the ground when gate is all the way down with platform on the ground.
	PAINTING AND SAFETY STICKERS
	Repaint where needed
	Check hydraulic cylinder rods for over spray
	Install all safety and operation stickers

